

State of Illinois  
Department Of Transportation

**CONSTRUCTION INSPECTOR'S CHECKLIST  
FOR  
BRIDGE SUPERSTRUCTURES**

While its use is not required, this checklist has been prepared to provide the field inspector a summary of easy-to-read step-by-step requirements relative to the proper construction of all cast-in-place concrete bridge decks ([Section 503](#)). The following questions are based on and referenced to information found in the [Standard and Supplemental Specifications](#), [Highway Standards](#), appropriate sections of the Construction Manual ("CM"), the Manual of Test Procedures for Materials ("MTPM") and the [Project Procedures Guide](#) ("PPG").

**1. PREPARATION PRIOR TO SUPERSTRUCTURE CONSTRUCTION**

a. Office Review (General Items)

- (1) Have you thoroughly reviewed the Contract [Special Provisions, Plans and the Standard and Supplemental Specifications](#)? \_\_\_\_\_
- (2) Have you computed the volume of BS Concrete (see Art.1020.04) and the weight (mass) of Reinforcement Bars for comparison with the quantity shown in the bill of materials? This will help familiarize you with the plans, find plan errors prior to starting construction, and satisfy part of your documentation requirements. (Note: This is not a documentation requirement if Form [BC 981](#), Agreement On Accuracy of Plan Quantities is jointly signed.) \_\_\_\_\_
- (3) Have you reviewed the [Project Procedure Guide](#) ("PPG") for minimum testing requirements? \_\_\_\_\_
- (4) If this contract contains the Recurring Special Provision for Quality Control/Quality Assurance (QC/QA) of Concrete Mixtures, have you reviewed the QC/QA special provision and discussed its requirements with the district Materials office? In addition, has the district Materials office approved the contractor's Quality Control Plan? \_\_\_\_\_
- (5) Have you determined what material must be inspected prior to incorporation into the work and what material certifications are required? (See PPG Attachment 3) \_\_\_\_\_
- (6) Have you reviewed the appropriate sections of the Construction Manual (CM): [Section 500](#), the CM [Documentation Section](#), the CM [Forms Section](#), Construction Memorandum Nos. [39](#), [45](#), [64](#), [72](#), [73](#), [74](#) and [78](#), and the [Project Procedures Guide](#) (PPG)? \_\_\_\_\_

- (7) If this contract contains the Structural Assessment Reports special provision (SARs), have the submittal requirements been fulfilled? (Note per the SAR special provision, separate portions of work may be covered by separate SARs. Thus there may be various SAR submittals at various times.) \_\_\_\_\_
- (8) Have approved final shop drawings been received and are they available for reference when products are delivered to the jobsite? \_\_\_\_\_
- (9) If required by Materials, has the Contractor supplied additional elastomeric bearing assemblies for testing? (See Art. 1083.04, Art. 521.09) \_\_\_\_\_
- b. Office Review (Precast Prestressed Concrete items – Prior to jobsite Delivery)
  - (1) Have you reviewed the [Manual for Fabrication of Precast Prestressed Concrete Products](#)? In particular see Section 1.2 and Appendix A for maximum allowable dimensional tolerances, Section 3.5 for allowable damage and repairs, and Appendix A for procedures to remedy unacceptable products. The Manual for Fabrication of Precast Prestressed Concrete Products can be found at <http://www.dot.il.gov/materials/guidesmanuals.html> \_\_\_\_\_
  - (2) Have you verified with the District Materials Engineer if any product was declared unacceptable and if a remedy for the unacceptable product has been approved? If a remedy for any product declared unacceptable has been approved, obtain a copy of the “Notice of Unacceptable Product at Plant or Jobsite” form ([BMPR PS02](#)) and the remedy approval notification for the project file. \_\_\_\_\_
  - (3) Have you verified with the District Materials Engineer if the fabricator has developed an alternate transportation loading configuration (in lieu of the configuration specified in Std. Spec. Art. 504.06 (c)? (Note, Art. 504.06 (c) may not apply in all cases because of the length and depth of the beams, the transportation route to deliver the beams, or other circumstances.) If the fabricator has developed an alternate transportation loading configuration, its design should be sealed by a licensed Illinois structural engineer and approved by the Bureau of Bridges and Structures. The approved transportation loading configuration is to be used for checking the location of bolsters or other supports. \_\_\_\_\_
- c. Field Review
  - (1) Are you checking the bearing seat elevations before and after each abutment or pier pour? Errors caught at this stage can

often be corrected by grinding, shimming or adjusting elevations. \_\_\_\_\_

(2) Are you laying out bearing lines on top of abutments and piers for beam erection and checking span lengths between abutments and piers? \_\_\_\_\_

(3) Are the bearing areas on supporting masonry being finished within allowable tolerances? Improperly finished, deformed or irregular bearing areas shall be ground smooth, filled or otherwise corrected to within allowable tolerances to provide even bearing on the seats. (See Art. 503.15(c), 505.08(a), 505.08(f) and CM Division 500) \_\_\_\_\_

(4) Are you inspecting the material as it is delivered to the jobsite for evidence of inspection (See PPG Attachment 3), that the material has not been damaged due to mishandling subsequent to inspection and that it is being properly stored? \_\_\_\_\_

**2. BEAM ERECTION**

a. Pre-Erection (General Items)

(1) If this contract contains the Structural Assessment Reports special provision (SARs), has the erection SAR been approved? \_\_\_\_\_

(2) Have you had a pre-erection meeting with the Contractor to discuss the erection plan, bolting requirements, jobsite samples, job site testing and test equipment, etc. as applicable? (This is not a contract requirement, but is highly recommended.) \_\_\_\_\_

(3) Do you have proper evidence of inspection for all materials to be used? (See PPG Attachment 3) \_\_\_\_\_

b. Pre-Erection (Structural Steel items)

(1) Before starting erection, has the Contractor submitted an erection plan detailing the proposed methods of erection and the amount, location(s) and type(s) of equipment to be used? Has the plan been approved by the Engineer? (See Art. 505.08(e)) (Note, if the contract contains the SARs special provision, the special provision holds over Art. 505.08(e) See Art. 105.05) \_\_\_\_\_

(2) If falsework is needed for the erection process, has the Contractor submitted erection falsework plans for review, or has the submittal been waived by the Engineer? (See Art. 505.08(d)) (Note, if the contract contains the SARs special provision, the special provision holds over Art. 505.08(d) See Art. 105.05) \_\_\_\_\_

c. Pre-Erection (Precast Prestressed Concrete items – Arrival at jobsite before unloading)

(1) Does the product have an ILL OK stamp? If the product doesn't have the ILL OK stamp, issue a notice of unacceptable product (BMPR PS02) to the contractor and contact the District Materials Engineer. (See Art. 106.02 for additional guidance regarding unacceptable materials and Section 3.6.3 of the Manual for Fabrication of Precast Prestressed Concrete Products for more information on the ILL OK stamp.) \_\_\_\_\_

(2) Are the bolsters or other supports at the correct location, per Std. Spec. Art. 504.06 (c) or an approved alternate (project specific) loading configuration, for transporting the product? If bolsters or supports are located incorrectly, subsequent inspection will be required to verify that the product did not incur crack damage. It is recommended the product be returned to the Producer for this inspection. If it is not feasible to return the product to the Producer, access to the entire beam is required for inspection. Note, it may not be feasible (or possible) to perform this inspection after the product is placed in its final location. Thus, an immediate inspection will likely be required. This immediate inspection may delay the contractors operation. \_\_\_\_\_

3. Were wood blocks or other suitable material, per Std. Spec. Art. 504.06 (c), placed under the tie chains (by the supplier) to prevent chipping the concrete during transport? If shipping damage is identified, issue a notice of unacceptable product (BMPR PS02) to the contractor. \_\_\_\_\_

d. Structural Fasteners

(1) Have you reviewed the Inspectors Checklist for Structural Steel Bolting and Construction Manual Section 500? \_\_\_\_\_

(2) Have the high strength bolts, nuts and washers been fabricated domestically from domestically produced steel (See Art. 106.01)? \_\_\_\_\_

(3) Does the shipment of fastener assemblies have the required evidence of materials inspection? (See PPG Attachment 3)

If bolting hardware has not have the required evidence of materials inspection, are you obtaining three bolts of each size and length and three nuts and washers of each size, per lot, and submitting them to the BMPR for testing? (See PPG Attachment 3) \_\_\_\_\_

(4) Has the Contractor given you the Mill Test Report(s), Manufacturer Certified Test Report(s), and (if applicable) the Distributor Certified Test Report(s) for each Rotational

- Capacity (RC) lot delivered to the job site? (See Art. 505.04(f)(3)f.2) \_\_\_\_\_
- (5) Has the Contractor supplied a calibration device capable of indicating bolt tension to perform the Rotation Capacity (RC) tests and field verification tests? (See Art. 505.04(f)(2) and 505.04(f)(3)g.1) \_\_\_\_\_
- (6) Has the Contractor supplied a calibrate dial inspection torque wrench (See Art. 505.04(f)(2) and 505.04(f)(3)g.1) \_\_\_\_\_
- (7) Have you performed the field RC tests on two fastener assemblies (except Lock-pin and Collar type fasteners) of each RC Lot delivered to the job site? (See Art. 505.04(f)(3)g.1, CM Sec. 500 – Procedure for Performing Rotational Capacity Test) \_\_\_\_\_
- (8) Has the Contractor supplied a representative sample of not less than 3 fasteners of each diameter, length and grade to be checked in the supplied calibration device at the job site? If any fastener fails to meet the required minimum tension, the lot it was taken from will be rejected. (See Art. 505.04(f)(2), CM Sec. 500 – Procedure for Installation and Tightening of High Strength Fasteners) \_\_\_\_\_
- (9) Has each bolting crew demonstrated understanding of the procedural requirements for the fastener system selected by the Contractor? (See Art. 505.04(f)(2), and CM Div. 500) \_\_\_\_\_
- (10) Are bolts, nuts, and washers from each Rotational Capacity (RC) lot being shipped in the same container? (Note, when there is only one production lot number for each size of nut and washer, the nuts and washers may be shipped in separate containers.) (See Art. 505.04(f)(3)f.1) \_\_\_\_\_
- (11) Is each container permanently marked with the RC lot number, both on the container and on the lid? (See Art. 505.04(f)f.1) \_\_\_\_\_
- e. Structural Steel
  - (1) Are inaccessible areas being painted prior to erection (bottom and top of bearings, back of beams and diaphragms, top flange in non-shear stud areas, etc.)? (See Art. 506.04(f), 506.04(g), 506.05 and Special Provisions) \_\_\_\_\_
  - (2) Are beams and diaphragms being handled properly to keep damage to the prime coat to a minimum? (See Art. 505.08(c)) \_\_\_\_\_
  - (3) Once bolting hardware is opened is it being stored out of the weather or in sealed watertight containers or bags? \_\_\_\_\_

- (4) Are the galvanized nuts lubricated with a tinted dry lubricant and plain bolts, nuts and washers lightly lubricated prior to installation? If not is an acceptable lubricant being applied before tightening? (See Art. 505.04(f)(3)g.2) \_\_\_\_\_
  
- (5) During erection of all structural steel members on continuous spans, are the splices being filled with a minimum of 25% bolts and 25% drift pins? No splice connection shall be tightened (snug tightened or final tightened) until the entire continuous length is in place on the substructure to permit the alignment of the beams to be at the plan profile and grade.. (See Art.505.08(h) & CM Div. 500) \_\_\_\_\_
  
- (6) Is the Contractor using the following procedure to complete the installation of the fasteners at each splice and field connection:
  - (a) Is the Contractor removing all drift pins and filling all holes in the splice with 100% finger-tight bolts? (See Art. 505.08(h)) \_\_\_\_\_
  - (b) Do all high-strength bolts have a hardened washer under the element (nut or bolt head) turned in tightening? (See Art. 505.04(f)(2)) \_\_\_\_\_
  - (c) Are the fasteners in all holes of the connection initially brought to a snug tight condition, progressing systematically from the most rigid part of the connection to the free edges in a manner minimizing relaxation of the previously tightened fasteners? (See Art. 505.04(f)(2)) \_\_\_\_\_
  - (d) If using the Turn-of-Nut Method, is the contractor performing a minimum of two cycles of systematic snug tightening for connections with 25 mm (1 in.) and thicker plates to minimize relaxation of previously tightened fasteners prior to final tightening? (See Art. 505.04(f)(2)d.1) \_\_\_\_\_
  - (e) After all fasteners in the connection are snug tight, is the Contractor fully tightening the fasteners progressing systematically from the center most rigid part of the connection to its free edges? (See Art. 505.04(f)(2)) \_\_\_\_\_
  
- (7) Have you verified that all fasteners have been installed to the minimum required tension? (See Article 505.04(f)(2), CM Div. 500 – General Procedure for Inspection of High Strength Fasteners Installation, and Construction Inspector’s Checklist for High Strength Bolting) \_\_\_\_\_
  
- (8) Is the Contractor aware that no field welding or flame cutting will be allowed on beams or girders without permission of the Engineer? (See Art. 505.08(n), and bridge plan general notes) \_\_\_\_\_

f. Precast, Prestressed Concrete – Unloading and Handling

- (1) Is the Contractor fully engaging all the lifting loops as shown on the shop drawings? Never allow the contractor to lift a product without fully engaging all the lifting loops as shown on the shop drawings. Be advised that extra lifting loops may be used by the Producer at the plant because of their handling equipment. These loops are supposed to be removed at the plant, but sometimes they are not. Thus, it is important to review the shop drawings. (See Art. 504.06(d) and CM Div. 500)
- (2) Is the contractor utilizing an adequate spreader beam and slings to prevent the development of detrimental horizontal forces in the product? Note, the minimum sling angle should be shown on PPC beam plan sheet(s). (See Art. 504.06(d) and CM Div. 500)

g. Precast, Prestressed Concrete – After Placement at the jobsite

- (1) Have you Examined beams for excessive sweep (i.e. horizontal curvature)? This should be performed during or as soon as practicable after placement. Be advised that as the sun shines on the beams it will cause temperature differentials that may cause the beams to temporarily warp. Thus, it may be necessary to examine the beams for sweep early in the morning when temperature differentials are minimized. (See dimensional tolerance information provided in Section 1.2.4 and Appendix A of the Manual for Fabrication of Precast Prestressed Concrete Products. In rare instances, beams may be in tolerance for sweep but still cannot be placed properly. In this situation it is important to contact the Bureau of Bridges and Structures.)
- (2) Have you examined beams for unusual camber (i.e. vertical curvature)? Unusual camber includes no camber, negative camber, excessive differential camber with adjacent deck beams and excessive camber contributing to thin wearing surfaces on deck beams or negative fillets on I – Beams/Bulb T – Beams. (See Art. 504.06(d), CM Div. 500 and Manual for Fabrication of Precast Prestressed Concrete Products – Appendix A – “Procedure to remedy an unacceptable prestressed product at the jobsite”)
- (3) Have you examined the product for cracks, per Section 3.5 of the [Manual for Fabrication of Precast Prestressed Concrete Products](#), using a crack comparator and tape measure? (Do not drill, or allow drilling, into PPC products without prior consultation with the Bureau of Bridges and Structures.) As an aid to the inspection, it is suggested to spray the concrete surface with water to help locate cracks. If cracks not

exceeding the Department's limits are located, verify if repairs per Section 3.5.6 of the [Manual for Fabrication of Precast Prestressed Concrete Products](#) were performed. This may be seen visually or you can contact the Department's QA plant inspector. If cracks exceeding the Department's limits are located, issue a notice of unacceptable product ([BMPR PS02](#)) to the contractor.

- (4) Have you verified no chips, spalls, or other damage occurred to the concrete during handling at the jobsite? It is not uncommon for beam torsion (twisting) to occur during handling which may cause damage or spalling of concrete. If handling damage is identified, issue a notice of unacceptable product ([BMPR PS02](#)) to the contractor.

Note. When a notice of unacceptable product ([BMPR PS02](#)) is issued, follow the "procedure to remedy an unacceptable prestressed product at the jobsite" outlined in Appendix A of the [Manual for Fabrication of Precast Prestressed Concrete Products](#).

h. Bearings

- (1) Are bearings being handled properly to prevent damage? This is particularly important for Type II bearings, since the stainless steel and Teflon sliding surfaces are very easily damaged.
- (2) Are all bearing sliding surfaces clean before installation and kept clean after installation?
- (3) If Type II Elastomeric, Type III Elastomeric, or High Load Multi-Rotational bearings are utilized are they being adjusted to center vertically over bearing and base plates at 10 °C (50 ° F)? (See bridge plan detail)
- (4) If Type II Elastomeric, Type III Elastomeric, or High Load Multi-Rotational bearings are utilized are their anchor bolt holes being drilled after bearings are in place? (See bridge plan note and Art. 521.06)
- (5) After anchor bolts are installed, have you check the upper ends of the bolts to verify proper embedment? Anchor bolt lengths should leave the exposed end projecting between 12 mm (1/2 in.) and 50 mm (2 in.) above the top of the nut. (See Art. 521.06)
- (6) Have all bearing side retainers been secured in place prior to forming the bridge deck? (See Art. 505.08(f))

**3. PRE-DECKING**

a. Fillets

- (1) Are you marking each beam at the fillet intervals as shown in the plans and preparing a field book for elevation shots? \_\_\_\_\_
- ((2) Are fillet elevations being shot after all structural fasteners in a continuous steel span are final tightened? \_\_\_\_\_
- (3) Are fillet elevations being shot before forms have been placed? The weight of the forming wood is not taken into account by the deflection diagram. \_\_\_\_\_
- (4) Are you consulting with the supervising field engineer if there are negative or excessive positive fillets? The deck grades may require adjustment. Fillets in excess of 6 in. (150 mm) may require additional reinforcement – contact the Bureau of Bridges & Structures if excessive fillets have not already been addressed in the plans. Without reinforcement, shear studs must extend at least 2 in. (50 mm) into the deck. \_\_\_\_\_
- (5) Are you marking fillets in 3 mm (1/8 inch) increments at each location? \_\_\_\_\_

b. Inspection of Delivered Epoxy Coated Reinforcement Bars

- (1) Are all the systems used for handling padded at the contact areas? (Art. 508.03 and Reinforcement Bars – Storage and Protection Special Provision) \_\_\_\_\_
- (2) Are bars being protected from mechanical injury and deterioration by exposure? (See 508.03 and Reinforcement Bars – Storage and Protection Special Provision) \_\_\_\_\_
- (3) Is storage on wooden or padded steel cribbing? (Art. 508.03 and Reinforcement Bars – Storage and Protection Special Provision) \_\_\_\_\_
- (4) Are rebars from a certified plant? Compare the identification marking on bars with the latest list of certified plants, from BMPR. Reject all rebars from non-certified plants. <http://www.dot.il.gov/materials/rebardowelproducers.pdf> \_\_\_\_\_
- (5) Is the epoxy coating applicator on the approved list of certified epoxy coating plants? (See Reinforcement Bars Special Provision) <http://www.dot.il.gov/materials/epoxycoatingproducers.pdf> \_\_\_\_\_
- (6) Do rebars conform to the plan shape and dimensions? \_\_\_\_\_
- (7) Although rebars will be in bundles, are you making a preliminary check for damaged epoxy coating? Total damage \_\_\_\_\_

greater than 2 percent of the bar surface in any 1 ft. (300 mm) of length of the bar or greater than 5 percent of the bar surface area covered with patching material shall be rejected. Scars greater than 1/16 sq. in. (40 sq. mm) can be repaired after placed in the deck mat. (See Art. 508.05)

**4. DECKING FOR CONCRETE PLACEMENT**

a. Screed Rail Installation and No Weld Areas

- (1) Are you prohibiting the welding to or drilling or cutting holes in beams/girders? (See Art. 503.06 and bridge plan general note) \_\_\_\_\_
- (2) Is the Contractor obtaining permission before making any field welding not specified in the contract documents? Contact the Bureau of Bridge & Structures. (See bridge plan general note – "No welding allowed anywhere", and Art. 505.08(n)) \_\_\_\_\_

b. Forms

- (1) Are forms set to correct fillet height? \_\_\_\_\_
- (2) Are form dimensions correct? \_\_\_\_\_
- (3) Are forms clean, braced, tight and sufficiently rigid to prevent distortion? Are you rejecting any forms that are not acceptable for reuse? (Art. 503.06) \_\_\_\_\_
- (4) Are forms (adjacent to surfaces that will be exposed to view) being treated with form oil prior to rebar placement? (See Art. 503.06) \_\_\_\_\_
- (5) Is all forming hardware that is to be incorporated into the deck galvanized or epoxy coated? (Art. 503.06(b)) \_\_\_\_\_
- (6) Are all joints tight to prevent concrete leakage onto beams or girders? (See Art. 503.07) \_\_\_\_\_

c. Cantilever Forming Brackets

If the Contractor uses cantilever forming brackets on exterior beams or girders, are the following procedures being complied with to prevent beam rotation and a possible thin deck (Art. 503.06(b))? \_\_\_\_\_

- (1) Is the resulting force of the leg brace bearing on the web within 6 inches (150 mm) from the bottom flange of the beam or girder? (Art. 503.06(b)(1)) \_\_\_\_\_
- (2) Is the top of the exterior steel beams or girders tied together with a minimum No. 4 (No. 13) epoxy coated reinforcement, or equivalent at no greater than 4 ft. (1.2 m) centers if the

finishing machine rails are on the outside of the watertable, or 8 ft. (2.4 m) centers if the finishing machine rails are on the top flange of the exterior beams? On stage construction, where cantilever brackets are used on only one exterior line of beams or girders, this line shall be tied to the opposite exterior line. Cross frames on steel girders which do not have a top strut shall not be considered a tie. (See Art. 503.06(b)(2)) \_\_\_\_\_

(3) If steel beams 27 inches or shallower are utilized are you following special details outlined on the bridge plan base sheet SB-1. Note, the finishing machine rail must be on the beam and the tie bars and blocking are to be at 4 ft. (1.2 m) centers. \_\_\_\_\_

(4) Are the tie bars being placed at no greater than 8 ft. (2.4 m) centers on precast, prestressed concrete (PPC) I-beams and bulb-Tees regardless of where the finishing machine rails are placed? On stage construction, where cantilever brackets are used on only one exterior line of beams or girders, this line shall be tied to the opposite exterior line. (See Art. 503.06(b)(2)) \_\_\_\_\_

(5) Are tie bars being placed parallel to the transverse reinforcement? (See Supp. Spec. partial revision to Art. 503.06) \_\_\_\_\_

(6) Are tie bars being placed no lower than the bottom transverse reinforcement or no higher than the top transverse reinforcement? Special brackets and/or reworking existing brackets may be required to maintain proper placement. (See Supp. Spec. partial revision to Art. 503.06) \_\_\_\_\_

(7) Is each tie bar furnished with an approved tie bar stabilizing system consisting of adjustable end clips, lag studs, and turnbuckles? Are the end clips and lag studs sufficiently rigid so as not to deflect during the deck pour? (See Supp. Spec. partial revision to Art. 503.06) \_\_\_\_\_

(8) Are you prohibiting welding to the structural steel, stud shear connectors, or reinforcement bars protruding from PPC beams for the installation of the tie bar stabilizing system? (See Supp. Spec. partial revision to Art. 503.06) \_\_\_\_\_

(9) After installation, are the tie bars tensioned with turnbuckles until the bars do not vary from a straight line from center of end clip to center of opposite end clip? For decks with cross slopes, it may be necessary to anchor the ties on the exterior girders and on the girders adjacent to the cross slope crown. (See Art. 503.06(b)(2) and Supp Spec. partial revision to Art. 503.06) \_\_\_\_\_

(10) Are hardwood 4 inch x 4 inch (100 mm x 100 mm) blocks or material of an equivalent strength being wedged between

webs of exterior and first interior beams within 6 inches (150 mm) of the bottom flanges at each location where the top of the beams are tied together? (Art. 503.06 (b)(3)) \_\_\_\_\_

d. Shear Studs

(1) As soon as the fillet heights are determined are you providing the Contractor with a list of the number and length of studs necessary to provide the required minimum 2 inch (50 mm) deck embedment? (See bridge plan detail) \_\_\_\_\_

(2) Are you checking the Contractor's layout of the stud locations versus plan locations? \_\_\_\_\_

(3) Are you prohibiting stud welding when the flange surface is wet or the base metal temperature is below 0 °F (-17 °C) (without preheating the metal)? (See Art. 505.08(m)(2)) \_\_\_\_\_

(4) Is each stud location being prepared by grinding, lightly, parallel to the beams longitudinal axis to remove mill scale and heavy rust? (See Art. 505.08(m)(2)) \_\_\_\_\_

(5) Is the operator making the required 45° bend test? (See Art. 505.08(m)(3)) \_\_\_\_\_

(6) Are you making a 45° bend test with a heavy hammer on about 1% of the studs per beam? (See Art. 505.08(m)(3)) \_\_\_\_\_

(7) Are you testing suspect studs by bending the stud 15° opposite the deficiency and bending it back vertically then rejecting studs showing visual stress? (Art. 505.08(m)(3)) (It is recommended you "ping" each stud with the hammer.) \_\_\_\_\_

(8) Are you requiring defective studs to be removed and replaced with a new stud in the same location as the defective stud, after properly grinding the vacated area to a smooth flush condition or filling pullout of metal in the vacated area with weld metal using the shielded-metal arch process and low-hydrogen electrodes. (See Art. 505.08(m)(3)) \_\_\_\_\_

NOTE: This method of repairing defective studs is appropriate only in positive moment areas. For defective studs near piers, contact the Bureau of Bridges and Structures.

e. Reinforcement Bar Placement

(1) Are all reinforcement bars tied securely in place? Are epoxy coated rebars being tied with plastic or epoxy coated tie wire? (Floating or sticking rebars into wet concrete shall not be allowed.) (See Art. 508.05) \_\_\_\_\_

- (2) Are all rebar intersections being tied? Alternate intersection tying will be allowed when spacing is less than 1 ft. (300 mm) in each direction. (See Art. 508.05) \_\_\_\_\_
- (3) When epoxy coated rebars are specified to be cut in the field, are they being sawed or sheared and the cut ends painted with epoxy? (Flame cutting is not permitted.) \_\_\_\_\_
- Note: "spray can" epoxy repair will not satisfy ASTM D 3963<sub>[m1]</sub> (See Art. 508.04)
- (4) Are epoxy coated rebars handled properly to prevent damage to the rebar coating? (Use rope slings, no dragging or dropping permitted.) (Art. 508.03) \_\_\_\_\_
- (5) Are all rebar laps of the specified length (plans will show splice length) and contact spliced? (See Art. 508.06) \_\_\_\_\_
- (6) Are the reinforcement bar chairs epoxy coated and at the required spacing? (See Art. 508.05) \_\_\_\_\_  
 Bottom bars - Continuous chairs at 3 ft.-3 inches (1m ) maximum spacing \_\_\_\_\_  
 Top bars - Continuous chairs at 3 ft. (900 mm) maximum spacing, or individual chairs at 2 ft. (600 mm) x 3 ft. (900 mm) maximum spacing. \_\_\_\_\_
- (7) Are the rebars in the tops of slabs being securely held in place by plastic or epoxy coated No. 9 (3.8 mm) wire ties, or other devices fastened to the structural steel, falsework, or other structural component? (Every 25 ft. (7.6 m) longitudinally and 15 ft. (4.5 m) transversely) (See Art. 508.05) \_\_\_\_\_
- (8) After epoxy coated rebars are in place, are you inspecting the rebars for damage to the coating and requiring the Contractor to repair all scars greater than 1/4 by 1/4 in. (6 x 6 mm)? (See Art. 508.05) \_\_\_\_\_
- (9) Are rebars being rejected that have either a total damage greater than 2% of the bar surface in each 1 ft. (300 mm) length of bar or greater than 5 percent of the bar surface area covered with patching material? (See Art. 508.05) \_\_\_\_\_
- (10) For longitudinal or transverse joints in the deck with rebars protruding through the pour, has the Contractor constructed a platform outside the joint, above the protruding bars, and supported on the lower slab form? Personnel will not be permitted to stand or walk on the projecting reinforcement bars until the concrete has hardened. (See Art. 503.09) \_\_\_\_\_

f. Screed Rails

- (1) Are you checking the screed rail elevation from the fillet points and checking the rail for a smooth curve through all the grade points by eyeballing? \_\_\_\_\_

g. Longitudinal Bonded Construction Joints

- (1) Are the longitudinal bonded construction joint forms being set at the required location? With the approval of the Engineer, the Contractor may be allowed to pour the deck out-to-out. (See Art. 503.09) \_\_\_\_\_

- (2) Is the grade of the longitudinal construction joint form, or the temporary screed bars, being set with an instrument and check measured against the designed deck slab thickness? \_\_\_\_\_

h. Deck Drainage Openings

- (1) Are required drainage openings in the proposed deck at the proper location, elevation and positioned so as to prevent the discharge of drainage water against any portion of the structure, or directly onto any railroad, highway, or unprotected earth below? Make sure the floor drains and scuppers are not unintentionally placed partially under the parapet location. Note that the edge of the deck is moved 2 in. (50 mm) if the parapet slip form option is used. (See Art. 503.11) \_\_\_\_\_

i. Expansion Joints

- (1) When plates, angles or other structural shapes are specified, are they set to correct position, elevation and rigidly attached to bulkheads set to provide plan opening at 50 °F (10 °C) prior to concrete placement? (See Art.503.10(c) and bridge plan detail) \_\_\_\_\_

- (2) If temporary expansion joint bulkheads are attached to adjacent deck slabs or abutments for support, is the Contractor cutting the attachments as soon as the concrete has set to prevent joint damage due to horizontal expansion? \_\_\_\_\_

**5. PRE-POUR MEETING**

Prior to (preferably the day before) placement of deck concrete, a meeting will be held with the Contractor to review the following deck placement procedures (see Attachment 1 for sample pre-pour meeting agenda):

a. Mix

- (1) Have you discussed the properties of the proposed concrete mix (retarder, strength, water/cement ratio, etc.) with the District Materials Engineer and the Contractor? \_\_\_\_\_
- (2) Have you discussed with the Contractor the air, slump and strength requirements for deck concrete and the location for a suitable site to run tests? \_\_\_\_\_

b. Concrete Delivery

- (1) Is the delivery commitment from the ready mix supplier adequate so that the operations of placing and finishing will be continuous? (See Art. 503.07, Art. 1020.11(d)(9)) \_\_\_\_\_
- (2) Does the Contractor have sufficient equipment and labor to maintain continuous concrete placement operation between expansion or construction joints specified? (See Art. 503.16) \_\_\_\_\_

c. Pumped Concrete (Construction [Memorandum No. 74](#))

- (1) Is the Contractor aware mortar used to provide initial lubrication for the line shall be wasted and not allowed to be placed in the deck? The wasted mortar shall not be placed in any stream or drainage way. \_\_\_\_\_
- (2) Is the Contractor aware when the horizontal placement method is used, the line shall have a piece of plywood placed under each pipe joint to prevent damage to the epoxy coated rebars and to catch concrete which oozes from the line when the joint is disconnected? Concrete dropping onto rebars shall be removed. It sets up rapidly and if paved over creates a weak spot in the deck. \_\_\_\_\_
- (3) Will the pump be at lower elevation than the concrete trucks to facilitate discharge from the truck without excessive water additions? Constructing near level ramps or excavating an area for the pump is helpful. \_\_\_\_\_
- (4) Is the Contractor aware no water shall be added to the pump hopper. If water is added, to remove a line blockage etc..., this concrete must be wasted. \_\_\_\_\_
- (5) Is the Contractor aware the use of aluminum pipes or tubes is strictly prohibited. (See Art. 503.07) \_\_\_\_\_
- (6) Does the discharge end of the pump have attached either an "S" shaped flexible or rigid conduit, a 90 degree elbow with a minimum of 10 ft. (3 m) of flexible conduit placed parallel to the deck, or a similar configuration approved by the Engineer? (See Art. 503.07 and CM Section 500) \_\_\_\_\_

- (7) Is the contractor aware the mortar factor shall not exceed 0.86? (See PCC Level III Technician Course – Manual of Instructions for Design of Concrete Mixes) \_\_\_\_\_
- (8) Has the procedure to establish a correction factor for air content loss (or gain) in the pump been discussed? At least the first three truck loads should be tested before and after the pumping to establish the correction factor. It should be rechecked every 50 cu. yd. (40 m<sup>3</sup>) or as conditions change. \_\_\_\_\_

d. Finishing Equipment & Requirements

- (1) On skewed multi-beam/girder bridges (with skew angle exceeding 45°, or skew angle exceeding 30° and pour width to span length ratio exceeding 0.8) are you checking the bridge plan general notes to determine if the deck concrete must be placed and finished parallel to the skew? \_\_\_\_\_
- (2) Does the finishing machine transversely finish the surface with either a rotating cylinder(s) or a longitudinal oscillating screed? (See Art. 503.16(a)(1) and 1103.13(a)) \_\_\_\_\_
- (3) Is the finishing machine in good mechanical condition and the crown checked? \_\_\_\_\_
- (4) Does the fogging equipment satisfy specification requirements and is it in good working order? (See Art. 5013.16, 1103.13(a), and 1103.17(k)) \_\_\_\_\_
- (5) Has the “dry” run been made to check rebar clearance? (See Art. 508.05, Art. 1103.13(a)) \_\_\_\_\_
- (6) Are adequate foot bridges for finishing, texturing and applying cotton mat curing blankets and available for the concrete finishers? (See Art. 503.16, 1020.13(a)(5), 1103.17(d)). \_\_\_\_\_
- (7) Are there enough vibrators to adequately consolidate the concrete? (See Art. 503.07) \_\_\_\_\_
- (8) Are the vibrators equipped by the manufacturer with a non-metallic head? Slip-on covers are not allowed. (See Art. 1103.17(a)) \_\_\_\_\_
- (9) Are long handled floats not less than 3 ft. (1 m) in length and 6 in. (150 mm) in width or hand operated floats not less than 10 ft. (3 m) in length and 6 in. (150 mm) in width provided? (Art. 503.16(a)(1)) \_\_\_\_\_
- (10) Is a burlap or artificial turf carpet drag being furnished for the initial surface texturing? (Art. 503.16(a)(3)) \_\_\_\_\_
- (11) Where longitudinal joints or transverse joints are constructed, will platforms supported on the lower slab form be constructed \_\_\_\_\_

so workers will not be permitted to stand or walk on projecting reinforcement bars? (See Art. 503.09)

\_\_\_\_\_

(12) If the Engineer determines workability cannot be obtained, will a device be available to apply water to the deck in a fine mist? (See Art. 503.16(a)(1))

\_\_\_\_\_

(13) Has the Contractor provided temperature, relative humidity, and wind speed measuring equipment? (See Art. 503.16)

\_\_\_\_\_

(14) Is the contractor aware leakage through forms onto beams or girders shall not be allowed to harden and shall be removed while in a plastic state.

\_\_\_\_\_

e. Manpower

Will the Contractor have adequate supervision and enough manpower to place and finish the deck concrete and place curing covering in the specified manner? Has the Contractor designated a person responsible for placing the curing covering? (See Art. 503.16 and 1020.13(a)(5))

\_\_\_\_\_

f. Deficiency Checklist

Have you informed the Contractor of any deficiencies not previously taken care of? (Forms, reinforcement, epoxy touch up, grade, equipment etc.)

\_\_\_\_\_

g. Curing

(1) Are there adequate cotton blankets, soaker hoses and white polyethylene sheeting (or burlap-polyethylene blankets) on the jobsite to cure the deck? (See Art. 503.17 and 1020.13(a)(5))

\_\_\_\_\_

(2) Does the contractor have an adequate water supply available on the job site? (See Art. 503.17 and 1020.13(a)(5))

\_\_\_\_\_

(3) Is the contractor prepared to immediately wet the cotton mats upon placement? (See Art. 503.17 and 1020.13(a)(5))

\_\_\_\_\_

h. Pour Sequence

Is the contractor aware, if they plan to deviate from the pouring sequence shown in the bridge plans or add a pouring sequence (i.e. add longitudinal or transverse construction joints not shown in the plans) they must submit a proposal in writing? The proposal requires approval from the Bureau of Bridges and Structures. (See Construction Memo. 07-64)

\_\_\_\_\_

**6. CONCRETE DECK PLACEMENT**

a. Revolution Requirements for Truck Mixers

- (1) Are you immediately inspecting the batch counter on all arriving truck mixers to ensure that the required number of revolutions at mixing speed has been obtained? (See Art. 1020.11(a)(2) and 1020.11(a)(5)) \_\_\_\_\_
- (2) Does the number fit within the allowable number of revolutions shown in the table below? \_\_\_\_\_

Time Minutes	60 Mixing Revs. Req'd. (Simultaneous Charging)		70 Mixing Revs. Req'd. (Separate Charging)		
	Min	Max	Min	Max	
10	60	119	70	119	
15	66	144	72	144	Agitating Speed
20	76	169	82	169	2-5 rev/min.
25	86	194	92	194	
30	96	219	102	219	Mixing Speed
35	106	244	112	244	5-16 rev/min.
40	116	269	122	269	
45	126	294	132	294	
50	136	319	142	319	
55	146	344	152	344	
60	156	369	162	369	

Whenever water or admixtures are added to the truck at the jobsite or the revolutions on the truck are not within the above chart, an additional 40 revolutions at mixing speed shall be put on the truck. (See Art. 1020.11(a)(2)) \_\_\_\_\_

b. Time of Haul

- (1) If the temperature of the air or concrete is 18 °C (65 °F) or higher, is a retarding admixture being used? (See Art. 1020.05(b)(1)) \_\_\_\_\_

- (2) Is all concrete which is being hauled in truck mixers or truck agitators being deposited within 60 minutes<sup>1,2</sup> from the time stamped on the tickets? (See Art. 1020.11(a)(7)) \_\_\_\_\_

Note 1: When the concrete temperature at point of discharge is below 65 °F (18 °C), the allowable haul time is 90 minutes. (See Art. 1020.11(a)(7))

When the concrete temperature at point of discharge is at or above 65 °F (18 °C), retarding admixture must be used, which brings the maximum haul time up to 90 minutes. (See Art. 1020.05(b)(1), and Art. 1020.11(a)(7))

- (3) If central-mixed concrete is being hauled in nonagitator trucks, is the concrete being deposited within 30 minutes? (See Art. 1020.11(a)(7)) \_\_\_\_\_

c. Concrete Temperature

Are temperature checks of the plastic concrete being taken? The allowable limits for structural concrete are 50 °F (10 °C) to 90 °F (32 °C). When insulated forms or blankets are used: 50 °F (10 °C) to 80 °F (25 °C). (See Art. 1020.14(b)) \_\_\_\_\_

d. Air Content Determination

Allowable air content in place = (5% - 8%) (See Art. 1020.04)

- (1) Is an air content test (per MTPM) made on every load? (See Sampling Schedule 3 Non-QC/QA Concrete in the PPG, Construction Memo. 07-74, and QC/QA of Concrete Mixtures Recurring Special Provision Schedule B note 9/) \_\_\_\_\_

- (2) Is an air content test (per MTPM) made when mix water or air entrainment admixture is added at the jobsite? \_\_\_\_\_

Note: A slump test, and air test is required when a strength specimen is made. (See Sampling Schedule 3 Non-QC/QA Concrete in the PPG and QC/QA of Concrete Mixtures Recurring Special Provision Schedule B note 8/)

- (4) If a pump or conveyor is used for placement, is an air loss correction factor being established and used according to the following (See Construction Memo. 07-74 and QC/QA of Concrete Mixtures Recurring Special Provision): \_\_\_\_\_

- (a) Test the first three truck loads delivered before and after transport by the pump or conveyor.

- (b) Once the correction factor is determined, it shall be rechecked after an additional 50 cu yd (40 m<sup>3</sup>) is pumped, or an additional 100 cu yd (80 m<sup>3</sup>) is conveyed.

- (c) The correction factor should also be rechecked when significant changes in temperature, distance, pump or conveyor arrangement, etc., have occurred.
- (d) The air content should be near the midpoint of the range, after the correction factor has been applied. If the air content is not near the midpoint, adjustments are needed at the plant. If air content tests indicate significant air loss, the problem should not be solved by increasing the air content above the upper specification limit. A lower slump concrete or change in pump arrangement can cause less air loss. Thus, the air content at the discharge end could exceed the upper specification limit. The best alternative is to reduce air loss by changing the pump arrangement, or by making minor mix adjustments at the plant.
- (e) Record the actual test results. For before and after tests used to establish the correction factor, record both sets of tests, but report only the on-the-deck tests to the MISTIC system. Once the correction factor has been established, record the air tests results at the truck, as well as the correction factor used in accepting the truck's air content, but report only the corrected air content to the MISTIC system.
- (f) If the correction factor is 3 percent or more the Contractor shall take corrective action to reduce the loss of air content during transport by the pump or conveyor.

e. Slump Test

Allowable slump = 2 - 4 in. (50 - 100 mm) for Class BS without high-range water reducing admixture. (See Art. 1020.04)

The maximum slump may be increased to 7 in. (175 mm) when a high range water-reducing admixture is used. (See Art. 1020.04 note 4)

(1) On non-QC/QA jobs, is a slump test (per MTPM) made at least once each 50 cu. yd. (40 m<sup>3</sup>) min.? (See Sampling Schedule 3 Non-QC/QA Concrete in the PPG)

\_\_\_\_\_

(2) Is a Slump test made (per MTPM) when mix water is added at the jobsite?

\_\_\_\_\_

Note: A slump test and air test is required when a strength specimen is made. (See Sampling Schedule 3 Non-QC/QA Concrete in the PPG and QC/QA of Concrete Mixtures Recurring Special Provision Schedule B note 8/)

On QC/QA jobs, the sampling and testing frequency is in accordance with the QC/QA of Concrete Mixtures Recurring Special Provision.

f. Water/Cement Ratio Control

Has the Proportioning Technician or QC personnel at the plant communicated to you and the jobsite QC personnel, the permissible amount of water which can be added at the jobsite without exceeding the allowable water/cement ratio for the concrete mix? The specification requirement for a 4-inch (100 mm) slump still remains in effect and must be considered when adding water. (Art. 1020.04)

\_\_\_\_\_

g. Adding Water or Admixture to Trucks at Jobsite

When water or admixtures are added to the ready-mix truck at the jobsite, is the concrete to be mixed 40 additional revolutions at mixing speed to assure proper mixing? Concrete that is modified at the jobsite after testing so as to alter test results significantly, shall be re-tested for acceptance. (See Art. 1020.11(a)(2))

\_\_\_\_\_

h. Strength Test

On non-QC/QA jobs are either concrete test beams or cylinders being cast at the site of work and the following requirements met? (Art.1020.09)

\_\_\_\_\_

- (1) Modulus of Rupture (6 x 6 x 30 in. (150 x 150 x 750 mm) beam):

Cast 2 beams per pour. (Sampling Schedule 3, Non-QC/QA Concrete in the PPG)

\_\_\_\_\_

Are the beams being made, cured, and tested in accordance with the methods given in the Manual of Test Procedures for Materials (MTPM)?

\_\_\_\_\_

Designed flexural strength = 675 p.s.i (4,650 kPa) in 14 days. (See Art. 1020.04). Record beam tests in "Field Record Book of Modulus of Rupture Tests of Concrete Beams," Form LW-3.

\_\_\_\_\_

- (2) Compressive Strength 6 in. (150 mm) diameter x 12 in. (300 mm) cylinder: Cast 2 cylinders in lieu of each beam, i.e. 4 cylinder per pour. (See Sampling Schedule 3 Non-QC/QA Concrete in the PPG)

\_\_\_\_\_

Are the cylinders being made, cured, and tested in accordance with the MTPM?

\_\_\_\_\_

Designed compressive strength = 4000 p.s.i. (27,500 kPa) in 14 days (See Art. 1020.04)

Note: Submit MISTIC Form MI-655 - "P. C. Concrete Strengths," to the District Materials Engineer

It is highly recommended to make additional beam or cylinder test specimens, in case of damage to specimens or low strength test results.

i. Concrete Delivery Tickets

- (1) Are all truck tickets being collected and retained? \_\_\_\_\_
- (2) Do concrete tickets show section number, time of batch, batch quantity, truck number, etc.? \_\_\_\_\_

The QC/QA Recurring Special Provision requires the following information to be recorded on each delivery ticket or in a bound hardback field book: initial/final revolution counter reading, at the jobsite, if the mixture is truck mixed; time discharged at the jobsite; total amount of each admixture added at the jobsite; and total amount of water added at the jobsite.

- (3) Are you recording on each truck ticket the inspector's initials, the results of air/slump tests, concrete temperature checks, time of discharge, water or admixtures added, drum revolutions of transit mix trucks upon arrival and strength specimens taken? \_\_\_\_\_
- (4) Are all jobsite air, slump, water or admixture additions and beam test results being submitted to the proportioning technician daily for posting on MISTIC Form [MI 654](#), Concrete, Air, Slump Quantity and Form [MI 655](#), P. C. Concrete Strengths. \_\_\_\_\_

j. Placing Concrete

- (1) Is the concrete being bucketed, conveyed, pumped or otherwise placed in such a manner as to avoid segregation and is not being allowed to drop more than 5 ft. (1.5 m)? (See Art. 503.07) \_\_\_\_\_

Note: All skewed multi-beam/girder bridges, not just those required to be struck off and finished parallel to the skew per a bridge plan general note, should have the concrete placed parallel to the skew provided plasticity throughout the screeding operation and the uniformity of the tining can be maintained satisfactorily.

- (2) If the distance between the placement of concrete and the covering of the finished concrete nears 35 ft. (10.7 m), or 25 ft. (7.6 m) for deck widths greater than 50 ft. (15 m), are you ensuring placement of concrete is halted until the curing operation catches up? (See Art. 503.16) \_\_\_\_\_
- (3) Are you checking the evaporation rate based on measurements of air temperature, humidity, and wind speed? \_\_\_\_\_

- (4) When the evaporation rate is 0.1 lb/sq ft/hour (0.5 kg/sq m/hour) or greater, or when required by the Engineer, is the fogging equipment in operation? (See Art. 503.16) \_\_\_\_\_
- (5) Is the fogging equipment functioning properly and not accumulating water on the surface of the concrete. \_\_\_\_\_
- (6) If there is a delay of more than ten minutes during concrete placement, is wet burlap used to protect the concrete until operations resume? (See Art. 503.16) \_\_\_\_\_
- (7) Is the contractor removing all concrete leakage onto beams or girders while the leakage is in a plastic state? (See Art. 503.07) \_\_\_\_\_

k. Consolidation

- (1) Is all concrete being compacted with hand operated spud vibrators immediately after it has been placed? (See Art. 503.07) Over-vibration causes segregation and loss of entrained air. \_\_\_\_\_
- (2) At expansion angles or expansion joint blockouts is the concrete being vibrated through the vent holes to release as much trapped air as possible? \_\_\_\_\_

l. Strike-Off and Finishing

- (1) Is the finishing machine in proper adjustment and producing the specified surface? \_\_\_\_\_
- (2) If a vibratory screed is being utilized in lieu of a power driven finishing machine is bridge deck pour width less than 16 ft.? The vibrator must shut off when the speed is stopped so air will not be vibrated out of the concrete and excess mortar will not be brought to the surface. (See Art. 503.16(a)(1)) \_\_\_\_\_

Note: A vibrating screed may be used when the bridge deck pour is wider than 16 ft. with permission of the Central Bureau of Construction. (See Construction Memo. 07-73) \_\_\_\_\_

- (3) Are you ensuring that the concrete surface at parapets, curbs, sidewalks and medians is struck off during the deck pour and that excess concrete, mortar, or paste from the finishing process is not discarded into these areas? (See Art. 503.16(a)(1)) \_\_\_\_\_

m. Depth Checks

- (1) Are you checking the deck thickness and rebar depth at frequent intervals behind the finishing machine and recording these measurements in your deck pour field book? \_\_\_\_\_

(2) If deck thickness or rebar depth deficiencies are found, is the Contractor immediately notified so corrective action can be taken? \_\_\_\_\_

n. Longitudinal Finishing and Testing

(1) Is the contractor testing the entire surface for trueness with a 10 ft. (3 m) straightedge and correcting any depressions or high areas? (See Art. 503.16(a)(2)) \_\_\_\_\_

Note: The Contractor may, at their option, transversely float the entire surface with a hand-operated float having blades not less than 10 ft (3 m) in length and 6 in. (150 mm) in width. If the Contractor chooses to transversely float the entire surface with the 10 ft (3 m) hand float and surface corrections are made, straightedge testing while finishing will not be required.

(2) Are you prohibiting long handled floats with short length blades 3 ft. (1 m) from being used over the entire deck surface? These floats should only be used when necessary to smooth and fill in porous or open-textured areas as these floats create bumps in the deck surface. (See Art. 503.16(a)(1)) \_\_\_\_\_

o. Controlling Finish Water

(1) Are you prohibiting water from being applied to the deck surface unless it can be demonstrated that workability cannot be obtained? (Art. 503.16(a)(1)) \_\_\_\_\_

(2) If water is permitted is it being applied in a fine mist from a sprayer and not by brushes or other methods which concentrates water? (Art. 503.16(a)(1)) \_\_\_\_\_

p. Surface Texturing

(1) Is the deck surface being textured with either a burlap or artificial turf carpet drag (parallel to the centerline of the roadway) in the plastic state? (See Art. 503.16(a)(3)a.) \_\_\_\_\_

(2) After the required curing and protection, is the deck being grooved, by a mechanical saw device, perpendicular to the centerline of the roadway? (See Art. 503.16(a)(3)b.) \_\_\_\_\_

(3) Is the grooving being stopped 1 ft. (300 mm) from the face of the curbs or parapets and 2 in.  $\pm$  1 in. (50 mm  $\pm$  25 mm) from deck drains and expansion joints? (See Art. 503.16(a)(3)b.) \_\_\_\_\_

(4) Is slurry being picked up continuously, with vacuum equipment, during the deck grooving operation and disposed of offsite according to Art. 202.03? (See Art. 503.16(a)(3)b.) \_\_\_\_\_

(5) Is the deck being flushed with water as soon as possible to remove any slurry material not collected by the vacuum? \_\_\_\_\_

Discharge into any stream or drainage way is prohibited. (See Art. 503.16(a)(3)b.)

\_\_\_\_\_

q. Curing Bridge Decks

Per Art. 1020.13(a)(5) Wetted Cotton Mat Method:

(1) Is a separate foot bridge available for the placement of the cotton mats? \_\_\_\_\_

(2) Is the Contractor placing dry or damp cotton mats as soon as the surface of the concrete has been finished and textured? Are the mats being placed in a manner which will not mar the concrete surface? \_\_\_\_\_

(3) Are you ensuring the distance between placement of the concrete and the placement of the cotton mats does not exceed the allowable distances of 35 ft (10.7 m) (or 25 ft. (7.6 m) for pour widths greater than 50 ft. (15 m)). (See Art. 503.16) \_\_\_\_\_

(4) Immediately after placement, are the cotton mats being wetted thoroughly with a gentle spray of water? Are the mats maintained in a wetted condition until the soaker hoses can be placed? \_\_\_\_\_

(5) When the concrete has hardened sufficiently, are soaker hoses being placed at a maximum 4 ft. (1.2 m) spacing? \_\_\_\_\_

(6) After placement of the soaker hoses, are the cotton mats being covered with white polyethylene sheeting or burlap-polyethylene blankets? \_\_\_\_\_

(7) For areas inaccessible to the cotton mats, is curing being done using the burlap method as per Art. 1020.13(a)(3)? \_\_\_\_\_

r. Bonded Construction Joints

(1) Is the surface of the existing concrete (or hardened concrete from the first pour) being properly prepared in accordance with Art. 503.09(b)? \_\_\_\_\_

Is the surface being prepared by washing with water under pressure or by sandblasting to expose clean, well bonded aggregate? \_\_\_\_\_

Note: Removal of cement paste from the first pour may be facilitated by coating the form of the first pour with approved surface retarder, or applying surface retarder directly to the exposed surface of the first pour. \_\_\_\_\_

(2) Has the prepared surface of the existing concrete been wetted and maintained in a dampened condition for a minimum of one

hour before the application of new concrete? (See Art. 503.09(b))

\_\_\_\_\_

(3) Immediately before placing the new concrete, is any excess water being removed? (See Art. 503.09(b))

\_\_\_\_\_

s. Protection

Is all deck concrete which is placed during the winter period (Dec. 1 thru March 15) being protected in accordance with one of the following methods?

\_\_\_\_\_

(1) Method I. The concrete and forms completely covered with insulating material enclosed on sides and edges with an approved waterproof liner. (Art. 1020.13(d)(1))

\_\_\_\_\_

(2) Combination Method I & II. The top of the deck shall be covered with insulating material. The sides and bottom of the deck shall be enclosed in adequate housing for 7 days. The air surrounding the concrete shall be kept between 50 °F (10 °C) and 80 °F (27 °C). (See Art. 1020.13(d)(1)&(2))

\_\_\_\_\_

Note: If the concrete is placed outside the winter period and the forecast for temperature is below 45 °F (7 °C), (or the actual temperature drops below 45 °F (7 °C)) and the concrete is less than 72 hours old the concrete shall be protected as above. (Art. 1020.13(d))

t. Parapets and Railings

(1) General

(a) Are you not allowing placement of concrete parapets until the deck forms have been removed? Note deck forms cannot be removed until the deck concrete has attained the required flexural strength and the 7 day curing period is complete. (See Art. 503.16(b), 503.06, and 1020.13)

\_\_\_\_\_

(b) Are you checking the locations for all expansion joints, handrail post bolts, and chamfer strips before permitting the Contractor to place concrete? (See Art. 503.16(b)(2))

\_\_\_\_\_

(c) Has the deck surface under the parapet been properly prepared for a horizontal bonded joint? Is the prepared surface soaked for an hour before the pour, and is excess water being removed immediately prior to placing concrete? (See Art. 503.09)

\_\_\_\_\_

(2) Formed Parapets and Railings

- (a) Are you ensuring all forms have good surface quality? Air pockets vibrated out of the concrete tend to cling even more to the sloped surfaces of parapet forms and a rough form surface worsens this situation. \_\_\_\_\_
- (b) Are you checking the forms prior to placement to ensure they are of the correct dimension, tight fitting, and properly aligned? (Art. 503.16(b)(2)) \_\_\_\_\_
- (c) Are you ensuring the proper clearance from the faces of the concrete? \_\_\_\_\_
- (d) Is the contractor placing the concrete in continuous horizontal layers and thoroughly vibrating the concrete in each layer to ensure internal consolidation and minimize air pockets and honeycombing on the surface of the parapet? (Art. 503.07) \_\_\_\_\_
- (e) Are you rechecking the alignment of forms and grade of the top chamfer strips immediately after the placing of concrete in the forms to ensure all corners in the finished work shall be true, sharp and clean cut? (See Art. 503.16(b)(2)) \_\_\_\_\_
- (f) Are the parapets being cured 7 days with the waterproof paper, polyethylene sheeting, wetted burlap or wetted cotton mat method? (See Art. 1020.13) \_\_\_\_\_  

(See also Art. 1020.13 table note 8/regarding non-traffic surfaces receiving a protective coat according to Art. 503.19)
- (g) Are all depressions resulting from the removal of ties, rods or bolt anchorages and all air pockets or rough places larger than 1/2 in. (13 mm) being carefully and neatly pointed with matching mortar? (Art. 503.15) \_\_\_\_\_
- (h) Are all parapet and railing surfaces that will be exposed to view after completion of the work being given a normal finish consisting of the removal of all fins, rough spots, stains, hardened mortar or grout, and form lines by rubbing with a #16 carborundum stone or equal? (See Art. 503.15(a)) \_\_\_\_\_

If the surface of concrete is oil-stained, or is otherwise not of uniform color, it may require cleaning utilizing a grout rub. The grout shall be 1 part cement (from the original source) to 1½ parts fine sand with sufficient water to produce a grout with the consistency of thick paint. At the end of the cleaning operation there shall be no visible film of grout remaining.  
(See Art. 503.15(a))

(3) Slip Formed Parapets (General)

- (a) Is there a bridge plan general note stating slipformed parapets are not allowed? If there is a bridge plan general note stating slipformed parapets are not allowed, under no circumstance is slipforming to be allowed. \_\_\_\_\_
- (b) Is the "Slipform Parapet" special provision included in the contract? If the contract does not contain either the slipform parapet special provision or a general note prohibiting slipformed parapets, contact the Central Bureau of Construction to determine if slipforming should be allowed as an alternate method of construction. \_\_\_\_\_

(4) Slipform Parapet (See Slipform Parapet Special Provision)

- (a) Is the rebar cage tied at all bar intersections? This is necessary to maintain rigidity during concrete placement. The contractor may use additional epoxy coated stiffening reinforcement bars to prevent movement of the reinforcement cage subject to your approval. Significant movement of the cage during slipforming will be cause for immediately ceasing the slipforming operation. \_\_\_\_\_
- (b) Are you checking the slipform equipment to make sure the proper dimensions will be placed? \_\_\_\_\_  
  
In particular, are you making sure the breakline between the base of the parapet and upper portion of the parapet on the face of the parapet does not exceed the plan dimension? This dimension is critical. \_\_\_\_\_
- (c) Does the slipform machine have automatic horizontal and vertical grade control? \_\_\_\_\_
- (d) Has the contractor performed a dry run for the full distance of the anticipated pour, checking for the proper clearance between the rebar and the slipform? \_\_\_\_\_
- (e) Are the ends of the parapet formed and the forms securely braced? Are parapet sections at light standards formed for a minimum distance of 4 ft (1.2 m) on each side of the discontinuity? \_\_\_\_\_
- (f) Is the slipform machine running at speeds within the specification limits? \_\_\_\_\_
- (g) Is the vertical surface at the base of the barrier (within 3 in. of the deck) being troweled true after passage of \_\_\_\_\_

the slipform machine? Hand finishing of minor sporadic surface defects may be allowed? \_\_\_\_\_

Any visible indication that less than specified cover of concrete over the reinforcing bars has been obtained, or of any cracking, tearing or honeycombing of the plastic concrete, or any location showing diagonal or horizontal cracking will be cause for rejection of the parapet section in which they are found.

(h) Is the specified clearance between the rebar and the slipform being maintained without external force throughout the pour? \_\_\_\_\_

If proper clearance cannot be maintained without external force, the slipform operation shall stop until the rebar cage is adjusted to obtain the proper clearance.

(i) Are you checking that the rebar cage is not moving longitudinally during the slipform operation? \_\_\_\_\_

Excessive movement of the rebar cage during the slipform operation shall be cause for removal and replacement of the affected section.

(j) Is the actual longitudinal alignment within tolerance? \_\_\_\_\_

(k) Are abrupt changes in actual longitudinal alignment of 1/2 in. in 10 ft. (13 mm in 3 m) being removed and replaced? \_\_\_\_\_

(l) Are all surfaces being checked with a 10 ft. (3 m) straight edge furnished and used by the Contractor as the concrete is extruded from the slipform? \_\_\_\_\_

(m) Are variations greater than 1/4 in. in 10 ft. (6 mm in 3 m) being corrected immediately? Continued variations in the barrier surface exceeding 1/4 in. in 10 ft. (6 mm in 3 m) will not be permitted and remedial action shall immediately be taken to correct the problem. \_\_\_\_\_

(n) Are any deformations or bulges remaining after initial set being removed by grinding after the concrete has hardened? \_\_\_\_\_

(o) Is the parapet being cured according to the special provision? \_\_\_\_\_

(p) Have random cores been taken to verify the quality of the slipform parapet? \_\_\_\_\_

u. Surface Variations

- (1) At the end of the curing or protection period, are you testing the surface of the deck with a 16 ft. (5 m) straightedge? (See Art. 503.16(a)(4)) \_\_\_\_\_
- (2) Are variations greater than 3/16 in. (5 mm) being removed by grinding or cutting? (See Art. 503.16(a)(4)) \_\_\_\_\_

v. Expansion Joints

(1) Neoprene Expansion Joint Installation

- (a) Are the concrete surfaces on which the joint sets, dry, clean and free of dirt, grease, loose concrete and contaminants? (See Art. 520.07) \_\_\_\_\_
- (b) Is the concrete surface level and sound (no broken or spalled concrete) with adjacent joint seats in a common plane with each other? If not are the surfaces corrected by grinding or other approved procedures? (See Art. 520.07) \_\_\_\_\_
- (c) Are neoprene surfaces in contact with the adhesive/sealant bedding compound cleaned with acceptable solvent prior to installation and is the adhesive/sealant applied over the entire blockout? (See Art. 520.07) \_\_\_\_\_
- (d) Are nuts torqued to 65 ft.-lbs. (90 Nm) and after 24 hours of initial installation are the nuts retorqued to 65 ft.-lbs. (90 Nm)? (See Art. 520.07) \_\_\_\_\_
- (e) Are bolt wells, joints between units, around connecting bolts and cavity plugs cleaned and sealed in a neat manner? (See Art. 520.07) \_\_\_\_\_
- (f) Upon completion of the joint, are uneven end butt connections being ground flush? (See Art. 520.07) \_\_\_\_\_

(2) Preformed Elastomeric Compression Joint Seals

- (a) Is the seal installed with suitable hand or machine tools and secured in place in a clean joint with approved adhesive which covers both sides of the seal in contact with the sides of the joint? (See Art. 520.06) \_\_\_\_\_
- (b) Is the seal installed in one continuous piece with no more than one manufacturer's splice? (See Art. 520.06) \_\_\_\_\_

(3) Preformed Elastomeric Strip Seals

- (a) Is the steel extrusion cavities being kept clean and dry until the strip seal is placed? (See Art. 520.08) \_\_\_\_\_
- (b) Are the "locking ears" portion of the strip seal gland being coated (and installed) with an adhesive/lubricant in 5 ft. (1.5 m) maximum intervals to ensure the adhesive/lubricant does not dry prior to installation? (See Art. 520.08) \_\_\_\_\_

w. Protective Coat

- (1) Is PROTECTIVE COAT, when specified, being applied to the entire top surface of the bridge deck, hubguards and to the tops and inside vertical faces of the sidewalk, parapets, end posts, and wings? (See Art. 503.19) \_\_\_\_\_
- (2) Is the protective coat being applied in two applications at 50 sq. yds. per gal. (11m<sup>2</sup>/L)? (See Art. 503.19) \_\_\_\_\_
- (3) Is the protective coat being applied when the temperature is above 40 °F (4 °C)? (See Art. 503.19) \_\_\_\_\_
- (4) Is the protective coat being applied on clean, dry concrete, which is at least 14 days old, after bridge deck grooving but before the bridge deck is marked ? Note there should be a 48 hour drying period since the last rain (See Art. 503.19) \_\_\_\_\_

x. Field Painting of Structural Steel

Is the steel being cleaned, spot painted and given the application of the additional paint coatings required by the contract? (Art. 506.05) \_\_\_\_\_

7. **DOCUMENTATION OF FINAL CONTRACT QUANTITIES**

CONCRETE STRUCTURES- Cubic Yard (Cubic Meters)

CONCRETE SUPERSTRUCTURE - Cubic Yards Cubic Meters

REINFORCEMENT BARS - Pounds (Kilograms)

REINFORCEMENT BARS, EPOXY COATED - Pounds (Kilograms)

BAR SPLICERS - Each

- a. Are computations based on plan dimensions in a permanent file to verify plan quantities? \_\_\_\_\_

If your computations are not reasonably close to plan quantity, within 0.3 cu. yd. (0.2m<sup>3</sup>) for Concrete and 10 lbs. (4.5 kg) for Reinforcement Bars are your calculations being checked by another person to verify the revised quantity? \_\_\_\_\_

Are you indicating in your records that the structure was “Built to plan dimensions.” Otherwise, are you showing revised dimensions? \_\_\_\_\_

Are you computing the weight of reinforcing bars using the theoretical weight as listed in Art. 508.07? \_\_\_\_\_

b. In lieu of all of the above, do you have a jointly-signed Form [BC 981](#) agreeing to plan quantities for appropriate pay items to document the final pay quantity? \_\_\_\_\_

PROTECTIVE COAT - Square Yards (Square Meters)

NEOPRENE EXPANSION JOINT - Foot (Meter)

PREFORMED JOINT SEAL - Foot (Meter)

PREFORMED JOINT STRIP SEAL - Foot (Meter)

a. Have field measurements of all applicable pay items been taken? \_\_\_\_\_

Have the field measurements and computations been retained in a permanent file? \_\_\_\_\_

b. In lieu of all of the above, do you have a jointly-signed Form [BC 981](#) agreeing to plan quantities for appropriate pay items to document the final pay quantity? \_\_\_\_\_

FURNISHING STRUCTURAL STEEL - Lump Sum

ERECTING STRUCTURAL STEEL - Lump Sum

FURNISHING & ERECTING STRUCTURAL STEEL - Lump Sum

FURNISHING & ERECTING STRUCTURAL STEEL - Pounds (Kilograms)\*

\*This pay item is used for minor pay items of structural steel such as expansion dams on concrete bridges or miscellaneous steel for the repair of existing structures. The pounds (kilograms) of structural steel shall be determined using the approved shipping weight (mass) or by measuring on an approved platform scale (unless the quantity is less than 10,000 lb. (4500 kg)). (See Art. 505.12)

Designers are supposed to include the weight of bolts, nuts, and washers in the estimated structural steel quantity calculation

ELASTOMERIC BEARING ASSEMBLY – Each

ANCHOR BOLTS - Each

FURNISHING & ERECTING PRECAST, PRESTRESSED CONCRETE I-BEAMS (Depth Specified) - Foot (Meter)

FURNISHING & ERECTING PRECAST, PRESTRESSED CONCRETE BULB T-BEAMS (Depth Specified) - Foot (Meter)

PRECAST, PRESTRESSED CONCRETE DECK BEAMS (Depth Specified) - Foot (Meter)

In determining the total length to be paid for, the specified overall length of the individual beams will be used.

In lieu of measured quantities, do you have a jointly-signed Form [BC 981](#) agreeing to beam plan quantities to document the final pay quantity? (See Art. 504.07).

**DECK PREPOUR MEETING AGENDA**

(Rev. 3/1/09)

Length \_\_\_\_\_ Width \_\_\_\_\_

Date: \_\_\_\_\_

Time: \_\_\_\_\_

Contact: \_\_\_\_\_

**AGENDA**

What is the scheduled date of the pour? \_\_\_\_\_ Time? \_\_\_\_\_

**1. DISCUSS PLAN NOTES AND SPECIAL PROVISIONS****a. Pour Sequence Concerns**

The addition of a pour sequence (i.e. the addition of longitudinal or transverse joints) or use of a pour sequence that differs from a pour sequence shown in the contract plans must be approved by Bureau of Bridges and Structures.)

**b. QC/QA Concrete – discuss roles relating to control of materials and construction.****2. EQUIPMENT**

a. Bidwell? \_\_\_\_\_ Gomaco? \_\_\_\_\_ Screed? \_\_\_\_\_

(1) Discuss auger height (1/8 to 1/4" above roller)

(2) Discuss roller (1/8" higher in back)

(3) Discuss roller rotation

(4) Is equipment in good working order?

**b. Skew Placement Concerns**

(1) &gt;45 degrees (or &gt;30 degrees with pour width to span length ratio exceeding 0.8); check bridge plan general notes for special finishing requirements

(2) &lt;45 degrees

(3) Have proper adjustments been made to the finishing machine

a. Heavily skewed decks should be finished from leading end to trailing end.

b. Finishing should be from low side to high side of superelevated decks.

c. Dry Run Concerns

- |     |  |      |
|-----|--|------|
| (1) | check rebar clearance  | Inch |
| (2) | check deck thickness   | Inch |
| (3) | check deck drain clearance   | Inch |
| (4) | check for rail deflection  |      |
| (5) | check fogging system for performance (verify all nozzles work, shut-off system functions and nozzles do not leak.) Nozzles should not point straight down. |      |
| (6) | check rebar for ties, epoxy touch ups, etc.  |      |
| (7) | check for hydraulic leaks and other equipment problems   |      |
| (8) | check rail supports to ensure stability  |      |

d. Fogging System Concerns

Note: Fogging is required unless evaporation rate is less than 0.1 lb/sq.ft./hr. Fogging increases humidity at deck surface. Fogging reduces plastic and dry shrinkage cracking caused by high temperature, low humidity, and high wind.

- (1) Use Portland Cement Association's publication "Design and Control of Concrete Mixtures" – section on plastic shrinkage cracking to determine the evaporation rate.
- (2) Repair leaks to avoid ponding water
- (3) Fogging system should be in accordance with Art. 1103.17(k) (No baptizing!)

e. Foot Bridges – minimum 2 required

- (1) Finishers
- (2) Burlap / Artificial Turf Carpet Drag and Curing

f. Plastic Texture

Burlap or artificial turf carp should be dragged parallel to centerline of roadway.

g. Air Meter Concerns

- (1) Have the air meters been calibrated and correlated?

- (2) Are there a backup air meters that have been calibrated and correlated?

Correlation should include all primary and secondary/backup meters from the plant, contractor and state. All meters should read within 0.9%

#### h. Concrete Pump Concerns

- (1) Waste initial mortar in approved location (not the deck or water way)
- (2) Plywood under all pipe joints
- (3) No water hosed into hopper
- (4) No aluminum pipes
- (5) Air test required at both ends to determine air loss correction factor (first 3 loads + every additional 50 cu. yd.)
- (6) Required "S" shaped outlet or 90 degree elbow and hose; Purpose to control air loss, prevent segregation, and reduce the potential for damage to epoxy coated reinforcement
- (7) What is backup/breakdown procedure? (i.e. bucket or additional pump)

#### i. Mix Concerns

- (1) Air Content decreases as boom angle decreases
- (2) Temperature Control

#### j. Concrete Conveyer Concerns

- (1) Adequate covering to collect spilled concrete
- (2) DO NOT run conveyer out over placed concrete (spillage)
- (3) Avoid reinforcement bar damage from conveyer supports and conveyer section stacking

#### k. 10 foot straight edges...how many?

- l. Floating entire surface with 10' float optional, - Floating entire surface with 3' float is not allowed

#### m. Bonded Construction Joints

- (1) First Pour-finish smooth, spray retarder on joint surface within 30 minutes after concrete placement
- (2) Next Day- Pressure wash to expose aggregate
- (3) Second Pour- wet first pour joint surface and keep damp for at least one hour prior to second pour

## n. Phone Concerns

- (1) Is a phone available to call the ready-mix plant?
- (2) Is adequate service/signal available for cell phones?
- (3) What is the ready-mix plant phone number?

## o. Vibrator Concerns

- (1) Do all vibrators have non-metallic heads coated by the manufacturer (BDE)?
- (2) Slip-on head covers are not allowed.
- (3) Are back-up vibrators available and approved?

**3. FRAMING, RAILS AND REBAR**

## a. Cantilever Forming Bracket Concerns

- (1) Leg brace of cantilever bracket shall bear on the web within 6" of bottom flange
- (2) #4 epoxy tie bars required @ 4' to 8' c-c (4' max. when finishing machine rails are located outside exterior steel beams/girders)
- (3) Place ties between top and bottom layers of deck reinforcement. For decks with cross slopes, it may be necessary to anchor the ties on the exterior girders and on the girders adjacent to the cross slope crown.
- (4) Draw ties taut until tie bar does not vary from a straight line.
- (5) Use fabricated brackets to anchor ties (no welding to studs or PPC beam reinforcement bars)
- (6) Alternate tie procedures must be submitted for approval with design calculations and detailed plans
- (7) Cable not allowed (too much elongation)
- (8) 4x4's required between exterior and first interior beams at tie locations
- (9) All accessories being permanently incorporated should be epoxy coated or galvanized
- (10) Coat forms with form oil prior to placing reinforcement

## b. Reinforcement Bar Concerns

- (1) Discuss epoxy coating inspection procedure
- (2) Repair nicks and cuts

- (3) Cut skew rebar...Shear cut – No flame cutting allowed
- (4) 100% ties? Less than 12"spacing, alternate intersections ok  
(Use multiple twists to assure bars stay tied under foot traffic)
- (5) #9 tiedown wire @ 25' longitudinal & 15' transverse spaces
- (6) Chairs...continuous 3' bottom or top. 2'x3' spacing for top mat ok  
(Top mat chairs are required to be placed on formwork. Not on bottom mat of steel.)
- (7) Protect epoxy coating
  - (a) Is plywood available?(Best Practice)
  - (b) Avoid using rebars to clean come-alongs and other hand tools
  - (c) Rubber coated vibrators

c. Rail Support Concerns

- (1) Where are rail supports placed?
- (2) Avoid rails within pour when possible  
(Causes problems with consolidation, hand finishing and delays curing placement)  
(Rails must be placed directly on W27 and smaller steel beams)
- (3) Avoid having to stand in mix to finish
- (4) How and where are supports attached? (Epoxy? No field welding)
- (5) What is the center to center distance?
- (6) Is the rail rigid?

g. Plywood walkways on 4x4 supports?

(Walking on projecting reinforcement bars can fracture the concrete after the initial set)

#### 4. CURING

a. Wetted Cotton Mat Method (Required)

- (1) Do not over finish concrete
- (2) Cover IMMEDIATELY

- (3) Who is the contractor's supervisor responsible for covering and curing the deck?
  - (4) Do we have adequate dedicated labor?
  - (5) Pre-Wet Cotton Mats (Best Practice) or SOAK immediately.
    - (a) Mats must be thoroughly soaked. Use adequate water.
    - (b) Delayed wetting can cause mats to wick water away.
  - (6) Keep blankets within 35' of finishing machine (25' for decks wider than 50') or stop placement to catch-up.
  - (7) Emphasize timely covering include very beginning of pour
  - (8) Soaker Hoses every 4' max.
  - (9) Is there a continuous water supply-how will it be keep wet overnight/weekend?
  - (10) Cover cotton mats and soaker hoses with white polyethylene sheeting or burlap-polyethylene blankets
- b. Low Air Temperature Protection Concerns
- (1) Required when air temperature is below 45 °F within 72 Hrs. (predicted or actual)
  - (2) Required during Winter Period of December 1 – March 15
  - (3) Review Protection Method 1 and 2
  - (4) Contractor responsible for concrete damage by cold
  - (5) Means for checking concrete temp during curing required

## **5. PLACEMENT**

- a. Wet the wood deck prior to concrete placement
- b. Leakage onto beams or girders must be removed when in the plastic state – to avoid damage to primer/paint system
- c. Compressor available to blow off dried concrete
- d. Remove splattered concrete from deck and parapet reinforcement bars – typically with burlap
- e. Reinforcement bars must remain clean of mud
- f. Avoid walking in finished/vibrated concrete
- g. Mortar/Cream Concerns

- (1) Mortar/cream from finishing machine rollers shall be removed from the deck
  - (2) The mortar/cream should not be wasted in sidewalk, median, or parapet areas etc...
- h. Vibrator Insertion Concerns
- (1) Insert vibrators vertical for 3-5 seconds to remove entrapped air, not entrained air
  - (2) Do not drag vibrators – this leads to segregation of mix
  - (3) Do not use vibrators to move concrete
- i. Probe & Record deck thickness
- j. Air & Slump Concerns
- (1) Need test area
  - (2) No fly dumping
  - (3) Test each load
  - (4) Test before and after pumper – have a piece of plywood available for air test on deck
  - (5) What slump do you want at the deck?
  - (6) What air content do you want at the deck?
- k. Plastic Texture Concerns
- (1) Use burlap or artificial turf carpet drag
  - (2) Drag parallel to centerline roadway
- l. Saw Cut Grooving Concerns
- (1) Saw cut groove perpendicular to centerline roadway
  - (2) Pick up slurry
  - (3) Stop grooving 1' from face of curbs and parapets
  - (4) Stop grooving 2" ± 1" from drains and expansion joints
- m. Finishing Concerns
- (1) Do not over hand finish
  - (2) Set Machine Properly

- (3) No need to bull float – (floating entire surface is only permitted with floats 10' long or longer)
- (4) Check with 10 ft. straight edge
- (5) Avoid walking in finished concrete
- n. Emergency Procedures (Delays over 10 minutes)
  - (1) Concrete protection (wetted burlap available)
  - (2) Spare Parts for finishing machine
  - (3) Header available
  - (4) Header locations
- o. Parapet Area Concerns
  - (1) Avoid bidwell slop
  - (2) Rebar need to be cleaned of any splatter
  - (3) Discuss preparation of horizontal joint
- p. Place concrete uniformly - do not spread mix erratically on the deck
- q. If structure is skewed place concrete parallel to skew

## 6. **DELIVERY OF MIX**

- a. Mix Design Concerns
  - (1) Does the RE have a copy of the approved mix design?
  - (2) Are there any factors which require special construction needs?
    - (a) Long term retarding
    - (b) Pumping - When class BD concrete is to be pumped, the course aggregate gradation shall have a minimum of 45 percent passing the 1/2in. sieve as per article 1004.01(c) note 8/.
    - (c) Specialized concrete
  - (3) Have approved gradation tests been submitted from the plant stockpiles?
- b. Transit or Central Mix Plant
- c. Scheduled time for start of pour?
- d. Material Supply Concerns
  - (1) How much material is going to be needed?

- (2) At what rate?
  - (3) Haul time from plant?
  - (4) Are enough trucks available?
  - (5) Are enough materials available (cement, microsilicia, aggregates)?
- e. Addition of Admixtures Onsite Concerns
- (1) Discuss responsibility for adding admixtures on site
  - (2) Is adequate Air Entrainment Admixture (AEA) and Superplasticizer on site?
  - (3) Know your admixtures
    - (a) Compatability
    - (b) Dosage rates - One Oz. AEA/yd<sup>3</sup> normally raises air one percent
    - (c) 40 additional revs before testing
- f. Discuss responsibility for communicating with the plant
- (1) Mix and admixture changes
  - (2) Breakdowns
  - (3) Air Loss
- g. All concrete trucks must have working rev counters and sight tubes. Counters will be reset for each load.
- h. Delivery Ticket Concerns
- (1) Each delivery ticket shall be stamped with the batch time
  - (2) Best practice - Each delivery ticket should include plant test results
  - (3) Best Practice - Each delivery ticket should note the amount of water that can be added on-site
  - (4) Note when strength specimens are made in field
  - (5) Field Personnel should record rev count, time of discharge, total water added and total admixtures added
- i. All trucks will reverse their drums prior to loading.
- j. Discuss truck mixer revolutions
- k. If Type G admixture (superplasticizer with retarder) is used...No retempering will (with water or Type G admixture) be allowed.

- If Type F admixture (superplasticizer) is used...No retempering water will be allowed, Retempering will be with Type F only. Ensure retempering does not bust the maximum water/cement ratio
- l. Discuss use of retarder
  - m. Discuss haul time
  - n. Concrete Temperature Concerns
    - (1) No concrete will be placed with a mix temperature above 90 degrees
    - (2) Correlate all thermometers before pour
    - (3) Is enough ice available if necessary?
    - (4) Water stockpiles
    - (5) Retarder or 50% increase in water reducer required above 85 degrees
    - (6) No concrete will be placed with a mix temperature below 50 degrees
    - (7) Is enough hot water available
    - (8) Do aggregates need to be heated?
  - o. Aggregate gradation and moisture tests shall be ran prior to pour
  - p. Has a Dedicated concrete wash out area been established (with silt fence – best practice)?
  - q. Testing Concerns
    - (1) An air test will be performed on every load at the jobsite.
    - (2) Check slump for loss of workability
    - (3) A wheel barrow shall be available at testing site for obtaining more representative sample. (1/3 to 1/2 full)

## 7. **WEATHER**

- a. Hot and/or windy (and/or DRY) Weather Concerns
  - (1) AVOID pouring (prime cause of plastic shrinkage cracking)
  - (2) Fogging system required
  - (3) Pour at night
  - (4) Start very early in the morning
  - (5) Labor fatigue (will enough labor be available?)

**b. Rain Concerns**

- (1) Check forecast – should we AVOID pouring – why chance removal?
- (2) Who will decide to call off pour?
- (3) When will decision be made to call off pour?
- (4) Rain hitting the surface raises the water/cement ratio and causes scaling, and marring of the surface and ultimately a shorter deck life

**8. MISCELLANEOUS CONCERNS**

- (1) Review Construction Inspectors Checklist for Bridge Superstructures
- (2) Rules of Thumb?
- (3) Medians and Sidewalks need same attention to detail as rest of the deck
- (4) Discuss stage line joint preparation if applicable

(Excerpt from "Machine Setup, Models 2450-3600-4800 Concrete Paving Machine," Bid-Well, Division of CMI Corporation, Canton, SD)

**ADJUST ROLLERS AND DRAG PAN** – After the pour has started and the machine has moved out from the end bulkhead or has passed over the bulkhead the full length of the paving roller, raise the back of the machine 1/8 of an inch by turning the leg cranks 1/2 turn counterclockwise (See figures below). This will keep the rear of the paving rollers from digging in and leaving a small ridge of concrete. It may be necessary to readjust the augers, up or down, to obtain or reduce the roll of concrete. Optimum is golf ball size in diameter at the front of the paving roller. As the machine progresses into the pour and clears the bulkhead or end dam, attach the burlap or astrograss drag to the drag pan.

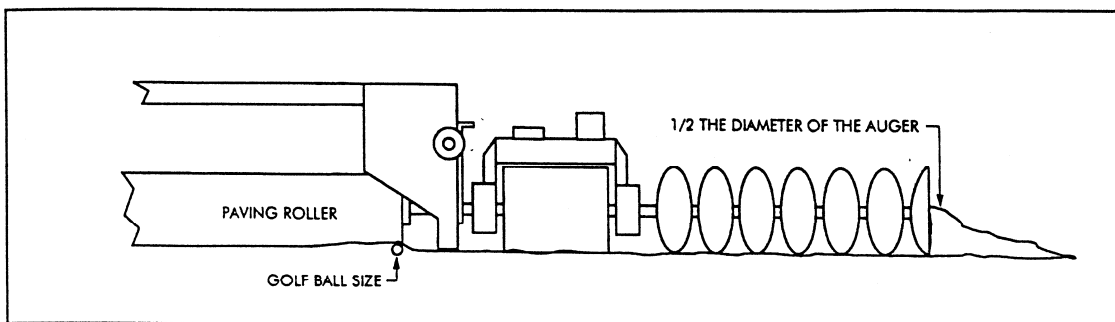
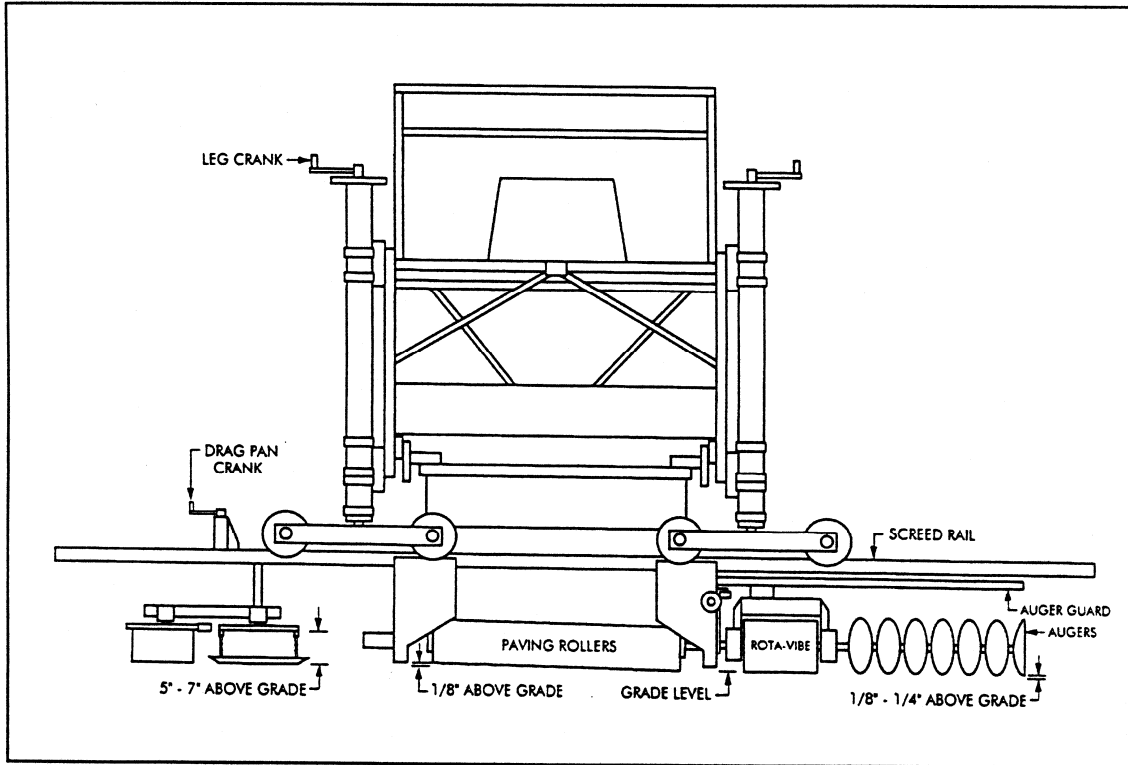

**NOTE:** The burlap drag should be wet. If new burlap is being used the burlap should soak in water for at least 24 hours. This will remove all oils in the burlap and make it more absorbent.

The texture given by the burlap can be easily adjusted. If the burlap is dragging too hard, remove one of the retaining tubes and roll up the burlap so that the drag is not so heavy. If the burlap does not seem to drag enough, increase the length of the burlap so that it hangs down more.

NOTE: If the drag pan H-Frame is too high or the chains are hooked too tight, the pan will have a tendency to hop as it is being dragged across the deck.

**ROLLER ROTATION** – The two paving rollers can rotate in the same direction (either clockwise or counter-clockwise) or they can rotate in opposite directions (See figure below).

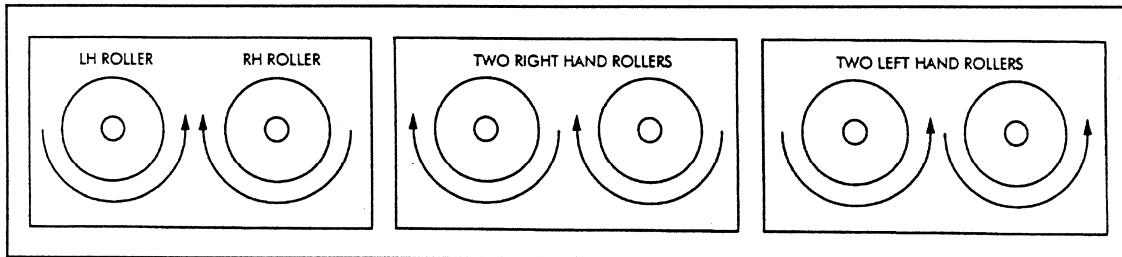

At the beginning of a pour it is recommended that you rotate the rollers in the same direction for the first couple of passes. Using the Roller Directional Valves, position the two valve levers in the same direction. Facing the augers, both rollers turn clockwise when the carriage travels to the left and counterclockwise when the carriage travels to the right. Put the Automatic Roller Reversing Valve in the "Reversing" position. The "Reversing" position will change the roller direction with each pass of the carriage. After a couple passes, change the direction of one roller. Which one will depend on the direction of the carriage travel (See figure below).

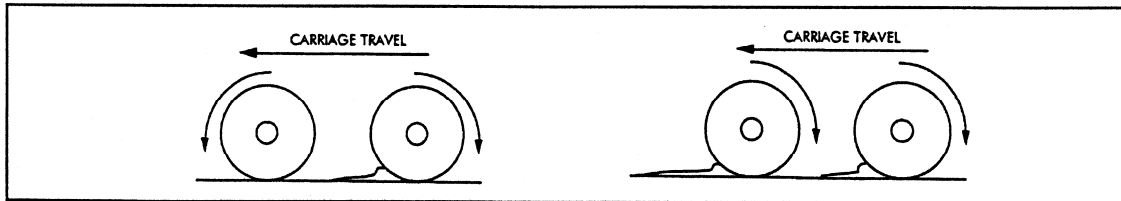

Put the Automatic Roller Reversing Valve in the "Non-Reversing" position. The "Non-Reversing" position does not change the roller direction with each pass of the carriage. Facing the augers, the right roller turns clockwise and the left roller turns counterclockwise. This allows the leading roller to consolidate the concrete and the trailing roller to pave the surface. Normally, when pouring a flat bridge deck or slab, this roller rotation will provide the best overall production and sealed finish. However, due to "mix," slump and other concrete variables one roller rotation option may work better than another. The paver's automatic pivot device will keep the excess material that the paving rollers carry moving out the front of the paving rollers instead of trailing off to the rear of the paving rollers. The pivot device can be adjusted for quickness by turning the set screws on the Automatic Roller Reversing Valve.

**SUPER ELEVATIONS** – When paving super elevated slabs, bridge decks or skewed decks both rollers must be turning in the same direction and the Automatic Roller Reversing Valve should be set in the "Non-Reversing" position. The concrete should be pushed from the low side to the high side of the elevation and roll over the concrete going down the super elevation (See figure, p. 30)

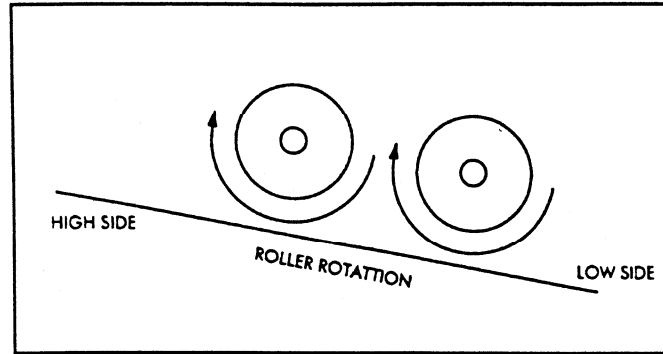

The roller direction will depend on the direction of the pour and what side is the high side.

**PAVING UP & DOWN GRADES** – When paving up a grade, the rear of the paving rollers may need to be raised higher (approximately 1/8" to 1/4"). Raise the back of the machine 1/8 of an inch by turning the leg crank 1/2 turn counterclockwise. The augers may need to be adjusted lower. Adjusting the augers with the Auger Adjusting Crank (Handle). These adjustments will counteract the tendency of excess concrete from moving downhill toward the paving rollers. When paving down a grade, the augers may need to be raised higher to provide the proper amount of concrete to the paving rollers. The rear of the paving rollers may not need to be raised but be sure that there is close to total contact with the deck or slab. When paving down hill, you want maximum surface contact with the concrete but not allow any ridge or line of concrete to come off the rear of the paving rollers.

**PAVING CURVES** – Given the known length or distance of the inside and outside curve, mark an equal number of spaces on the inner curve (1 to 2 feet in length). Count the number of spaces on the inner curve and mark the same number of spaces on the outer curve. The length of these spaces will vary with the length of the outer curve section (See figure below).

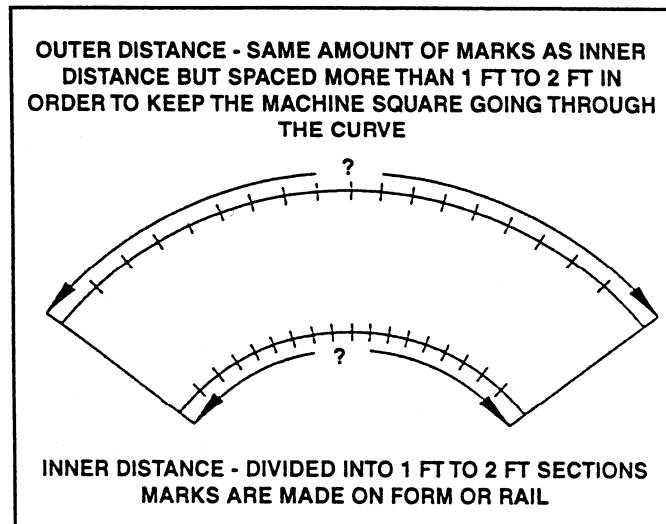

To negotiate the inner curve, the operator will at times place the Machine Direction Control Lever in the neutral position allowing a longer amount of travel for the outer curve and the machine. Keep the front wheels of both the inner and outer ends aligned with the marks placed on the rail or curb.

**MACHINE ADVANCEMENT** – The advancement of the machine at the end of each pass is based on the rate of concrete being poured. The operator should pace the machine advancement so that the physical placement of the concrete is no more than 6 to 8 feet in front of the machine. Normal advancement of the machine will vary from 3 to 6 inches (up to 12 inches) for each carriage pass. This will insure that fresh concrete will move into the paving rollers before dehydration of the concrete occurs. This is particularly true in hot, windy weather. The decking and sub-base material should also be kept wet in hot, windy weather to aid in the slowing down of the drying process.

**CARRIAGE TRAVEL SPEED** – At times it may be advantageous to slow down the carriage travel speed. Slowing the carriage travel will allow the paving rollers to have longer contact with the surface. Slowing the carriage travel speed may be beneficial when paving Super Plasticized Concrete or Latex Modified concrete. The carriage speed can be reduced by slowing down the engine or by using the carriage speed control located on the operator's console. The operating speed of the engine should run 2800 to 3200 RPM. At these speeds the carriage will travel approximately 85 to 90 feet per minute transversely across the machine.