

**CONSTRUCTION INSPECTOR'S CHECKLIST  
FOR  
PIPE CULVERTS**

This checklist has been prepared to provide the field inspector a summary of easy-to-read step-by-step requirements relative to the proper installation of Pipe Culverts (Section 542). The following questions are based on information found in the Standard Specifications, Construction Manual and current policy memorandum and letters.

Have you checked the Special Provisions, Supplemental Specifications and plans to see if any modifications have been made to the requirements listed herein? \_\_\_\_\_

**1. LENGTH COMPUTATION**

Are you, as a matter of routine before staking the pipe, calculating the needed length based upon shoulder and ditch elevations? \_\_\_\_\_

If your calculation differs from the plan length, inform your supervisor so that the correction can be made.

Are you transferring your left and right of centerline length calculation to the culvert field book so that it can be staked correctly? \_\_\_\_\_

**2. FIELD STAKING**

a. Are you checking with the Contractor to see what offsets and spacings are needed? \_\_\_\_\_

b. Are you taking elevation shots in the existing channel on each end for several hundred feet (meters) to make sure the proposed pipe will fit field conditions? \_\_\_\_\_

c. Are you staking the ends of the pipe to determine whether the alignment shown on the plans will fit the channel? \_\_\_\_\_

d. If the plan line or grade of the pipe does not fit field conditions, are you contacting your supervisor so that the appropriate changes can be made? \_\_\_\_\_

**3. INSPECTION OF DELIVERED PIPE SECTIONS**

a. Are you visually inspecting each section of delivered pipe for defects? \_\_\_\_\_

NOTE: Concrete pipe sections are subject to rejection for the following reasons:

- (1) Broken bells and spigots \_\_\_\_\_
- (2) Fractures or cracks passing through the walls or joints or those sufficient to impair strength, durability or serviceability of the product \_\_\_\_\_
- (3) Insufficient cover of concrete over steel (ghosting) \_\_\_\_\_
- (4) Defects that indicate imperfect proportioning, mixing and molding; i.e. honeycomb, patching, etc. \_\_\_\_\_
- (5) Insecure attachment of branches or spurs. \_\_\_\_\_

**4. PIPE MARKINGS**

Have you checked the plans to see if a particular kind of material is specified for the installation? \_\_\_\_\_

Have you checked the plans to determine the pipe "class" and "type" so that the pipe strength and material alternatives (when the material is not specified) can be chosen from Tables IA, IB, IC, IIA, IIB, IIIA, IIIB, or IIIC, Article 542.03? \_\_\_\_\_

Do the delivered pipe sections have markings which correspond with the kinds of materials permitted by the Table? \_\_\_\_\_

Required pipe markings:

a. Reinforced Concrete Culvert, Storm Drain and Sewer Pipe (AASHTO M170)

Reinforced Concrete Elliptical Culvert, Storm Drain and Sewer Pipe (AASHTO M207)

Reinforced Concrete Arch Culvert, Storm Drain and Sewer Pipe (AASHTO M206)

- (1) Pipe class and specification designation:
  - (a) Circular = I through V
  - (b) Horizontal Elliptical = HE – I through IV
  - (c) Arch = A – II through IV
- (2) Date of manufacture
- (3) Name or trademark of the manufacturer
- (4) Identification of plant

- b. Concrete Sewer, Storm Drain, and Culvert Pipe (AASHTO M86)
  - (1) Pipe class and specification designation
    - (a) Class III
  - (2) Date of manufacture
  - (3) Name or trademark of the manufacturer
  - (4) Identification of plant
  
- c. Extra Strength Clay Pipe (ASTM C700)  
Clay Sewer Pipe (ASTM C700)
  - (1) Initials or name of manufacturer
  - (2) Location of plant
  - (3) Words "Extra Strength" or the symbol "ES" when applicable
  
- d. Corrugated Steel Culvert Pipe (AASHTO M36, M218)  
Corrugated Steel Pipe Arch (AASHTO M36, M218)  
Bituminous Coated Corrugated Steel Culvert Pipe (AASHTO M36, M218, M190 Type A)  
Bituminous Coated Corrugated Steel Pipe Arch (AASHTO M36, M218, M190 Type A)  
Aluminized Steel Type 2 Corrugated Culvert Pipe (AASHTO M36, M274)  
Aluminized Steel Type 2 Corrugated Pipe Arch (AASHTO M36, M274)
  - (1) Name of manufacturer
  - (2) Brand name
  - (3) Specified thickness
  - (4) Specified coating mass
  - (5) Identification symbols relating to a specific heat number and coating lot number
  - (6) AASHTO or ASTM designation number
  
- e. Zinc and Aramid Fiber Composite Coated Corrugated Steel Pipe (AASHTO M36, ASTM A885)
  - (1) Name of manufacturer
  - (2) Brand name
  - (3) Specified thickness
  - (4) Identification symbols relating to a specific heat number and coating lot number
  - (5) ASTM designation number

## f. Pre-Coated Galvanized Corrugated Steel Culvert Pipe (AASHTO M245, M246)

## Pre-Coated Galvanized Corrugated Steel Pipe Arch (AASHTO M245, M246)

- (1) Name of sheet provider
- (2) Brand name
- (3) Specified thickness of metallic-coated sheet
- (4) Type of metallic coating (only galvanized)
- (5) Type or thickness of polymer coating
- (6) Identification symbols relating to a specific heat number and coating lot number
- (7) AASHTO or ASTM designation number

## g. Corrugated Aluminum Alloy Pipe (AASHTO M196)

## Corrugated Aluminum Alloy Culvert Pipe Arch (AASHTO M196)

- (1) Name of sheet manufacturer
- (2) Identification of the pipe fabricator, if different than the sheet manufacturer
- (3) Alloy and temper
- (4) Specified thickness
- (5) Processing date or lot number
- (6) AASHTO or ASTM designation number

## h. Polyvinyl Chloride (PVC) Pipe – 10”, 12”, 15” nominal diameter (AASHTO M278 or ASTM F679)

- (1) Manufacturer’s name or trademark
- (2) Nominal size
- (3) Specification designation M278
- (4) Plant designation code

## i. Polyvinyl Chloride (PVC) Pipe – 18” through 36” nominal diameter (AASHTO M278 or ASTM F679)

- (1) Manufacturer’s name or trademark and code
- (2) Nominal pipe size
- (3) Minimum cell classification
- (4) Pipe stiffness designation: PS 46 PVC Sewer Pipe
- (5) Specification designation ASTM F679

- j. Corrugated Polyvinyl Chloride (PVC) Pipe with a Smooth Interior (ASTM F949)
  - (1) Manufacturer's name, trade name or trademark
  - (2) Nominal pipe size
  - (3) PVC and minimum cell classification
  - (4) Extrusion code
  - (5) Specification designation ASTM F949
  
- k. Polyvinyl Chloride (PVC) Profile Wall Pipe – 794 (ASTM F794)
  - (1) Manufacturer's name, trade name or trademark, and code
  - (2) Nominal pipe size
  - (3) Minimum cell classification
  - (4) Legend "PS 46 PVC Sewer Pipe" or "PS 10 PVC Sewer Pipe"
  - (5) Specification designation ASTM F794
  
- l. Polyvinyl Chloride (PVC) Profile Wall Pipe – 304 (AASHTO M304)
  - (1) Manufacturer's name, trade name or trademark, and code
  - (2) Nominal pipe size
  - (3) Minimum cell classification
  - (4) Legend "Drain Pipe"
  - (5) Specification designation AASHTO M304
  
- m. Polyethylene (PE) Pipe with a Smooth Interior (ASTM F714)
  - (1) Specification designation ASTM F714
  - (2) PE followed by cell classification
  - (3) Nominal pipe outside diameter
  - (4) Dimensional ratio or pressure rating
  - (5) Name or trademark of the manufacturer
  - (6) Production code
  
- n. Polyethylene (PE) Profile Wall Pipe (ASTM F894)
  - (1) Specification designation ASTM F894
  - (2) Nominal pipe size
  - (3) PE sewer and drain pipe
  - (4) RSC classification
  - (5) Material designation
  - (6) Manufacturer's name, trade name or trademark
  - (7) Production code

- o. Corrugated Polyethylene (PE) Pipe with a Smooth Interior (AASHTO M294)
  - (1) Manufacturer’s name or trademark
  - (2) Nominal size
  - (3) Specification designation AASHTO M294
  - (4) Plant designation code
  - (5) Date of manufacturer or an appropriate code

**5. METHODS OF INSTALLATION**

Is the pipe being installed in conformance with one of the following methods:

- a. Method I - Unless otherwise specified, pipe culverts, except entrance culverts shall be installed in a trench by this method. (Art. 542.04) \_\_\_\_\_
- b. Method II - Used for extensions of existing culverts or inaccessible areas where a trench is impractical. It must be so noted on the plans or permitted in writing from the Engineer. (Art. 542.05). \_\_\_\_\_
- c. Method III - Used for the installation of entrance culverts. (Art. 542.06). \_\_\_\_\_

**6. METHOD I CONSTRUCTION (Art. 542.04)**

- a. Unsuitable Soil Removal and Replacement (Art. 542.04(a))

Prior to the construction of any necessary embankment preceding the trenching for the culvert work, is all unsuitable material present at the existing ground level being removed and replaced with suitable material in accordance with Article 202.03? \_\_\_\_\_

If, however, the unsuitable material is not discovered until after trenching has begun, is the removal and replacement being performed as follows:

Width of removal = ID + OD + ID

Depth of removal = As determined by the Engineer

Replacement material = Aggregate material placed in 8 inches (200 mm) layers, loose measurement and mechanically compacted to the satisfaction of the Engineer. \_\_\_\_\_

b. Rock Removal and Replacement (Art. 542.04(a))

If rock is encountered at locations along the line of the pipe, is it being removed and replaced as follows:

Width of removal:

- 9" + OD + 9" when ID ≤ 24"
- 12" + OD + 12" when ID > 24" to 48"
- 18" + OD + 18" when ID > 48"

- 225 mm + OD + 225 mm when ID ≤ 600 mm
- 300 mm + OD + 300 mm when ID > 600 mm to 1200 mm
- 450 mm + OD + 450 mm when ID > 1200 mm

Depth of removal = Greater of: 12 inches below pipe, or fill over pipe in feet x 1/2 inch/foot (300 mm below pipe, or fill over pipe in meters x 40 mm/m). Replacement material = Aggregate placed in 8" (200 mm) lifts, loose measurement and mechanically compacted to the satisfaction of the Engineer.

c. Pre-trenching Embankment (Art. 542.04(b))

If all or a portion of the pipe will be in fill, is an embankment being constructed prior to excavating the trench?

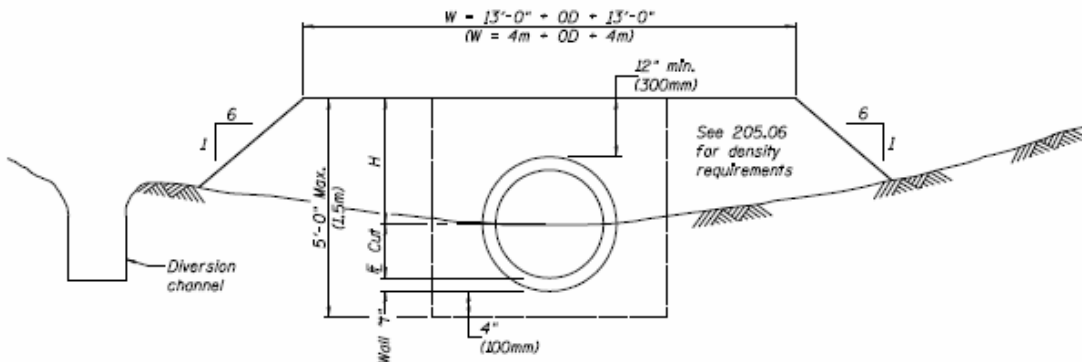

H will be the smaller of:  
 $H = 5 - (FL \text{ cut} + t + 4/12)$  or,  
 $H = (1.0 + OD + 4/12) - (FL \text{ cut} + t + 4/12)$   
 (all dimensions must be feet)

H will be the smaller of:  
 $H = 1.5 - (FL \text{ cut} + t + 0.1)$  or,  
 $H = (0.3 + OD + 0.1) - (FL \text{ cut} + t + 0.1)$   
 (all dimensions must be meters)

d. Trenching (Art. 542.04(b))

Is the Contractor excavating a vertical face trench which is no wider than:

W = 9" + OD + 9" when ID ≤ 24"

W = 12" + OD + 12" when ID > 24" to 48"

W = 18" + OD + 18" when ID > 48"

W = 225 mm + OD + 225 mm when ID ≤ 600 mm

W = 300 mm + OD + 300 mm when ID > 600 mm to 1200 mm

W = 450 mm + OD + 450 mm when ID > 1200 mm

Is the depth of the trench excavated to an elevation 4 inches (100 mm) below the bottom of the pipe?

e. Foundation Preparation (Art. 542.04(c))

Is at least 4 inches (100 mm) of aggregate mechanically compacted to the satisfaction of the Engineer being placed for the entire width of the trench and for the length of the pipe, except for the outer 3 feet (1 m) at each end of the pipe which is to be prepared with well compacted impervious material (clay)?

Are pipe bells being placed in small cross trenches shaped in the sand bedding material?

f. Pipe Installation (Art. 542.04(d))

Is the pipe being laid from the downstream end toward the upstream end with the pipe spigots pointing toward the outlet end of the trench?

Are the longitudinal laps of all metal pipe sections being placed at the sides?

g. Joints (Art. 542.04(d))

Are all joints in concrete pipe being completely filled and sealed with mastic joint filler (Art. 1055.01), preformed flexible gaskets (Art. 1056.01), or external sealing bands (Art. 1057.01)?

Are all sections being pushed or pulled into place to ensure tight joints?

Are all concrete sections having a diameter greater than 42 inches (1050 mm) being "brought home" with a winch, come-along or other positive means?

Are separate sections of metal pipe being joined with tightly drawn, approved connectors?

Are PVC pipes joined according to ASTM D3034?

h. Handling Holes (Art. 542.04(d))

Are all handling holes in concrete sections being filled with a tapered precast plug, sealed and covered with mastic or mortar?

\_\_\_\_\_

i. Elongation (Art. 542.04(e))

If Table IB or IC, specifies that circular corrugated steel or aluminum alloy pipe is to be elongated, is one of the three methods being used?

\_\_\_\_\_

j. Backfilling (Art. 542.04(f))

Is the entire length and width of the culvert trench (except 3 feet (1 m) at each end) being backfilled with aggregate placed in 8" (200 mm) lifts, loose measurement and compacted to the satisfaction of the Engineer by mechanical means to a height of at least the center of the pipe?

\_\_\_\_\_

If the Contractor is using flexible pipe, is the entire length and width of the culvert trench (except 3 feet (1 m) at each end) being backfilled with aggregate placed in 8 inch (200 mm) lifts, loose measurement and compacted to at least 85% density by mechanical means to a height of at least 1 foot (300 mm) above the pipe?

\_\_\_\_\_

Is remainder of the trench backfilled as follows?

(1) Are trenches made in the subgrade of the proposed improvement, and trenches where the inner edge of the trench is within 2 feet (600 mm) of the proposed edge of pavement, curb, gutter, curb and gutter, stabilized shoulder, or sidewalk the remainder of the trench shall be backfilled with trench backfill in accordance with section 208. The material shall be placed in lifts not exceeding 8 inches (200mm) in depth and compacted to 85% density?

\_\_\_\_\_

Is the outer 3 feet (1 m) at each end of the pipe trench being backfilled with well compacted impervious material?

\_\_\_\_\_

(2) Are all other trenches being backfilled with select material in 8" (200 mm) lifts, loose measurement and compacted to 95% density within 80 to 110% optimum moisture content by mechanical means? The Contractor has the option to use aggregate instead of select material at no additional cost to the contract. It shall be compacted to the satisfaction of the Engineer by mechanical means.

\_\_\_\_\_

k. Embankment (Art. 542.04(g))

If the top of the trench is not 12" (300 mm) over the top of the pipe, is embankment constructed to 12" (300 mm) over the top of the pipe? \_\_\_\_\_

(1) Is the embankment being placed in 8" (200 mm) lifts loose measurement and compacted? \_\_\_\_\_

(2) Is the density in accordance with Section 205 of the Standard Specifications, Embankment? \_\_\_\_\_

(3) Is the configuration of the embankment the same as Item 6(c)? \_\_\_\_\_

(4) Is heavy earth moving equipment not permitted within 4 feet (1.2 m) of either side of the pipe culvert? \_\_\_\_\_

l. Are all PVC and PE pipe culverts being tested for deflection not less than 30 days after the backfill is compacted? (Art. 542.04(i)) \_\_\_\_\_

7. **METHOD II CONSTRUCTION (Art. 542.05)**

Are all specified Method II pipes being installed as follows:

a. Site Preparation

Is the existing ground along the length of the pipe at least one-tenth of the diameter higher than the bottom of the pipe? If not, it will be necessary to fill a small amount in the low areas to reach this elevation. \_\_\_\_\_

b. General Requirements

Are the construction methods of Method I for all construction below this elevation being used? (e.g. Unsuitable soil removal and replacement, Rock removal and replacement, Trenching, Foundation preparation, Pipe installation and backfilling to natural ground.) \_\_\_\_\_

c. Embankment

After the backfilling is performed up to the level of the existing ground, is embankment being constructed to 1 foot (300 mm) above the top of the pipe as follows:

(1) The embankment placed in 8" (200 mm) lifts loose measurement and compacted? \_\_\_\_\_

(2) The backfill up to the center of the pipe and 18" (450 mm) on either side composed of aggregate? \_\_\_\_\_

(3) The outer 3 feet (1 m) of each end of the pipe composed of impervious material backfill? \_\_\_\_\_

(4) The backfill material above the center of the pipe composed of select material? \_\_\_\_\_

(5) Is heavy earth moving equipment not allowed within 4 feet (1.2 m) of either side of the pipe. (Only hand mechanical compaction equipment allowed.) \_\_\_\_\_

Does the completed embankment around the Method II pipe conform to the same cross-section as specified in Method I? \_\_\_\_\_

**8. ADDITIONAL EMBANKMENT (Art. 542.04(h))**

If heavy loads will be running over the completed pipe embankment, is additional embankment as specified in Table IV being constructed first? \_\_\_\_\_

**9. METHOD III CONSTRUCTION (Art. 542.06)**

Are all entrance culverts being installed with the following requirements:

- a. Is a trench depth of at least the external pipe diameter/10 being excavated? (Art. 542.06(a)) \_\_\_\_\_
- b. Is the trench being excavated only to the bottom of the pipe and to a width necessary to place the pipe? (Art. 542.06(a)) \_\_\_\_\_
- c. After the removal and replacement of any unsuitable material or rock, is the trench being shaped to fit the exterior of the pipe? (Art. 542.06(b)) \_\_\_\_\_
- d. After the placing of the pipe as specified in Method I (Art. 542.04(d)), is select backfill being placed in 8" (200 mm) layers, loose measure and compacted by mechanical means to the satisfaction of the Engineer? (Art. 542.06(d)) \_\_\_\_\_
- e. Is the backfill material placed to at least 1 foot (300 mm) over the top of the pipe or to the finished grade, whichever is the lesser? (Art. 542.06(d)) \_\_\_\_\_

**10. END TREATMENT (Art. 542.07)**

If end treatment is required and the pipe is at 15 degree skew or less with the roadway and the diameter is 84" (2100 mm) or less, unless otherwise specified, are you allowing the Contractor the option of using a cast-in-place Class SI Concrete headwall or a prefabricated end section of either precast reinforced concrete or metal? \_\_\_\_\_

NOTE: If a prefabricated end section is used, it shall be of the same material as the pipe (concrete-concrete, steel-steel, aluminum-aluminum). A metal end section shall be used with PVC or PE pipe.

**11. DOCUMENTATION OF FINAL QUANTITIES**

PIPE CULVERTS - lin. ft. (lin. meter)

In-place field measurements, each run measured to the nearest 0.1 foot (meter). (Guide for Documentation)

The pay length cannot exceed the length shown on the plans or authorized in writing by the Engineer. (Art. 542.10)

If the contract does not contain unit prices for the removal and replacement of unstable or unsuitable material or rock, this work will be paid for as provided in Article 109.04. Documentation for all extra work performed in accordance with Article 109.04(b) should be recorded on Form [BC 635](#), Extra Work Daily Report.

- END SECTIONS - Each
- PRECAST REINFORCED CONCRETE FLARED END SECTION - Each
- STEEL END SECTIONS - Each
- ALUMINUM END SECTIONS - Each
- METAL END SECTIONS - Each
- CAST-IN-PLACE REINFORCED CONCRETE END SECTIONS - Each

Revised to conform with the  
Standard Specifications for Road and Bridge Construction  
Adopted January 1, 2007