

**CONSTRUCTION INSPECTOR'S CHECKLIST
FOR
STORM SEWERS**

This checklist has been prepared to provide the field inspector a summary of easy-to-read step-by-step requirements relative to the proper installation of Storm Sewers (Section 550 of the Standard Specifications). The following questions are based on and referenced to information found in the Standard and Supplemental Specifications, Highway Standards and appropriate sections of the Construction Manual.

1. FIELD STAKING

As you stake the pipe:

- a. Are you checking with the Contractor to see what offset and spacings are needed in the stakes? _____
- b. Are you checking the inlet and outlet flow line elevations to make sure they will meet existing or proposed appurtenance grades? _____
- c. Are you checking the horizontal alignment to make sure it satisfies the field conditions? (The pipe must be placed in a straight line between appurtenances.) _____
- d. If water mains not shown on the plans or not located as shown on the plans are encountered, have you checked local ordinances or EPA requirements for protection by horizontal or vertical separation or protection by special material and joints? _____

2. INSPECTION OF DELIVERED PIPE SECTIONS

- a. Are you visually inspecting each section of delivered pipe for defects? _____

Note: Concrete pipe sections are subject to rejection for the following reasons:

- (1) Broken bells and spigots _____
- (2) Fractures or cracks passing through the walls or joints or those sufficient to impair strength, durability or serviceability of the product _____
- (3) Insufficient cover of concrete over steel (ghosting) _____
- (4) Defects that indicate imperfect proportioning, mixing and molding; i.e. honeycomb, patching, etc. _____
- (5) Insecure attachment of branches or spurs. _____

3. PIPE MARKINGS

Have you checked the plans to see if a particular kind of material is specified for the installation? _____

Have you checked the plans to determine the storm sewer "class" and "type" so that alternate materials and strengths (when the material is not specified) can be chosen from the Tables in Article 550.03? _____

Have you checked the delivered pipe to make certain the pipe markings correspond with the kinds of materials permitted by Article 550.03 and the table? _____

Required pipe markings:

a. Reinforced Concrete Culvert, Storm Drain and Sewer Pipe (AASHTO M170)

Reinforced Concrete Elliptical Culvert, Storm Drain and Sewer Pipe (AASHTO M207)

Reinforced Concrete Arch Culvert, Storm Drain and Sewer Pipe (AASHTO M206)

- (1) Pipe class and specification designation:
 - (a) Circular = I through V
 - (b) Arch = A – II through IV
 - (c) Elliptical = HEA, HE - I through IV
VE - II through VI

- (2) Date of manufacture
- (3) Name or trademark of the manufacturer
- (4) Identification of plant

b. Concrete Sewer, Storm Drain, and Sewer Pipe (AASHTO M86)

- (1) Pipe class and specification designation Class
 - (a) Class: I through III

- (2) Date of manufacture
- (3) Name or trademark of the manufacturer
- (4) Identification of plant

c. Polyvinyl Chloride (PVC) Pipe – 10”, 12”, 15” nominal diameter (AASHTO M278)

- (1) Manufacturer’s name or trademark
- (2) Nominal size
- (3) Specification designation M278
- (4) Plant designation code

d. Polyvinyl Chloride (PVC) Pipe – 18” through 36” nominal diameter (ASTM F679)

- (1) Manufacturer’s name or trademark and code
- (2) Nominal pipe size
- (3) Minimum cell classification
- (4) Pipe stiffness designation: PS 46 PVC Sewer Pipe
- (5) Specification designation ASTM F679

e. Corrugated Polyvinyl Chloride (PVC) Pipe with a Smooth Interior (ASTM F949)

- (1) Manufacturer’s name, trade name or trademark
- (2) Nominal pipe size
- (3) PVC and minimum cell classification
- (4) Extrusion code
- (5) Specification designation ASTM F949

f. Polyvinyl Chloride (PVC) Profile Wall Pipe – 794 (ASTM F794)

- (1) Manufacturer’s name, trade name or trademark, and code
- (2) Nominal pipe size
- (3) Minimum cell classification
- (4) Legend “PS 46 PVC Sewer Pipe” or “PS 10 PVC Sewer Pipe”
- (5) Specification designation ASTM F794

g. Extra Strength Clay Pipe (ASTM C700)

Clay Sewer Pipe (ASTM C700)

- (1) Initials or name of manufacturer
- (2) Location of plant
- (3) Words “Extra Strength” or the symbol “ES” when applicable

4. UNSUITABLE SOIL REMOVAL AND REPLACEMENT

If soft, spongy or other unsuitable soil is encountered at pipe grade, is all such unsuitable soil being removed for the width of the trench and replaced with well compacted aggregate? (Art. 550.04) _____

Is the removal and replacement of unsuitable material below plan bedding grade being paid for in accordance with Article 109.04? (Art. 550.10) _____

5. TRENCH EXCAVATION (Art. 550.04)

CASE I

(When trench depth $\leq 5'$ (1.5m) and when sheeting or shoring is not required):

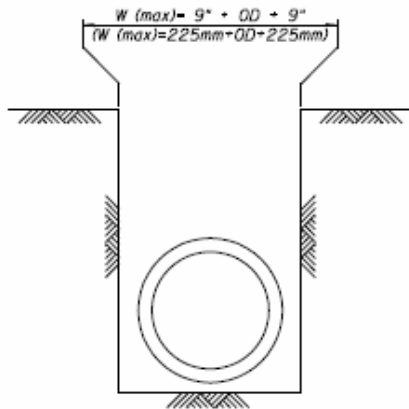

CASE II

(When trench depth $> 5'$ (1.5m) or when sheeting or shoring is required):

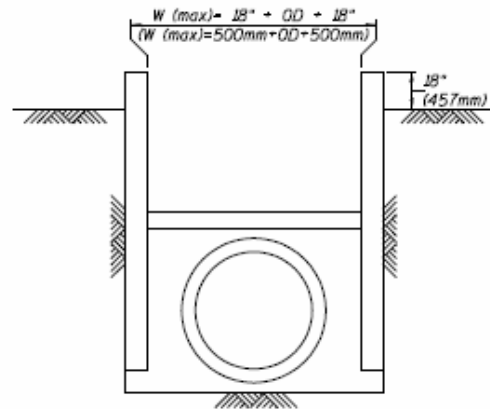

Is the trench being excavated so that vertical faces are maintained at least to the elevation of the top of pipe? _____

For trench depths greater than 5 feet (1.5 m), the Contractor shall provide trench protection according to the applicable standards for work place safety. Is the Contractor providing to the Engineer, in writing, his/her procedures for fulfilling the safety requirements for trench protection? _____

6. OPTIONAL TRENCH CONFIGURATIONS

(When trench depth > 5 feet (1.5m) (Art. 550.04)

Optional trench configurations shall be constructed in accordance with OSHA requirements contained in the Code of Federal Regulations Labor 29 Part 1926 Subpart P - Excavations.

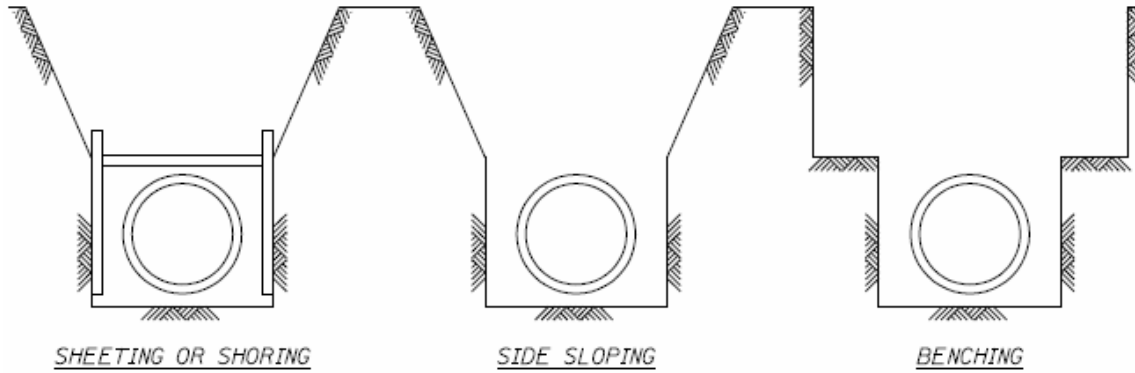

7. ROCK REMOVAL AND REPLACEMENT (Art. 550.04)

If rock is encountered in the trench, is it being removed 8" (200 mm) below the bottom of the pipe grade and replaced with well-compacted aggregate?

Is the excavation of rock being paid for per cubic yard (meter) of ROCK EXCAVATION FOR STRUCTURES, or, if there is no such plan pay item, is it being paid for in accordance with Article 109.04?

8. TRENCH BED PREPARATION (Art. 550.04)

If the excavation has been made deeper than necessary, is only well compacted aggregate being used to bring the foundation back up to the proper grade?

Is at least 4 inches (100 mm) of well compacted aggregate being placed the entire width of the trench and for the length of the pipe, except when the storm sewer outlets from an embankment or natural ground, the last 3 feet (1m) of the pipe shall be bedded in impervious material?

9. PIPE INSTALLATION (Art. 550.06)

Is the contractor, at his/her own expense, keeping the trench free of water?

Is the pipe being laid from the downstream end towards the upstream end with the pipe spigots pointing toward the direction of flow?

Are pipe bells being placed in small cross trenches shaped in the sand bedding material? (Art. 550.04)

If the pipe outlets into an open ditch, is the flow line of the pipe at least 6 inches (150mm) above the flow line of the ditch?

10. JOINTS (Art. 550.06)

Are all joints in concrete sewer pipe being sealed with rubber gaskets, preformed flexible joint sealants, mastic joint sealer or external sealing bands?

When mastic joint sealer is being used, is the joint being completely filled and wiped clean on the inside after the pipes have been brought together? _____

Are PVC pipes joined according to ASTM D 3034? _____

Are all sections being pushed or pulled into place to ensure tight joints? _____

Are all pipes having a diameter greater than 42 inches (1050 mm) being "brought home" with a winch, come-a-long or other positive means? _____

11. HANDLING HOLES (Art. 550.06)

Are all lifting holes being filled with precast concrete plugs sealed and covered with mastic or mortar? _____

12. BACKFILL MATERIALS (Art. 550.07)

a. Does the backfill material from the trench bed up to the midpoint of the pipe consist of aggregate placed in 8 inch (200mm) lifts, loose measurement and compacted by mechanical means to the satisfaction of the Engineer? _____

If the Contractor is using PVC pipe, is the entire length and width of the trench being backfilled with aggregate placed in 8 inch (200 mm) lifts, loose measurement and compacted to at least 85% density to a height of at least 1 foot (300 mm) above the pipe? _____

b. Are all trenches which are made in the subgrade of the proposed improvement and all trenches where the inner edge of the trench is within 2 feet (600 mm) of the edge of the proposed pavement, curb, gutter, curb and gutter, stabilized shoulder or sidewalk being backfilled with the pay item TRENCH BACKFILL? _____

Note: The maximum pay limits for the volume of TRENCH BACKFILL shall not exceed the following:

Length = 2' + * + 2'
(600 mm + * + 600 mm)

* - Subgrade, Pavement, Curb, Gutter, Curb and Gutter, Stabilized Shoulder or Sidewalk

Depth = Midpoint of pipe to finished surface

Width = 9" + OD + 9" (when trench depth ≤ 5')
18" + OD + 18"(when trench depth > 5')

225 mm + OD + 225 mm (when trench depth ≤ 1.5 meters)

500 mm + OD + 500 mm (when trench depth > 1.5 meters)

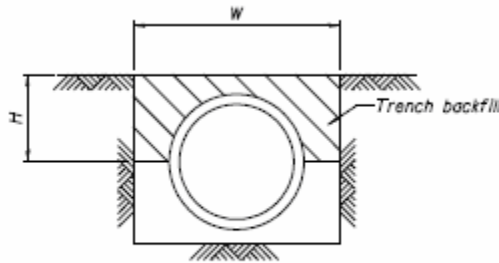

All dimensions in feet and divide by 27 for cubic yards.
(All dimensions in meters for cubic meters)

Volume = [(W x H) - (pipe area x 0.5)] x L

c. Are all other trenches which are excavated outside the limits specified for trench backfill being backfilled with the excavated materials? _____

13. BACKFILL COMPACTION REQUIREMENTS (Art. 550.07)

Is all backfill material above the first 12 inches (300 mm) for flexible (PVC) pipe and the springline of rigid pipe being compacted in accordance with one of the following optional methods:

Method 1 - The material shall be deposited in uniform layers not exceeding 12 inches (300 mm), loose measure and compacted with by mechanical means to the satisfaction of the Engineer.

When trench backfill is used the lifts shall not exceed 8 inches (200mm) in depth, loose measurements, and each lift shall be compacted to 85 percent of standard lab density by mechanical means. _____

Method 2 - The material shall be deposited in uniform layers not exceeding 12 inches (300 mm) thick, loose measure and each layer shall be either inundated or deposited in water.

When trench backfill is required, gradations CA 6 and CA 10 will not be allowed. _____

Method 3 - The trench shall be backfilled with loose material and settlement secured by introducing water through holes jetted into the backfill to a point approximately 2 feet (600 mm) above the top of the pipe. The holes should be spaced no further apart than 6 feet (2 m).

When trench backfill is required, gradations CA 6 and CA 10 will not be allowed.

14. INSTALLATION COMPLETION (Art. 550.07)

a. If water was used to compact the backfill, is it being allowed to settle and dry for at least 10 days before surface course or pavement is constructed on it? _____

At the end of the settling and drying period, are all depressions being filled with sufficient backfill material as specified in Method 1? _____

If the excavation was made across earth shoulders or private property, is all disturbed top soil being replaced and the whole area left in a neat and presentable condition? _____

15. DEFLECTION TESTING (Art. 550.08)

Are all PVC storm sewers being tested for deflection not less than 30 days after the backfill is completed? _____

16. DOCUMENTATION OF FINAL QUANTITIES

STORM SEWER - Lineal feet (meters):

In-place measurements, each run measured to the nearest 0.1 foot (meter). _____

TRENCH BACKFILL - Cubic yards (meters):

- a. [BC 981](#) (Plan quantity acceptance); or _____
- b. Trench measurements and calculations; or _____
- c. Trench measurements and standard tables. _____

Revised to conform with the
Standard Specifications for Road and Bridge Construction
Adopted January 1, 2007