

Chapter Thirty-three  
VERTICAL ALIGNMENT

BUREAU OF DESIGN AND ENVIRONMENT MANUAL



**Chapter Thirty-three**  
**VERTICAL ALIGNMENT**

**Table of Contents**

<b><u>Section</u></b>	<b><u>Page</u></b>
33-1 DEFINITIONS .....	33-1.1
33-2 GRADES .....	33-2.1
33-2.01 Terrain .....	33-2.1
33-2.02 Maximum Grades .....	33-2.1
33-2.03 Minimum Grades .....	33-2.1
33-2.04 Critical Length of Grade.....	33-2.2
33-3 TRUCK-CLIMBING LANES .....	33-3.1
33-3.01 Warrants .....	33-3.1
33-3.01(a) Two-Lane Highways .....	33-3.1
33-3.01(b) Multilane Highways .....	33-3.1
33-3.02 Capacity Analysis .....	33-3.2
33-3.03 Design Guidelines .....	33-3.2
33-3.04 Downgrades .....	33-3.6
33-3.05 Truck Speed Profile .....	33-3.6
33-4 VERTICAL CURVES.....	33-4.1
33-4.01 Crest Vertical Curves.....	33-4.1
33-4.01(a) Stopping Sight Distance.....	33-4.1
33-4.01(b) Decision Sight Distance .....	33-4.2
33-4.01(c) Passing Sight Distance .....	33-4.2
33-4.01(d) Drainage .....	33-4.7
33-4.02 Sag Vertical Curves.....	33-4.6
33-4.02(a) Stopping Sight Distance.....	33-4.8
33-4.02(b) Decision Sight Distance .....	33-4.11
33-4.02(c) Comfort Criteria.....	33-4.11
33-4.02(d) Underpasses .....	33-4.11
33-4.02(e) Drainage .....	33-4.13
33-4.03 Vertical Curve Computations.....	33-4.13
33-5 VERTICAL CLEARANCES .....	33-5.1

**Table of Contents**

(Continued)

<b><u>Section</u></b>	<b><u>Page</u></b>
33-6 DESIGN PRINCIPLES AND PROCEDURES .....	33-6.1
33-6.01 General Controls for Vertical Alignment .....	33-6.1
33-6.02 Coordination of Horizontal and Vertical Alignment .....	33-6.2
33-6.03 Aesthetics .....	33-6.8
33-6.03(a) General .....	33-6.9
33-6.03(b) Rural Visual Impacts .....	33-6.9
33-6.03(c) Urban Visual Impacts .....	33-6.14
33-6.04 Design of Profile Gradelines .....	33-6.17
33-6.04(a) General .....	33-6.17
33-6.04(b) Design of Urban Profile Gradelines .....	33-6.18
33-6.04(c) Design of Rural Profile Gradelines .....	33-6.19
33-6.04(d) Soils .....	33-6.19
33-6.04(e) Drainage/Snow .....	33-6.21
33-6.04(f) Erosion Control .....	33-6.22
33-6.04(g) Earthwork Balance .....	33-6.22
33-6.04(h) Bridges .....	33-6.23
33-6.04(i) At-Grade Railroad Crossings .....	33-6.24
33-6.04(j) Distance Between Vertical Curves .....	33-6.24
33-6.04(k) Ties With Existing Highways .....	33-6.24
33-7 REFERENCES .....	33-7.1

## Chapter Thirty-three

# VERTICAL ALIGNMENT

The vertical alignment contributes significantly to a highway's safety, aesthetics, operations, and costs. Long, gentle vertical curves provide greater sight distances and a more pleasing appearance for the driver. Chapters 43 through 50 provide numerical criteria for various vertical alignment elements based on highway functional class, project scope of work, and urban/rural location. Chapter 33 provides additional guidance on these and other vertical alignment elements, including maximum and minimum grades, critical lengths of grade, truck-climbing lanes, vertical curvature, vertical clearances, aesthetics, and developing a profile gradeline.

### 33-1 DEFINITIONS

1. Broken-Back Curves. A gradeline with two vertical curves in the same direction separated by a short section of tangent grade.
2. Bus. A heavy vehicle involved in the transport of passengers on a for-hire, charter, or franchised transit basis. Also, can be called a motor coach in rural areas.
3. Critical Length of Grade. The maximum length of a specific upgrade on which a loaded truck can operate without an unreasonable reduction in speed.
4. Grade Slopes. The rate of slope expressed as a percent between two adjacent VPI's. The numerical value for the grade is the vertical rise or fall in feet (meters) for each foot (meter) of horizontal distance. The numerical value is multiplied by 100 and is expressed as a percent. Upgrades in the direction of stationing are identified as plus (+). Downgrades are identified as minus (-).
5. Heavy Vehicles. Any vehicle with more than four wheels touching the pavement during normal operation. Heavy vehicles collectively include trucks, recreational vehicles, and buses.
6. K-Values. The horizontal distance needed to produce a 1% change in gradient.
7. Level Terrain. Level terrain generally is considered to be flat and has minimal impact on vehicular performance. Highway sight distances are either long or could be made long without major construction expense.
8. Momentum Grade. A site where an upgrade is preceded by a downgrade. These locations may allow a truck to increase its speed on the downgrade before ascending the upgrade.
9. Performance Curves. A set of curves which illustrate the effect grades will have on the design vehicle's acceleration and/or deceleration.

10. Profile Gradeline. A series of tangent lines connected by vertical curves. Typically, the gradeline is located along the roadway centerline of undivided multilane facilities and two-lane, two-way highways. For divided highways, it is typically located at the median edge of the traveled way for each roadway.
11. Recreational Vehicle. A heavy vehicle, generally operated by a private motorist, engaged in the transportation of recreational equipment or facilities; examples include campers, boat trailers, motorcycle trailers, etc.
12. Rolling Terrain. The natural slopes consistently rise above and fall below the roadway gradeline and, occasionally, steep grades present some restriction to the desirable horizontal and vertical alignment. In general, rolling terrain generates steeper grades causing trucks to reduce speeds below those of passenger cars.
13. Rugged Terrain. Longitudinal and transverse changes in elevation are abrupt, and benching and side hill excavation are usually required to provide the desirable horizontal and vertical alignment. Rugged terrain aggravates the performance of trucks relative to passenger cars and results in some trucks operating at crawl speeds.
14. Truck. A heavy vehicle engaged primarily in the transport of goods and materials or in the delivery of services other than public transportation. For geometric design and capacity analyses, trucks are defined as vehicles with six or more tires. Trucks may be defined as either single units (SU) or multiple units (MU). Data on trucks is compiled and reported by the district with assistance from the Office of Planning and Programming.
15. VPC (Vertical Point of Curvature). The point at which a tangent grade ends and the vertical curve begins.
16. VPI (Vertical Point of Intersection). The point where the extension of two tangent grades intersect.
17. VPT (Vertical Point of Tangency). The point at which the vertical curve ends and the tangent grade begins.

## 33-2 GRADES

### 33-2.01 Terrain

The topography throughout most of Illinois is considered to be either level or rolling. However, the northwest corner of the State, southern Illinois, and bluff areas near major rivers may be considered rugged. In general, if the terrain designation is not clear (e.g., level versus rolling), select the flatter of the two terrains. Where a multilane divided highway is proposed in rugged terrain, independent alignments with separate profiles are recommended.

### 33-2.02 Maximum Grades

Chapters 44 through 50 present Department criteria for maximum grades based on functional classification, urban/rural location, type of terrain, design speed, and project scope of work. Only use the maximum grades where it is absolutely necessary. Wherever practical, use grades flatter than the maximum.

### 33-2.03 Minimum Grades

The following provides the Department's criteria for minimum grades:

1. Uncurbed Roadways. It is desirable to provide a minimum longitudinal gradient of approximately 0.5%. This allows for the possibility of alterations to the original pavement cross slope due to swell, consolidation, maintenance operations, or resurfacing. Longitudinal gradients of approximately 0% may be acceptable on some pavements that have adequate cross slopes. These locations typically occur where a highway traverses a wide flood plain. In these cases, check the flow lines of the outside ditches for adequate drainage.
2. Curbed Streets. The median edge or centerline profile of streets with curb and gutter desirably should have a minimum longitudinal gradient of 0.5%. Where the adjacent development or flatter terrain precludes the use of a profile with a 0.5% grade, provide a minimum longitudinal gradient of at least 0.3%.

On curbed facilities, the longitudinal gradient at the gutter line will have a significant impact on the pavement drainage characteristics (e.g., water encroaching on traveled ways, flow captures rates by grates). See Chapter 40 of the *BDE Manual* and the *IDOT Drainage Manual* for more information on pavement drainage.

3. New Bridges. For bridges on new construction and reconstruction projects, provide a minimum longitudinal gradient of 0.5% across the bridge.

### 33-2.04 Critical Length of Grade

The critical length of grade is the maximum length of a specific upgrade on which a truck can operate without an unreasonable reduction in speed. The highway gradient in combination with the length of the grade will determine the truck speed reduction on upgrades. For additional guidance, see the *Highway Capacity Manual* and the AASHTO *A Policy on Geometric Design of Highways and Streets*.

The following will apply to the critical length of grade:

1. Design Vehicle. Figure 33-2.A presents the critical length of grade for a 200 lb/hp (120 kg/kW) truck. This vehicle applies to all truck routes in Illinois.

For additional guidance on truck routes, see Sections 36-1.08 and 43-5 and the latest IDOT Designated State Truck Route System Map.

2. Criteria. Figure 33-2.A provides the critical lengths of grade for a given percent grade and acceptable truck speed reduction. Although these figures are based on an initial truck speed of 70 mph (110 km/h), they apply to any design or posted speed. For design purposes, use the 10 mph (15 km/h) speed reduction curve in the figure to determine if the critical length of grade is exceeded.
3. Momentum Grades. Where an upgrade is preceded by a downgrade, trucks will often increase their speed to ascend the upgrade. A speed increase of 5 mph (10 km/h) on moderate downgrades (3%-5%) and 10 mph (15 km/h) on steeper downgrades (6%-8%) of sufficient length are reasonable adjustments to the initial speed. This assumption allows the use of a higher speed reduction curve in Figure 33-2.A. However, the designer should also consider that these speed increases may not always be attainable. If traffic volumes are sufficiently high, a truck may be behind another vehicle when descending the momentum grade thereby restricting the increase in speed. Therefore, only consider these increases in speed if the highway has a Level of Service C or better.
4. Measurement. Vertical curves are part of the length of grade. Figure 33-2.B illustrates how to measure the length of grade to determine the critical length of grade using Figure 33-2.A.
5. Application. If the critical length of grade is exceeded, flatten the grade, if practical, or evaluate the need for a truck-climbing lane; see Section 33-3. Typically, only two-lane highways have operational problems that require truck-climbing lanes.
6. Highway Types. The critical-length-of-grade criteria applies equally to two-lane or multilane highways and applies equally to urban and rural facilities.
7. Example Problems. Examples 33-2.1 and 33-2.2 illustrate the use of Figure 33-2.A to determine the critical length of grade. Example 33-2.3 illustrates the use of Figures 33-2.A and 33-2.B. In the examples, the use of subscripts 1, 2, etc., indicate the successive gradients and lengths of grade on the highway segment.

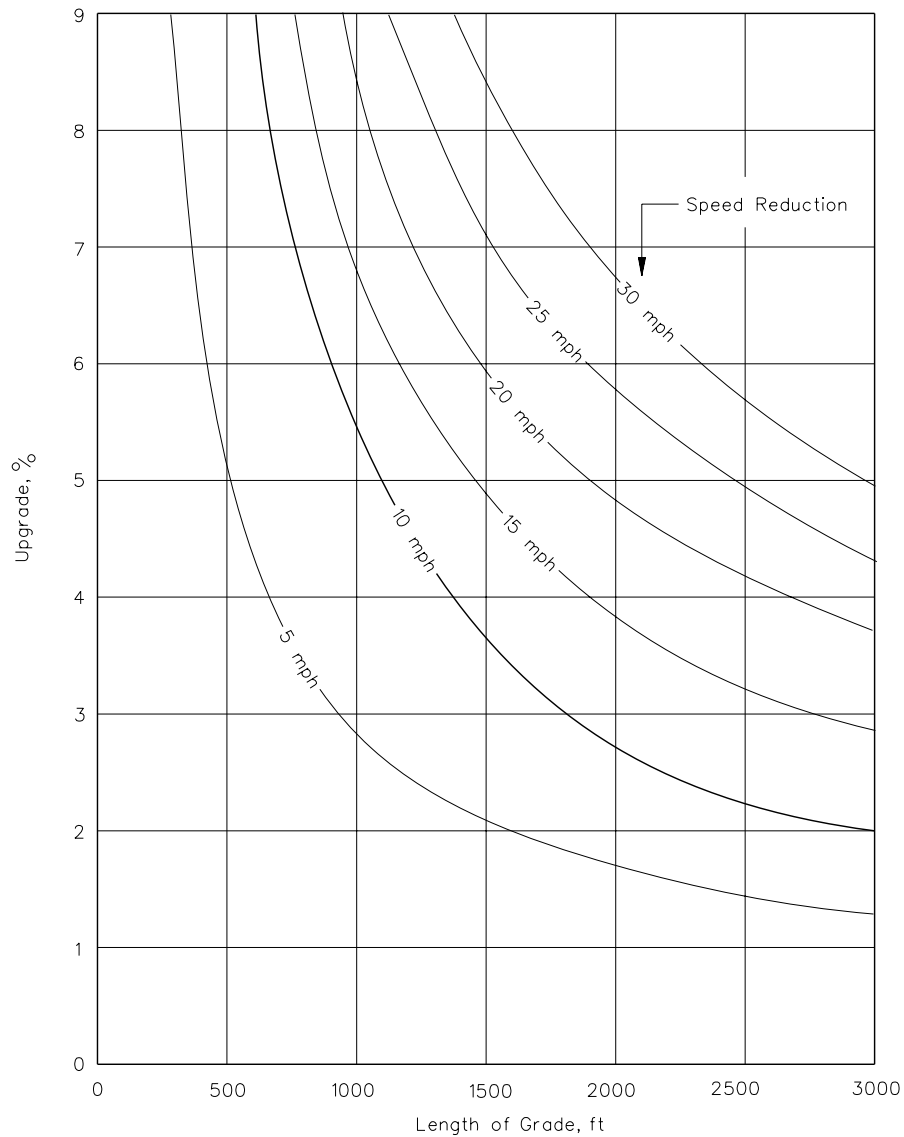

**Notes:**

1. Typically, the 10 mph curve will be used.
2. See examples in Section 33-2.04 for use of figure.
3. Figure is based on a truck with initial speed of 70 mph. However, it may be used for any design or posted speed.
4. This figure is based on a 200 lb/hp truck.

**CRITICAL LENGTH OF GRADE  
(US Customary)**

**Figure 33-2.A**

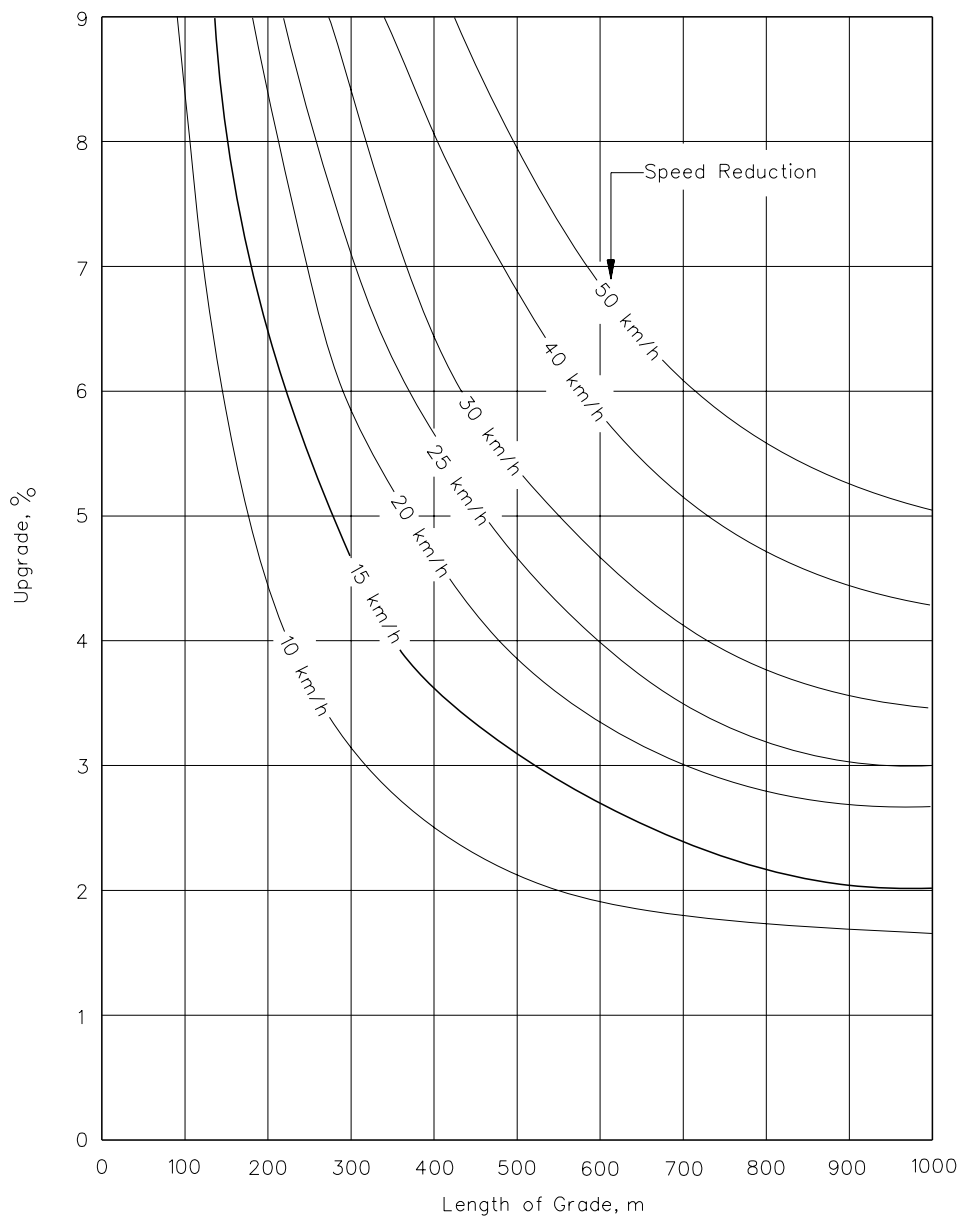

Notes:

1. Typically, the 15 km/h curve will be used.
2. See examples in Section 33-2.04 for use of figure.
3. Figure based on a truck with initial speed of 110 km/h. However, it may be used for any design or posted speed.
4. This figure is based on a 120 kg/kW truck.

**CRITICAL LENGTH OF GRADE  
(Metric)**

**Figure 33-2.A**

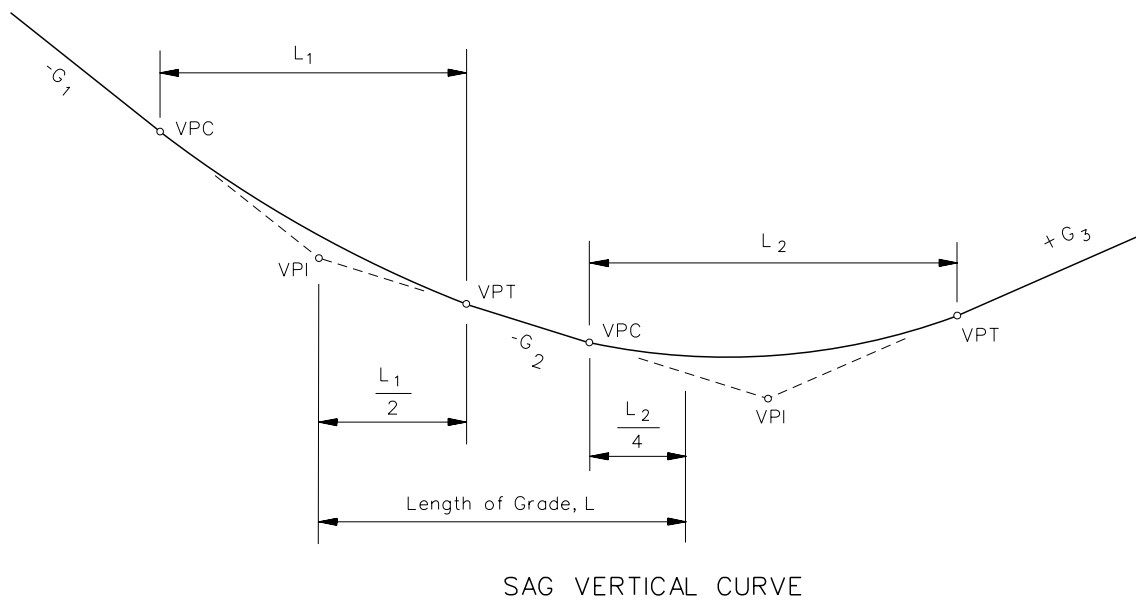
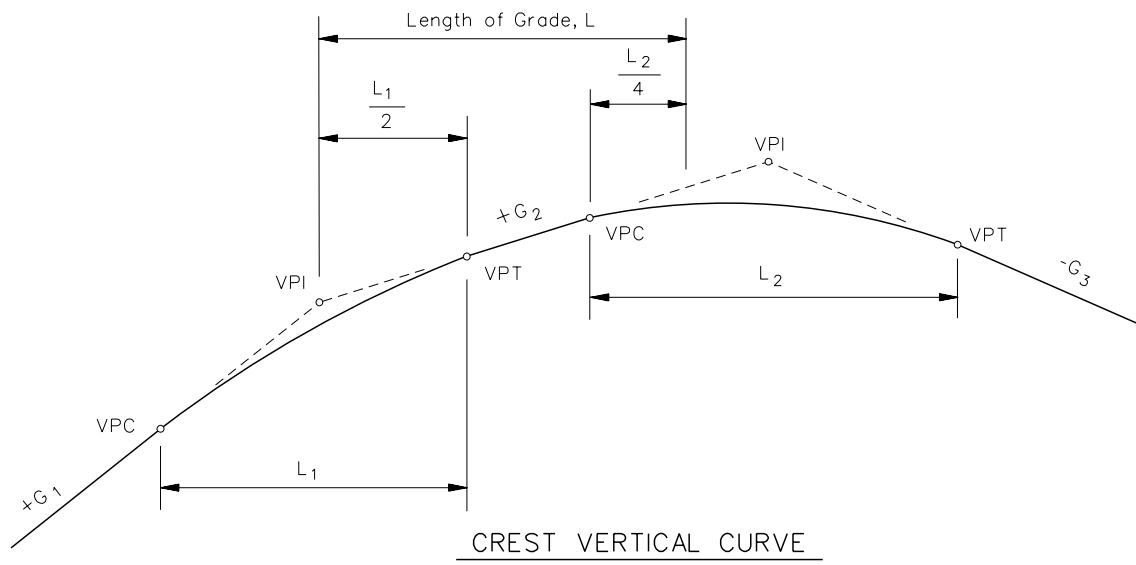
**Notes:**

1. For vertical curves where the two tangent grades are in the same direction (both upgrades or both downgrades), 50% of the curve length will be part of the length of grade.
2. For vertical curves where the two tangent grades are in opposite directions (one grade up and one grade down), 25% of the curve length will be part of the length of grade.
3. The above diagram is included for illustrative purposes only. Broken back vertical curves are to be avoided where practical. Distances less than 1500 ft (500 m) between VPI's are considered to be broken back.

**MEASUREMENT FOR LENGTH OF GRADE****Figure 33-2.B**

\* \* \* \* \*

### **Example 33-2.1**

**Given:** Level Approach  
G = +4%  
L = 1500 ft (length of grade)  
Rural Principal Arterial (Class II Truck Route)

**Problem:** Determine if the critical length of grade is exceeded.

**Solution:** For a Class II Truck Route, Figure 33-2.A yields a critical length of grade of 1200 ft for a 10-mph speed reduction. The length of grade (L) exceeds this value. Therefore, flatten the grade, if practical, or evaluate the need for a truck-climbing lane.

### **Example 33-2.2**

**Given:** Level Approach  
G<sub>1</sub> = +4.5%  
L<sub>1</sub> = 500 ft  
G<sub>2</sub> = +2%  
L<sub>2</sub> = 700 ft  
Marked Route Rural Collector with a significant number of heavy trucks

**Problem:** Determine if the critical length of grade is exceeded for the combination of grades G<sub>1</sub> and G<sub>2</sub>.

**Solution:** From Figure 33-2.A, G<sub>1</sub> yields a truck speed reduction of 5 mph. G<sub>2</sub> yields a speed reduction of approximately 3 mph. The total of 8 mph is less than the maximum 10 mph speed reduction. Therefore, the critical length of grade is not exceeded.

### **Example 33-2.3**

**Given:** Figure 33-2.C illustrates the vertical alignment on a low-volume, two-lane rural collector highway with no large trucks. It is a Class III Truck Route.

**Problem:** Determine if the critical length of grade is exceeded for G<sub>2</sub> or for the combination upgrade G<sub>3</sub> and G<sub>4</sub>.

**Solution:** Use the following steps:

Step 1. Determine the length of grade using the criteria in Figure 33-2.B. For this example, these are calculated as follows:

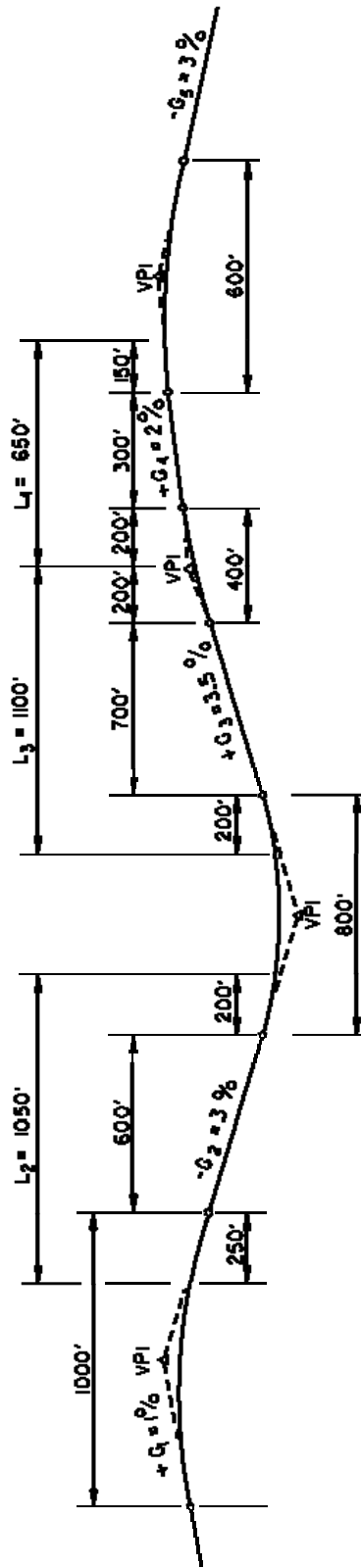

**CRITICAL LENGTH OF GRADE CALCULATIONS**  
(Example 33-2.3)

**Figure 33-2.C**

$$L_2 = \frac{1000}{4} + 600 + \frac{800}{4} = 1050 \text{ ft}$$

$$L_3 = \frac{800}{4} + 700 + \frac{400}{2} = 1100 \text{ ft}$$

$$L_4 = \frac{400}{2} + 300 + \frac{600}{4} = 650 \text{ ft}$$

Step 2. Determine the critical length of grade in both directions. On a Class III Truck Route, use Figure 33-2.A to determine the critical length of grade.

- For trucks traveling left to right, enter into Figure 33-2.A the value for  $G_3$  (3.5%) and  $L_3 = 1100$  ft. The speed reduction is 7.0 mph. For  $G_4$  (2%) and  $L_4 = 650$  ft, the speed reduction is approximately 3.5 mph. The total speed reduction on the combination upgrade  $G_3$  and  $G_4$  is 10.5 mph. This exceeds the maximum 10 mph speed reduction. However, on low-volume roads, one can assume a 5 mph increase in truck speed for the 3% “momentum” grade ( $G_2$ ) which precedes  $G_3$ . Therefore, a speed reduction may be as high as 15 mph before concluding that the combination grade exceeds the critical length of grade. Assuming the benefits of the momentum grade, this leads to the conclusion that the critical length of grade is not exceeded.
- For trucks traveling in the opposite direction, on Figure 33-2.A, enter in the value for  $G_2$  (3%) and determine the critical length of grade for the 10 mph speed reduction (i.e., 1700 ft). Because  $L_2$  is less than 1700 ft (i.e., 825 ft), the critical length of grade for this direction is not exceeded.

\*\*\*\*\*

### 33-3 TRUCK-CLIMBING LANES

#### 33-3.01 Warrants

A truck-climbing lane may be warranted to allow a specific upgrade to operate at an acceptable level of service. The following criteria will apply.

##### 33-3.01(a) Two-Lane Highways

On a two-lane, two-way highway, a truck-climbing lane generally will be warranted if the following conditions are satisfied:

- the critical length of grade is exceeded for the 10 mph (15 km/h) speed reduction curve (see Figure 33-2.A); and
- the heavy-vehicle volume (i.e., trucks, buses, and recreational vehicles) exceeds 20 veh/h during the design hour; and
- one of the following conditions exists:
  - + the level of service (LOS) on the upgrade is E or F, or
  - + there is a reduction of two or more LOS when moving from the approach segment to the upgrade, and the LOS on the upgrade is E or F; and
  - + the construction costs and the construction impacts (e.g., environmental, right-of-way) are considered reasonable.

Also, truck-climbing lanes may be warranted where the above criteria are not met and if there is an adverse crash experience on the upgrade related to slow-moving trucks.

##### 33-3.01(b) Multilane Highways

A truck-climbing lane generally will be warranted on a multilane highway if the following conditions are satisfied:

- the critical length of grade is exceeded for the 10 mph (15 km/h) speed reduction curve (see Figure 33-2.A); and
- the directional service volume exceeds 1000 veh/h; and
- one of the following conditions exists:
  - + the LOS on the upgrade is E or F, or
  - + there is a reduction of one or more LOS when moving from the approach segment to the upgrade; and

- + the construction costs and the construction impacts (e.g., environmental, right-of-way) are considered reasonable.

Also, truck-climbing lanes may be warranted where the above criteria are not met and if there is an adverse crash experience on the upgrade related to slow-moving trucks.

### **33-3.02 Capacity Analysis**

See the *Highway Capacity Manual* for guidance on conducting capacity analyses for climbing lanes on two-lane and multilane highways.

### **33-3.03 Design Guidelines**

Figure 33-3.A summarizes the design criteria for a truck-climbing lane. Also consider the following:

1. Design Speed. For entering speeds equal to or greater than 55 mph (90 km/h), use 55 mph (90 km/h) for the truck design speed. For speeds less than 55 mph (90 km/h), use the roadway design speed or the posted speed limit, whichever is less. Under restricted conditions, the designer may want to consider the effect a momentum grade will have on the entering speed. See Section 33-2.04 for additional information on momentum grades. However, the maximum speed will be 55 mph (90 km/h).
2. Superelevation. For horizontal curves, superelevate the truck-climbing lane at the same rate as the adjacent travel lane. When selecting the superelevation rate, consider the following:
  - a. Snow and Ice Conditions. Where snow and ice conditions are expected, the selected superelevation rate should not exceed 6%.
  - b. New Construction. The maximum superelevation rate should not exceed 6%.
  - c. Reconstruction and 3R Projects. The maximum superelevation rate is 8%. However, where practical, select a horizontal curve radii so that the actual superelevation rate is 6% or less.
  - d. Curves to the Left. Where there is a curve to the left, use as flat of a curve as practical to minimize superelevation and reduce the possibility of vehicles sliding down the cross slope during icy conditions into opposing traffic.
3. Performance Curves. Figure 33-3.B presents the deceleration and acceleration rates for a 200 lb/hp (120 kg/kW) truck.

Design Element	Desirable	Minimum
Lane Width	12 ft (3.6 m)	Freeway/Expressway: 12 ft (3.6 m) Other Facilities: 11 ft (3.3 m)
Shoulder Width	6 ft (1.8 m)	4 ft – 6 ft (1.2 m – 1.8 m)
Cross Slope on Tangent	¼"/ft (2%)	¼"/ft (2%)
Beginning of Full-Width Lane <sup>(1)</sup>	Location where the truck speed has been reduced to 10 mph (15 km/h) below the posted speed limit.	Location where the truck speed has been reduced to 45 mph (70 km/h).
End of Full-Width Lane <sup>(2)</sup>	Location where truck has reached highway posted speed or 55 mph (90 km/h), whichever is less.	Location where truck has reached 10 mph (15 km/h) below highway posted speed limit.
Entering Taper	25:1	300 ft (90 m)
Exiting Taper	600 ft (180 m)	50:1
Minimum Full-Width Length	1000 ft (300 m) or greater	1000 ft (300 m)

*Notes:*

1. Use Figure 33-3.B to determine truck deceleration rates. In determining the applicable truck speed, the designer may consider the effect of momentum grades.
2. Use Figure 33-3.B to determine truck acceleration rates. Also, see Comment 4 in Section 33-3.03.

**DESIGN CRITERIA FOR TRUCK-CLIMBING LANES**

**Figure 33-3.A**

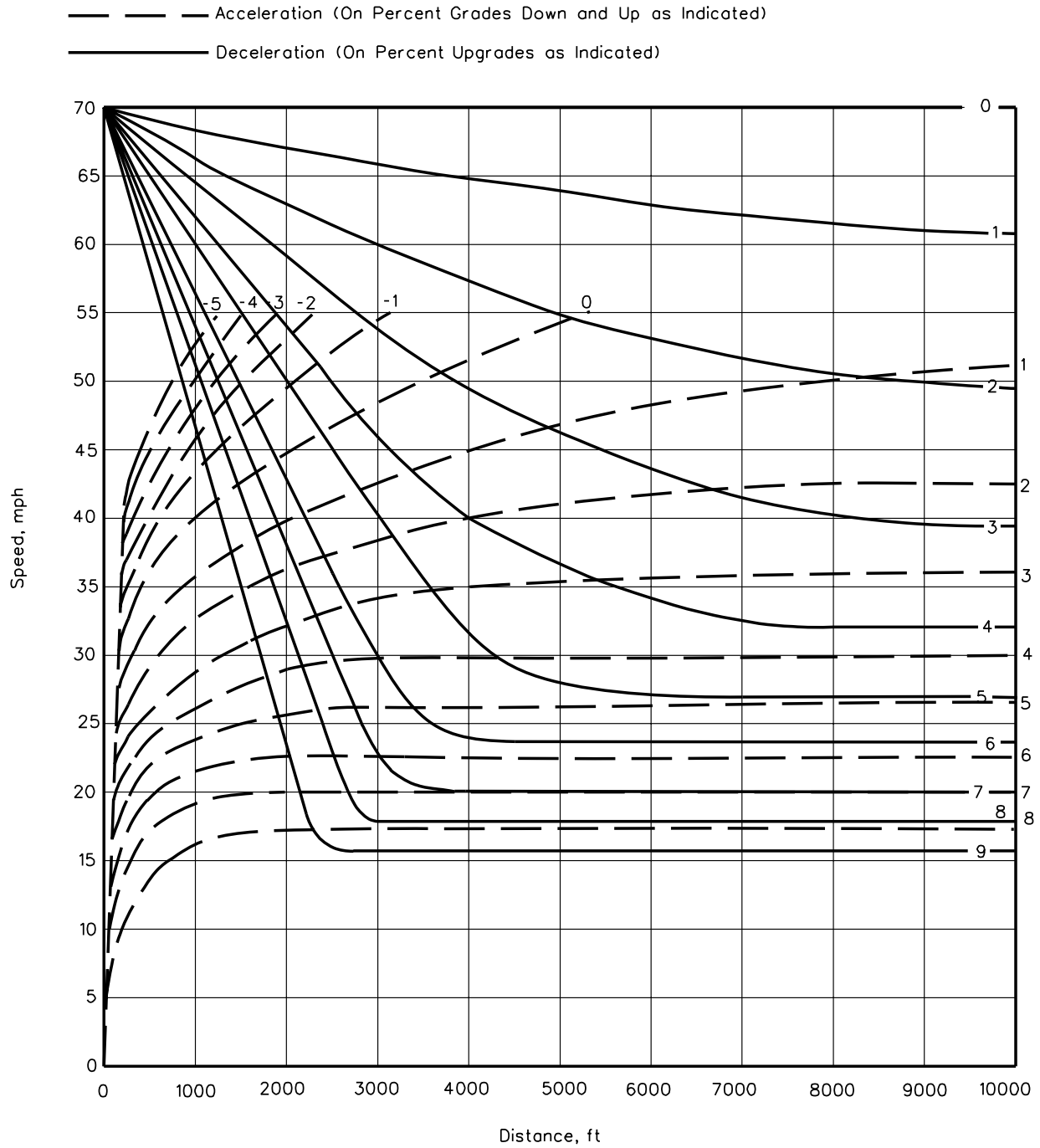

Note: For entering speeds equal to or greater than 70 mph, use an initial speed of 70 mph. For speeds less than 70 mph, use the design speed or posted speed limit as the initial speed.

**PERFORMANCE CURVES FOR TRUCKS  
(200 lb/hp) (US Customary)**

**Figure 33-3.B**

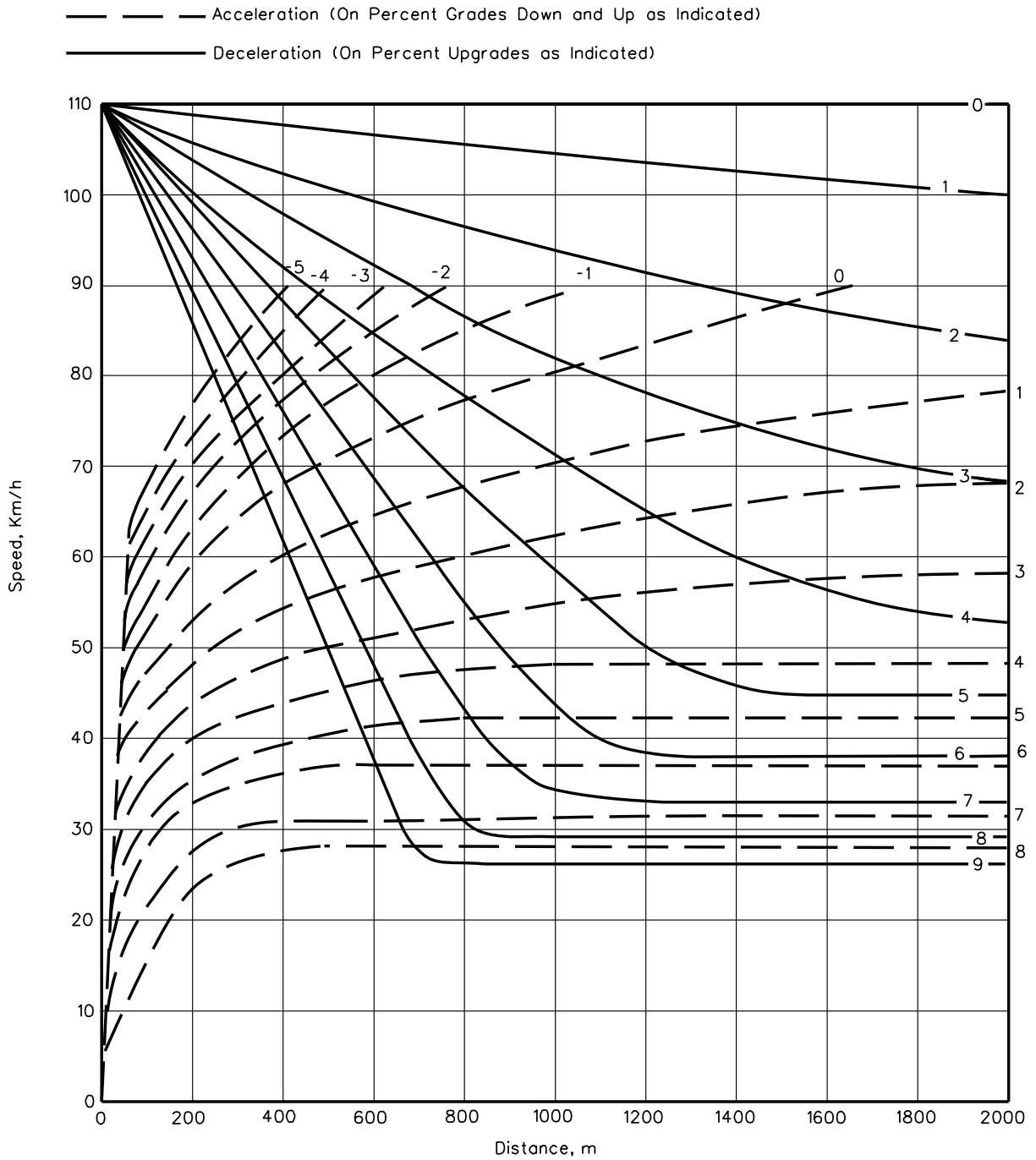

Note: For entering speeds equal to or greater than 110 km/h, use an initial speed of 110 km/h. For speeds less than 110 km/h, use the design speed or posted speed limit as the initial speed.

**PERFORMANCE CURVES FOR TRUCKS  
(120 kg/kW) (Metric)**

**Figure 33-3.B**

4. End of Full-Width Lane. In addition to the criteria in Figure 33-3.A, ensure that there is sufficient sight distance available to the point where the truck, RV, or bus will begin to merge back into the through travel lane. At a minimum, this will be stopping sight distance. Desirably, the driver should have decision sight distance available to the end of the taper. See Section 31-3 for decision sight distance values.

Do not end the full lane width just beyond a crest vertical curve, but instead extend it beyond the crest vertical curve. The full lane width should not end on a horizontal curve.

5. Signing and Pavement Markings. Figure 33-3.C illustrates the Department's practice for signing and marking climbing lanes. Where deemed necessary, contact the district Bureau of Operations for additional information.

### 33-3.04 Downgrades

Truck lanes on downgrades are not typically considered. However, steep downhill grades may also have a detrimental effect on the capacity and safety of facilities with high traffic volumes and numerous heavy trucks. Although specific criteria have not been established for these conditions, trucks descending steep downgrades in low gear may produce nearly as great an effect on operations as an equivalent upgrade. The need for a truck lane for downhill traffic will be considered on a site-by-site basis.

### 33-3.05 Truck Speed Profile

For highways with a single grade, the critical length of grade and deceleration and acceleration rates can be directly determined from Figure 33-3.B. However, most highways have a continuous series of grades. Often, it is necessary to find the impact of a series of significant grades in succession. If several different grades are present, then a speed profile may need to be developed.

The following example illustrates how to construct a truck speed profile and how to use Figure 33-3.B.

\* \* \* \* \*

#### Example 33-3.2

Given: Level Approach  
 $G_1 = +3\%$  for 800 ft (VPI to VPI)  
 $G_2 = +5\%$  for 3200 ft (VPI to VPI)  
 $G_3 = -2\%$  beyond the composite upgrade ( $G_1$  and  $G_2$ )  
 $V = 60$  mph design speed with a 55 mph posted speed limit  
 Rural Principal Arterial (Class I Truck Route)

Problem: Using the criteria in Figure 33-3.A and Figure 33-3.B, construct a truck speed profile and determine the beginning and ending points of the full-width climbing lane.

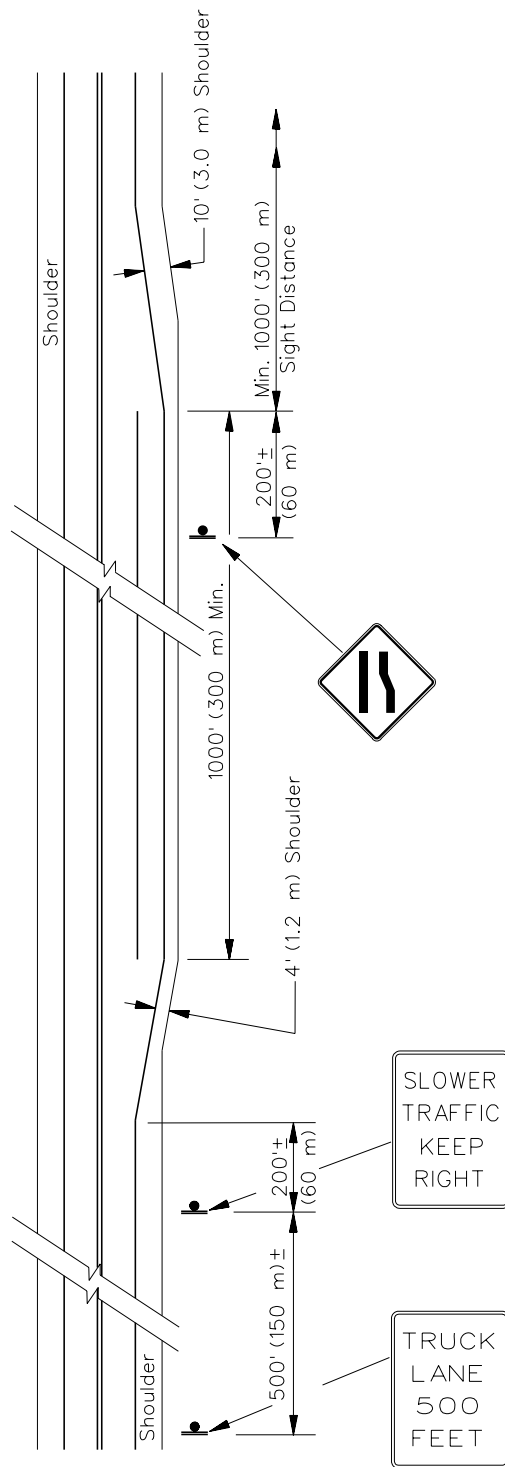

CLIMBING LANE MARKINGS

Figure 33-3.C

**Solution:** Apply the following steps:

**Step 1:** Determine the truck speed on  $G_1$  using Figure 33-3.B and plot the truck speed at 200 ft increments in Figure 33-3.D. Assume an initial truck speed of 55 mph. Move horizontally along the 55 mph line to the 3% deceleration curve. This is approximately 2800 ft along the horizontal axis. This is the starting point for  $G_1$ .

Distance From VPI <sub>1</sub> (ft)	Horizontal Distance on Figure 33-3.B(ft)	Truck Speed (mph)	Comments
0	2800	55	VPI <sub>1</sub>
200	3000	54	
400	3200	53	
600	3400	52	
800	3600	51	VPI <sub>2</sub>

**Step 2:** Determine the truck speed on  $G_2$  using Figure 33-3.B and plot the truck speed at 200 ft increments in Figure 33-3.D. From Step 1, the initial speed on  $G_2$  is the final speed from  $G_1$  (i.e., 51 mph). Move right horizontally along the 51 mph line to the 5% deceleration curve. This is approximately 1900 ft along the horizontal axis. This is the starting point for  $G_2$ .

Figure 33-3.D Distance From VPI <sub>1</sub> (ft)	Horizontal Distance on Figure 33-3.B (ft)	Truck Speed (mph)	Comments
800	1900	51	VPI <sub>2</sub>
1000	2100	49	
1200	2300	47	
1400	2500	45	
1600	2700	43	
1800	2900	41	
2000	3100	39	
2200	3300	37	
2400	3500	35	
2600	3700	33	
2800	3900	32	
3000	4100	31	
3200	4300	30	
3400	4500	29	
3600	4700	29	
3800	4900	28	
4000	5100	28	VPI <sub>3</sub>

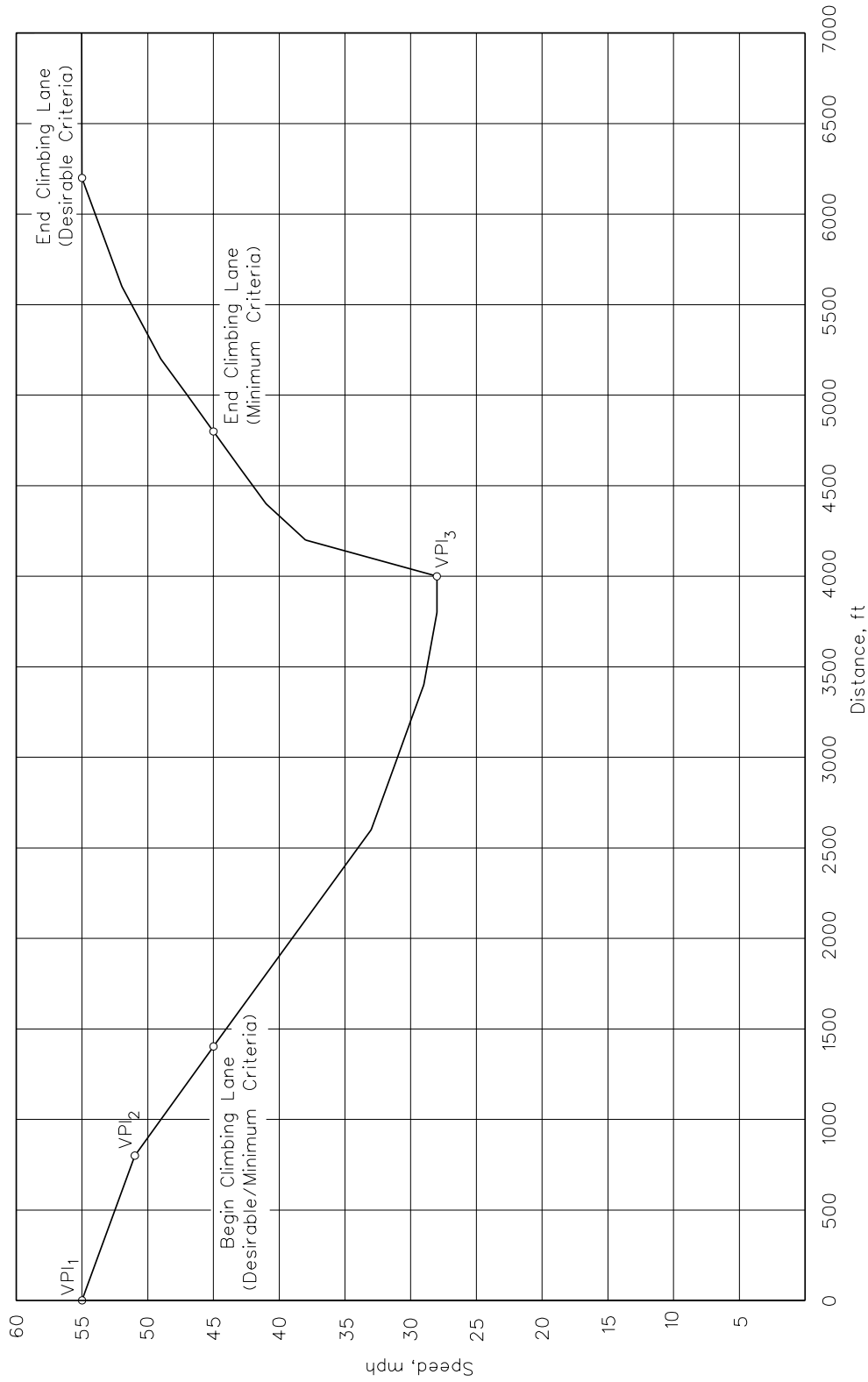

**TRUCK SPEED PROFILE**  
(Example 33-3.2)

Figure 33-3.D

**Step 3:** Determine the truck speed on  $G_3$  using Figure 33-3.B until the truck has fully accelerated to 55 mph and plot the truck speed at 200 ft increments in Figure 33-3.D. The truck will have a speed of 28 mph as it enters the 2% downgrade at  $VPI_3$ . Read into Figure 33-3.B at the 28 mph point on the vertical axis and move over horizontally to the -2% line. This is approximately 150 ft along the horizontal axis. This is the starting point for  $G_3$ .

Figure 33-3.D Distance From $VPI_1$ (ft)	Horizontal Distance on Figure 33-3.B (ft)	Truck Speed (mph)	Comments
4000	150	28	$VPI_3$
4200	350	38	
4400	550	41	
4600	750	43	
4800	950	45	
5000	1150	47	
5200	1350	49	
5400	1550	50	
5600	1750	52	
5800	1950	53	
6000	2150	54	
6200	2350	55	

**Step 4:** Determine the beginning and end of the full-width climbing lane. From Figure 33-3.A, the desirable and minimum beginning of the full-width lane will be where the truck has reached a speed of 45 mph (10 mph below the posted speed). This point occurs 1400 ft beyond  $VPI_1$ .

For ending the full-width climbing lane, the desirable criteria from Figure 33-3.A is where the truck speed has reached the posted speed limit (55 mph) or 6200 ft beyond the  $VPI_1$ . The minimum criteria is where the truck has reached a speed of 45 mph (10 mph below the posted speed). This occurs at 4800 ft beyond  $VPI_1$ .

### 33-4 VERTICAL CURVES

#### 33-4.01 Crest Vertical Curves

Crest vertical curves are in the shape of a parabola. The basic equations for determining the minimum length of a crest vertical curve are:

$$L = \frac{AS^2}{200(\sqrt{h_1} + \sqrt{h_2})^2} \quad \text{Equation 33-4.1}$$

$$K = \frac{S^2}{200(\sqrt{h_1} + \sqrt{h_2})^2} \quad \text{Equation 33-4.2}$$

$$L=KA \quad \text{Equation 33-4.3}$$

where:

- L = length of vertical curve, ft (m)
- A = algebraic difference between the two tangent grades, %
- S = sight distance, ft (m)
- $h_1$  = height of eye above road surface, ft (m)
- $h_2$  = height of object above road surface, ft (m)
- K = horizontal distance needed to produce a 1% change in gradient

The length of a crest vertical curve will depend upon "A" for the specific curve and upon the selected sight distance, height of eye, and height of object. Equation 33-4.1 and the resultant values of K are predicated on the sight distance being less than the length of vertical curve. However, these values can also be used, without significant error, where the sight distance is greater than the length of vertical curve. The following sections discuss the selection of K-values. For design purposes, round the calculated length up to the next highest 50 ft (10 m) increment.

#### 33-4.01(a) **Stopping Sight Distance**

The principal control in the design of crest vertical curves is to ensure that minimum stopping sight distance (SSD) is available throughout the vertical curve. The following discusses the application of K-values for various operational conditions:

1. Passenger Cars (Level Grade). Figure 33-4.A presents K-values for passenger cars on a level grade. Level conditions are assumed where the grade on the far side of the vertical curve is less than 3%. These are calculated by assuming  $h_1 = 3.5$  ft (1.080 m),  $h_2 = 2$  ft (600 mm) and  $S = \text{SSD}$  in the basic equation for crest vertical curves (Equation 33-4.1). The values represent the lowest acceptable sight distance on a facility. Where cost effective, use higher stopping sight distances.

2. Passenger Cars (Grade Adjusted). For a given speed, the safe stopping distance on downgrades is greater than that for a level roadway. Where grades on the far side of a crest vertical curve are  $-3\%$  or greater, design the length of curve using K-values that have been adjusted for the increased braking distances resulting from the downgrade. No adjustment is necessary for grades less than  $3\%$  or for upgrades. Figure 33-4.B presents minimum and desirable K-values adjusted for downgrades for passenger cars. Make every reasonable effort to meet these values where the grade is  $-3\%$  or greater. However, the grade-adjusted K-values do not require a design exception when not met. The level K-values in Figure 33-4.A apply when determining whether or not a design exception for stopping sight distance will be required; see Section 31-8.
3. Minimum Length. For design speeds of 60 mph (100 km/h) or less, the minimum length of a crest vertical curve in feet (meters) should be  $3V$  ( $0.6V$ ), where  $V$  is the design speed in mph (km/h). For design speeds greater than 60 mph (100 km/h), the minimum length of a crest vertical curve in feet (meters) should be  $5V$  ( $1V$ ). These distances apply regardless of the calculated length of vertical curve. For aesthetics, the suggested minimum length of a crest vertical curve on a rural highway is 1000 ft (300 m).

#### **33-4.01(b) Decision Sight Distance**

At some locations, decision sight distance may be warranted in the design of crest vertical curves. Section 31-3.02 discusses candidate sites and provides design values for decision sight distance. In complex environments, decision sight distance provides drivers with additional time to adjust their speed and additional distance to make unexpected maneuvers. Crest vertical curve designed with decision sight distance will be longer than those using stopping sight distance. These “S” values should be used in the basic equation for crest vertical curves (Equation 33-4.1). In addition, the following will apply:

1. Height of Eye ( $h_1$ ). For passenger cars,  $h_1 = 3.5$  ft (1.080 m).
2. Height of Object ( $h_2$ ). Decision sight distance, in many cases, is predicated upon the same principle as stopping sight distance; i.e., the driver needs sufficient distance to see a 2 ft (600 mm) object. Therefore,  $h_2 = 2$  ft (600 mm) at many locations. However, at some elevations, decision sight distance may be determined assuming the pavement surface (e.g., freeway exit gores). At these locations,  $h_2 = 0.0$  ft (0.0 mm).
3. K-Values. Figure 33-4.C presents the K-values for passenger cars using the decision sight distances presented in Section 31-3.02.

#### **33-4.01(c) Passing Sight Distance**

At some locations, it may be desirable to provide passing sight distance in the design of crest vertical curves. Section 47-2.03 discusses the application and design values for passing sight distance on two-lane, two-way highways. These “S” values are used in the basic equation for crest vertical curves (Equation 33-4.1). In addition, the following will apply:

US Customary				Metric			
Design Speed (mph)	Stopping Sight Distance (ft)	Rate of Vertical Curvature, K <sup>(3)</sup>		Design Speed (km/h)	Stopping Sight Distance (m)	Rate of Vertical Curvature, K <sup>(4)</sup> Design	
		Calculated	Design			Calculated	Design
30	200	18.5	19	50	65	6.4	7
35	250	29.0	29	60	85	11.0	11
40	305	43.1	44	70	105	16.8	17
45	360	60.1	61	80	130	25.7	26
50	425	83.7	84	90	160	38.9	39
55	495	113.5	114	100	185	52.0	52
60	570	150.6	151	110	216	70.9	71
65	645	192.8	193				
70	730	246.9	247				

## Notes:

1. Stopping sight distances (SSD) are from Figure 31-3.A.
2. Maximum K-value for drainage on curbed roadways is 167 (51). Where a crest vertical curve falls on a bridge and the design speed is greater than 60 mph (90 km/h), the design speed consideration will override the drainage maximum. However, to adequately handle shoulder drainage on the bridge, it may be necessary to provide drainage scuppers on the bridges; see the IDOT Drainage Manual.
3. 
$$K = \frac{SSD^2}{2158}, \text{ where: } h_1 = 3.5 \text{ ft, } h_2 = 2 \text{ ft} \quad (\text{US Customary})$$
4. 
$$K = \frac{SSD^2}{658}, \text{ where: } h_1 = 1.080 \text{ m, } h_2 = 600 \text{ mm} \quad (\text{Metric})$$

**K-VALUES FOR CREST VERTICAL CURVES — STOPPING SIGHT DISTANCES  
(Passenger Cars — Level Grades)**

**Figure 33-4.A**

K-VALUES ROUNDED FOR DESIGN								
US Customary								
Design Speed (mph)	(3%)	(4%)	(5%)	(6%)	(7%)	(8%)	(9%)	(10%)
30	20	21	22	22	23	24	25	26
35	32	33	34	35	37	38	39	41
40	46	49	51	52	54	57	59	62
45	67	69	73	75	78	82	86	90
50	94	96	101	105	109	114	121	128
55	126	131	138	143	151	156	164	173
60	167	176	181	190	199	208	221	231
65	218	227	237	247	261	272	290	304
70	279	290	304	316	335	351	372	393
Metric								
Design Speed (km/h)	(3%)	(4%)	(5%)	(6%)	(7%)	(8%)	(9%)	(10%)
50	7	7	7	8	8	8	9	9
60	12	12	13	13	14	14	15	16
70	19	20	20	21	22	23	24	25
80	29	29	31	32	33	35	36	38
90	41	43	45	46	49	51	54	56
100	58	60	63	66	69	73	76	81
110	79	82	87	90	95	100	106	111

## Notes:

1. *K-values in table have been determined by using the SSD rounded for design from Figure 31-3.B.*
2. *For grades less than 3%, no adjustment is necessary; i.e., use the level K-values in Figure 33-4.A.*
3. *For grades intermediate between table values, use a straight-line interpolation in Figure 31-3.B or use Equation 31-3.2 and roundup to the next highest 5 ft (1 m) increment to determine the SSD and then calculate the appropriate K-value.*

$$4. \quad K = \frac{SSD^2}{2158}, \text{ where: } h_1 = 3.5 \text{ ft, } h_2 = 2 \text{ ft} \quad (\text{US Customary})$$

$$5. \quad K = \frac{SSD^2}{658}, \text{ where: } h_1 = 1.080 \text{ m, } h_2 = 600 \text{ mm} \quad (\text{Metric})$$

**K-VALUES FOR CREST VERTICAL CURVES — STOPPING SIGHT DISTANCES  
(Passenger Cars — Adjusted For Downgrades)**

Figure 33-4.B

US Customary											
Design Speed (mph)	Avoidance Maneuver A (Stop on Rural Road)		Avoidance Maneuver B (Stop on Urban Road)		Avoidance Maneuver C (Speed/Path/Direction Change on Rural Road)		Avoidance Maneuver D (Speed/Path/Direction Change on Suburban Road)		Avoidance Maneuver E (Speed/Path/Direction Change of Urban Road)		
	DSD (ft)	K-Value	DSD (ft)	K-Value	DSD (ft)	K-Value	DSD (ft)	K-Value	DSD (ft)	K-Value	
30	220	23	490	112	450	94	535	133	620	179	
35	275	35	590	162	525	128	625	181	720	241	
40	330	51	690	221	600	167	715	237	825	316	
45	395	73	800	297	675	211	800	297	930	401	
50	465	101	910	384	750	261	890	367	1030	492	
55	535	133	1030	492	865	347	980	445	1135	597	
60	610	173	1150	613	990	455	1125	587	1280	760	
65	695	224	1275	754	1050	511	1220	690	1365	864	
70	780	282	1410	922	1105	566	1275	754	1445	968	
Metric											
(km/h)	DSD (m)	K-Value	DSD (m)	K-Value	DSD (m)	K-Value	DSD (m)	K-Value	DSD (m)	K-Value	
50	70	8	155	37	145	32	170	44	195	58	
60	95	14	195	58	170	44	205	64	235	84	
70	115	21	235	84	200	61	235	84	275	115	
80	140	30	280	120	230	81	270	111	315	151	
90	170	44	325	161	270	111	315	151	360	197	
100	200	61	370	209	315	151	355	192	400	244	
110	235	84	420	269	330	166	380	220	430	281	

Notes:

1. See Section 31-3.02 for decision sight distances (DSD).

2.  $K = \frac{DSD^2}{2158}$ , where:  $h_1 = 3.5 \text{ ft}$ ,  $h_2 = 2 \text{ ft}$  (US Customary)

3.  $K = \frac{DSD^2}{658}$ , where:  $h_1 = 1.080 \text{ m}$ ,  $h_2 = 600 \text{ mm}$  (Metric)

4. Where it is desirable to see the road surface, the object height,  $h_2$ , may be set at zero and the K-values recalculated.

**K-VALUES FOR CREST VERTICAL CURVES — DECISION SIGHT DISTANCE (Passenger Cars)**

Figure 33-4.C

1. Height of Eye ( $h_1$ ). For passenger cars,  $h_1 = 3.5$  ft (1.080 m).
2. Height of Object ( $h_2$ ). Passing sight distance is predicated upon the passing driver being able to see a sufficient portion of the top of the oncoming car. Therefore,  $h_2 = 3.5$  ft (1.080 m).
3. K-Values. Figure 33-4.D presents the K-values for passenger cars using the passing sight distances presented in Section 47-2.03.

### 33-4.01(d) Drainage

Proper drainage must be considered in the design of crest vertical curves on curbed sections, bridges, and medians with concrete barriers. Typically, drainage problems will not be experienced if the vertical curvature is sharp enough so that a minimum longitudinal gradient of at least 0.3% is reached at a point about 50 ft (15 m) from either side of the apex. To ensure that this objective is achieved, determine the length of the crest vertical curve assuming a K-value of 167 (51) or less. Where a crest vertical curve lies within a curbed section or bridge and where the maximum drainage K-value is exceeded, carefully evaluate the drainage design near the apex. If a bridge is within a crest vertical curve and the design speed is greater than 60 mph (90 km/h), the design speed consideration will override the drainage maximum. However, to adequately handle the shoulder drainage, it may be necessary to provide drainage scuppers on the bridge. See the *IDOT Drainage Manual* for more information.

For uncurbed sections of highway, drainage should not be a problem at crest vertical curves. However, it still may be desirable to provide a longitudinal gradient of at least 0.15% at points about 50 ft (15 m) on either side of the high point. To achieve this, K must equal 334 (100) or less.

### 33-4.02 Sag Vertical Curves

Sag vertical curves are in the shape of a parabola. Typically, they are designed to allow the vehicular headlights to illuminate the roadway surface (i.e., the height of object = 0.0 ft (0.0 mm)) for a given distance "S." The light beam from the headlights is assumed to have a  $1^\circ$  upward divergence from the longitudinal axis of the vehicle. These assumptions yield the following basic equations for determining the minimum length of sag vertical curves:

$$L = \frac{AS^2}{200[h_3 + S(\tan 1^\circ)]} = \frac{AS^2}{200h_3 + 3.5S} \quad \text{Equation 33-4.4}$$

$$K = \frac{S^2}{200h_3 + 3.5S} \quad \text{Equation 33-4.5}$$

$$L = KA \quad \text{Equation 33-4.6}$$

US Customary			Metric		
Design Speed (mph)	Passing <sup>(1)</sup> Sight Distance (ft)	Rate of Vertical Curvature, K <sup>(2)</sup> Design	Design Speed (km/h)	Passing <sup>(1)</sup> Sight Distance (m)	Rate of Vertical Curvature, K <sup>(3)</sup> Design
30	1090	424	50	345	138
35	1280	585	60	410	195
40	1470	772	70	485	272
45	1625	943	80	540	338
50	1835	1203	90	615	438
55	1985	1407	100	670	520
60	2135	1628	110	730	617
65	2285	1865			
70	2480	2197			

Notes:

1. Design passing sight distances (PSD) are from Section 47-2.03.

2.  $K = \frac{PSD^2}{2800}$ , where:  $h_1 = 3.5$  ft,  $h_2 = 3.5$  ft (US Customary)

3.  $K = \frac{PSD^2}{864}$ , where:  $h_1 = 1.080$  m,  $h_2 = 1.080$  m (Metric)

**K-VALUES FOR CREST VERTICAL CURVES — PASSING SIGHT DISTANCES  
(Passenger Cars)**

**Figure 33-4.D**

where: L = length of vertical curve, ft (m)  
A = algebraic difference between the two tangent grades, %  
S = sight distance, ft (m)  
 $h_3$  = height of headlights above pavement surface, ft (m)  
K = horizontal distance needed to produce a 1% change in gradient

The length of a sag vertical curve will depend upon “A” for the specific curve and upon the selected sight distance and headlight height. Equation 33-4.4 and the resultant values of K are predicated on the sight distance being less than the length of vertical curve. However, these values can also be used, without significant error, where the sight distance is greater than the length of vertical curve. The following sections discuss the selection of K-values.

### 33-4.02(a) Stopping Sight Distance

The principal control in the design of sag vertical curves is to ensure a minimum stopping sight distance (SSD) is available for headlight illumination throughout the sag vertical curve. The following discusses the application of K-values for various operational conditions:

1. Passenger Cars (Level Grade). Figure 33-4.E presents K-values for passenger cars. These are calculated by assuming  $h_3 = 2$  ft (600 mm) and  $S = SSD$  in the basic equation for sag vertical curves (Equation 33-4.4). The minimum values represent the lowest acceptable sight distance on a facility. However, because sag vertical curves greatly affect the aesthetics of a highway alignment, use longer than the minimum lengths of curves to provide a more aesthetically pleasing design.
2. Passenger Cars (Grade Adjusted). For a given speed, the safe stopping sight distance on downgrades is greater than that for a level surface. For sag vertical curves, only consider grade adjustments when the sag curve is between two downgrades and where the downgrades are -3% or greater. Figure 33-4.F presents K-values adjusted for grades for passenger cars. However, grade-adjusted K-values do not require a design exception when not met. The level K-values in Figure 33-4.E apply when determining whether or not a design exception for stopping sight distance will be required; see Section 31-8.
3. Minimum Length. For design speeds of 60 mph (100 km/h) or less, the minimum length of a sag vertical curve in feet (meters) should be  $3V$  ( $0.6V$ ), where  $V$  is the design speed in mph (km/h). For design speeds greater than 60 mph (100 km/h), the minimum length of a sag vertical curve in feet (meters) should be  $5V$  ( $1V$ ). For aesthetics on rural highways, the minimum length of a sag vertical curve is dependent upon the driver's view of the highway. The greater the distance a highway can be seen ahead, the longer the sag vertical curve should be.

One exception to the minimum length on sag vertical curves applies in curbed sections and on bridges. If the sag is in a low point, the use of the minimum length criteria may produce longitudinal slopes too flat to drain stormwater without ponding. For additional guidance, see Chapter 40 of the *BDE Manual* and the *IDOT Drainage Manual*.

US Customary				Metric			
Design Speed (mph)	Stopping Sight Distance (ft)	Rate of Vertical Curvature, K <sup>(3)</sup>		Design Speed (km/h)	Stopping Sight Distance (m)	Rate of Vertical Curvature, K <sup>(4)</sup>	
		Calculated (ft)	Design (ft)			Calculated (m)	Design (m)
30	200	36.4	37	50	64	11.9	12
35	250	49.0	49	60	83	16.8	17
40	305	63.4	64	70	105	22.6	23
45	360	78.1	79	80	129	29.1	30
50	425	95.7	96	90	156	36.5	37
55	495	114.9	115	100	185	44.6	45
60	570	135.7	136	110	216	53.3	54
65	645	156.5	157				
70	730	180.3	181				

## Notes:

1. Stopping sight distances (SSD) are from Figure 31-3.A.
2. Maximum K-value for drainage on curbed roadways and bridges is 167 (51).
3. 
$$K = \frac{SSD^2}{400 + 3.5SSD}, \text{ where: } h_3 = 2 \text{ ft} \quad (\text{US Customary})$$
4. 
$$K = \frac{SSD^2}{120 + 3.5SSD}, \text{ where: } h_3 = 600 \text{ mm} \quad (\text{Metric})$$

**K-VALUES FOR SAG VERTICAL CURVES — STOPPING SIGHT DISTANCES  
(Passenger Cars — Level Grades)**

**Figure 33-4.E**

<b>K VALUES ROUNDED FOR DESIGN</b>								
<b>US Customary</b>								
Design Speed (mph)	(3%)	(4%)	(5%)	(6%)	(7%)	(8%)	(9%)	(10%)
30	38	39	41	41	42	43	44	46
35	52	53	55	56	57	59	60	61
40	67	69	71	72	73	76	77	80
45	84	85	88	89	92	95	98	100
50	103	104	107	110	113	115	120	124
55	122	125	129	132	136	139	143	147
60	144	149	151	156	160	164	170	174
65	168	172	177	181	186	191	198	203
70	193	198	203	208	215	220	227	234
<b>Metric</b>								
Design Speed (km/h)	(3%)	(4%)	(5%)	(6%)	(7%)	(8%)	(9%)	(10%)
50	13	13	13	14	14	14	15	15
60	18	19	19	20	20	20	21	22
70	24	25	26	26	27	28	28	29
80	32	32	33	34	35	36	36	38
90	39	40	41	42	43	45	46	47
100	48	49	50	51	53	54	56	58
110	57	58	60	61	63	65	67	69

**Notes:**

1. *K-values in table have been determined by using the SSD rounded for design from Figure 31-3.B.*
2. *For grades less than 3%, no adjustment is necessary; i.e., use the level K-values in Figure 33-4.E.*
3. *For grades intermediate between table values, use a straight-line interpolation in Figure 31-3.B to determine the SSD and then calculate the appropriate K-value.*

$$4. \quad K = \frac{SSD^2}{400 + 3.5 SSD}, \text{ where: } h_3 = 2 \text{ ft} \quad (\text{US Customary})$$

$$5. \quad K = \frac{SSD^2}{120 + 3.5 SSD}, \text{ where: } h_3 = 600 \text{ mm} \quad (\text{Metric})$$

**K-VALUES FOR SAG VERTICAL CURVES — STOPPING SIGHT DISTANCES  
(Passenger Cars — Adjusted For Downgrades)**

**Figure 33-4.F**

**33-4.02(b) Decision Sight Distance**

At some locations, decision sight distance may be warranted in the design of sag vertical curves. Section 31-3.02 discusses candidate sites and provides design values for decision sight distance. In complex environments, decision sight distance provides drivers with additional time to adjust their speed or additional distance to make unexpected maneuvers. Sag vertical curves designed with decision sight distance will be longer than those using stopping sight distance. These “S” values should be used in the basic equation for sag vertical curves (Equation 33-4.4). The height of headlights  $h_3 = 2$  ft (600 mm). Figure 33-4.G provides K-values for sag vertical curves using decision sight distance.

**33-4.02(c) Comfort Criteria**

On fully lighted, continuous sections of highway and where it is impractical to provide stopping sight distance, a sag vertical curve may be designed to meet the comfort criteria. These criteria are based on the effect of change in the vertical direction of a sag vertical curve due to the combined gravitational and centrifugal forces. The general consensus is that riding is comfortable on sag vertical curves when the centripetal acceleration does not exceed  $1 \text{ ft/s}^2$  ( $0.3 \text{ m/s}^2$ ). The length-of-curve equation for the comfort criteria is:

$$L = \frac{AV^2}{46.5} \quad \text{(US Customary) Equation 33-4.7}$$

$$L = \frac{AV^2}{395} \quad \text{(Metric) Equation 33-4.7}$$

where: L = length of vertical curve, ft (m)  
 A = algebraic difference between the two tangent grades, %  
 V = design speed, mph (km/h)

**33-4.02(d) Underpasses**

Check sag vertical curves through underpasses to ensure that the underpass structure does not obstruct the driver’s visibility. Use the following equation to check sag vertical curves through underpasses:

$$L = \frac{AS^2}{800(C - 4.25)} \quad \text{(US Customary) Equation 33-4.8}$$

$$L = \frac{AS^2}{800(C - 1.3)} \quad \text{(Metric) Equation 33-4.8}$$

where: L = length of vertical curve, ft (m)  
 A = algebraic difference between the two tangent grades, %  
 S = sight distance, ft (m)  
 C = vertical clearance of underpass, ft (m)

US Customary											
Design Speed (mph)	Avoidance Maneuver A (Stop on Rural Road)		Avoidance Maneuver B (Stop on Urban Road)		Avoidance Maneuver C (Speed/Path/Direction Change on Rural Road)		Avoidance Maneuver D (Speed/Path/Direction Change on Suburban Road)		Avoidance Maneuver E (Speed/Path/Direction Change of Urban Road)		
	DSD (ft)	K-Value	DSD (ft)	K-Value	DSD (ft)	K-Value	DSD (ft)	K-Value	DSD (ft)	K-Value	
30	220	42	490	114	450	103	535	126	620	150	
35	275	56	590	142	525	124	625	151	720	178	
40	330	70	690	170	600	144	715	177	825	208	
45	395	88	800	200	675	165	800	200	930	237	
50	465	107	910	231	750	186	890	226	1030	265	
55	535	126	1030	265	865	219	980	251	1135	295	
60	610	147	1150	299	990	254	1125	292	1280	336	
65	695	171	1275	335	1050	271	1220	319	1365	360	
70	780	195	1410	373	1105	287	1275	335	1445	383	

Metric												
(km/h)	DSD (m)		DSD (m)		DSD (m)		DSD (m)		DSD (m)		DSD (m)	
	DSD (m)	K-Value	DSD (m)	K-Value	DSD (m)	K-Value	DSD (m)	K-Value	DSD (m)	K-Value	DSD (m)	K-Value
50	70	14	155	38	145	34	170	41	195	48		
60	95	20	195	51	170	41	205	51	235	59		
70	115	26	235	63	200	49	235	59	275	70		
80	140	33	280	77	230	58	270	69	315	82		
90	170	41	325	94	270	69	315	82	360	94		
100	200	49	370	110	315	82	355	93	400	106		
110	235	59	420	121	330	86	380	100	430	114		

Notes:

1. See Section 31-3.02 for decision sight distances (DSD).

2.  $K = \frac{DSD^2}{400 + 3.5 DSD}$ , where:  $h_3 = 2 \text{ ft}$  (US Customary)

3.  $K = \frac{DSD^2}{120 + 3.5 DSD}$ , where:  $h_3 = 600 \text{ mm}$  (Metric)

**K-VALUES FOR SAG VERTICAL CURVES — DECISION SIGHT DISTANCES (Passenger Cars)**

Figure 33-4.G

Compare the L calculated from Equation 33-4.8 for underpasses with the L calculated based on headlight illumination (Equation 33-4.4). The larger of the two lengths will govern.

### 33-4.02(e) Drainage

Proper drainage must be considered in the design of sag vertical curves on curbed sections, bridges, and medians with concrete barriers. Drainage problems are minimized if the sag vertical curve is sharp enough so that both of the following criteria are met:

- a minimum longitudinal gradient of at least 0.3% is reached at a point about 50 ft (15 m) from either side of the low point, and
- there is at least a 4 in (100 mm) elevation differential between the low point in the sag and the two points 50 ft (15 m) to either side of the low point.

To ensure that the first objective is achieved, base the length of the vertical curve upon a K-value of 167 (51) or less. For most design speeds, the K-values are less than 167 (51); see Figure 33-4.E. However, for higher design speeds and/or where longer sag vertical curves are required in curbed sections or on bridges, it may be necessary to install flanking inlets on either side of the low point.

For uncurbed sections of highway, drainage should not be a problem at sag vertical curves.

### 33-4.03 Vertical Curve Computations

The following will apply to the mathematical design of vertical curves:

1. Definitions. Figure 33-4.H presents the common terms and definitions used in vertical curve computations.
2. Measurements. All measurements for vertical curves are made on the horizontal or vertical plane, not along the profile gradeline. With the simple parabolic curve, the vertical offsets from the tangent vary as the square of the horizontal distance from the VPC or VPT. Elevations along the curve are calculated as proportions of the vertical offset at the point of vertical intersection (VPI). The necessary equations for computing a symmetrical vertical curve are shown in Figure 33-4.I. Figure 33-4.J provides an example of how to use these formulas.
3. Unsymmetrical Vertical Curve. Occasionally, it is necessary to use an unsymmetrical vertical curve to obtain clearance on a structure or to meet other existing field conditions. This curve is similar to the parabolic vertical curve, except the curve does not vary symmetrically about the VPI. Note that, with the unsymmetrical vertical curve, the curve is treated as two separate parabolas. The necessary equations for computing an unsymmetrical vertical curve are shown in Figure 33-4.K.

Element	Abbreviation	Definition
Vertical Point of Curvature	VPC	The point at which a tangent grade ends and the vertical curve begins.
Vertical Point of Tangency	VPT	The point at which the vertical curve ends and the tangent grade begins.
Vertical Point of Intersection	VPI	The point where the extension of two tangent grades intersect.
Grade	$G_1, G_2$	The rate of slope between two adjacent VPI's expressed as a percent. The numerical value for percent of grade is the vertical rise or fall in feet (meters) for each 100 ft (100 m) of horizontal distance. Upgrades in the direction of stationing are identified as plus (+). Downgrades are identified as minus (-).
External Distance	E	The vertical distance (offset) between the VPI and the roadway surface along the vertical curve.
Algebraic Difference in Grade	A	The value of A is determined by the deflection in percent between two tangent grades ( $G_2 - G_1$ ).
Length of Vertical Curve	L	The horizontal distance in feet (meters) from the VPC to the VPT.
Tangent Elevation	Tan. Elev.	The elevation on the tangent line between the VPC and VPI and the VPI and VPT.
Elevation on Vertical Curve	Curve Elev.	The elevation of the vertical curve at any given point along the curve.
Horizontal Distance	x	Horizontal distance measured from the VPC or VPT to any point on the vertical curve, in feet (meters).
Tangent Offset	y	Vertical distance from the tangent line to any point on the vertical curve, in feet (meters).
Low/High Point	$x_T$	The station at the high point for crest curves or the low point for sag curves. At this point, the slope of the tangent to the curve is equal to 0%.
Symmetrical Curve	—	The VPI is located at the mid-point between VPC and VPT stationing
Unsymmetrical Curve	—	The VPI is not located at the mid-point between VPC and VPT stationing.

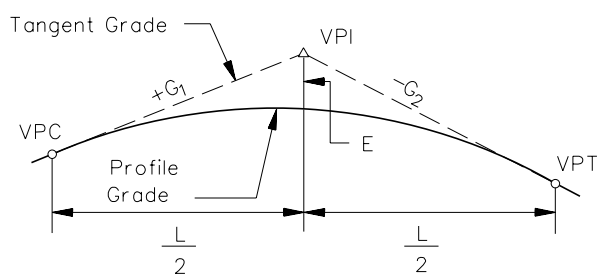

CREST VERTICAL CURVE

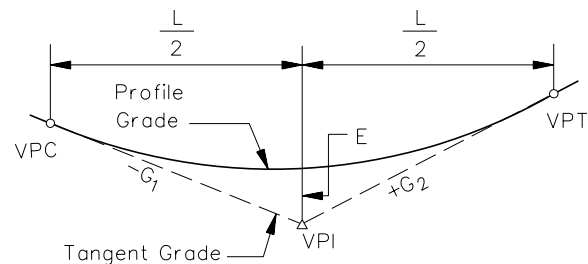

SAG VERTICAL CURVE

**VERTICAL CURVE DEFINITIONS**

**Figure 33-4.H**

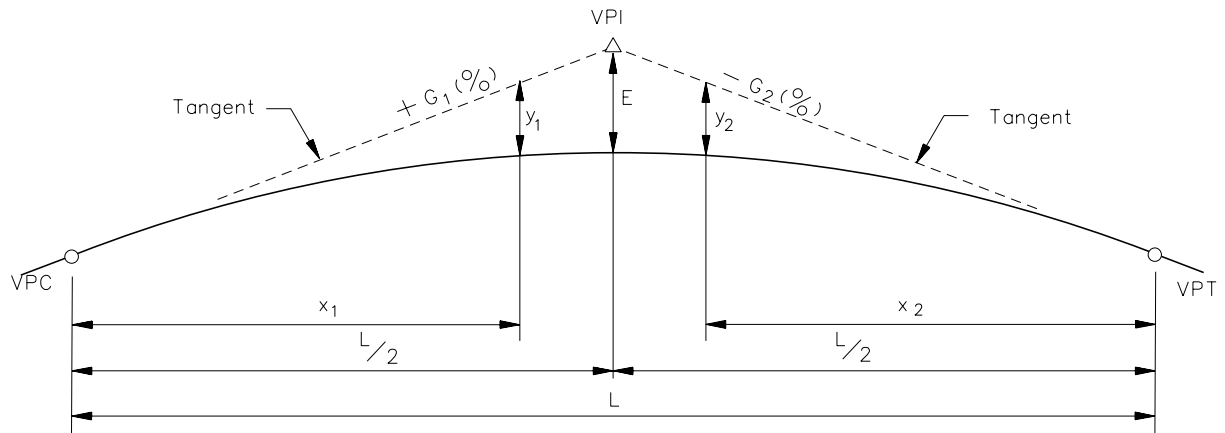

- $E$  = External distance @VPI, ft (m)  
 $y$  = Any tangent offset, ft (m)  
 $L$  = Horizontal length of vertical curve, ft (m)  
 $x$  = Horizontal distance from VPC or VPT to any ordinate "y", ft (m)  
 $G_1$  &  $G_2$  = Rates of grade, expressed algebraically, %

NOTE: ALL EXPRESSIONS TO BE CALCULATED ALGEBRAICALLY  
 (Use algebraic signs of grades; grades in percent.)

1. Elevations of VPC and VPI:

$$\text{VPC ELEV.} = \text{VPI ELEV.} - \left( \frac{G_1}{100} \times \frac{L}{2} \right) \quad \text{Equation 33-4.9}$$

$$\text{VPT ELEV.} = \text{VPI} + \left( \frac{G_2}{100} \times \frac{L}{2} \right) \quad \text{Equation 33-4.10}$$

2. For the elevation of any point "x" on a vertical curve:

$$\text{CURVE ELEV.} = \text{TAN ELEV.} \pm y \quad \text{Equation 33-4.11}$$

Where:

Left of VPI ( $x_1$  measured from VPC):

$$(a) \quad \text{TAN ELEV.} = \text{VPC ELEV.} + \left( \frac{G_1}{100} \right) x_1 \quad \text{Equation 33-4.12}$$

$$(b) \quad y_1 = x_1^2 \frac{(G_2 - G_1)}{200 L} \quad \text{Equation 33-4.13}$$

**SYMMETRICAL VERTICAL CURVE EQUATIONS**

Figure 33-4.1

Right of VPI ( $x_2$  measured from VPT):

$$(a) \quad \text{TAN ELEV.} = \text{VPT ELEV.} - \left( \frac{G_2}{100} \right) x_2 \quad \text{Equation 33-4.14}$$

$$(b) \quad y_2 = x_2^2 \frac{(G_2 - G_1)}{200 L} \quad \text{Equation 33-4.15}$$

At the VPI:

$$y = E \text{ and } x = L / 2$$

$$(a) \quad \text{TAN ELEV.} = \text{VPC ELEV.} + \frac{G_1 L}{200}$$

or  $\text{TAN ELEV.} = \text{VPT ELEV.} - \frac{G_2 L}{200}$  Equation 33-4.16

$$(b) \quad E = \frac{L(G_2 - G_1)}{800} \quad \text{Equation 33-4.17}$$

3. Calculating high or low point in the vertical curve:

(a) To determine distance " $x_T$ " from VPC:

$$x_T = \frac{L G_1}{G_2 - G_1} \quad \text{Equation 33-4.18}$$

(b) To determine high or low point stationing:

$$\text{VPC Sta.} + x_T \quad \text{Equation 33-4.19}$$

(c) To determine high or low point elevation on a vertical curve:

$$\text{ELEV.}_{\text{HIGH OR LOW POINT}} = \text{VPC ELEV.} - \frac{L G_1^2}{(G_2 - G_1) 200} \quad \text{Equation 33-4.20}$$

### SYMMETRICAL VERTICAL CURVE EQUATIONS

**Figure 33-4.1**  
(Continued)

**Example 33-4.1**

Given:  $G_1 = -1.75\%$   
 $G_2 = +2.25\%$   
 Elev. of VPI = 591.00 ft  
 Station of VPI = 10 + 85.00  
 $L = 1200$  ft  
 Symmetrical Vertical Curve  
 Rural Area

Problem: Compute the vertical curve elevations for each 100 ft station. Compute the low point elevation and stationing.

Solution:

1. Draw a diagram of the vertical curve and determine the stationing at the beginning (VPC) and the end (VPT) of the curve.

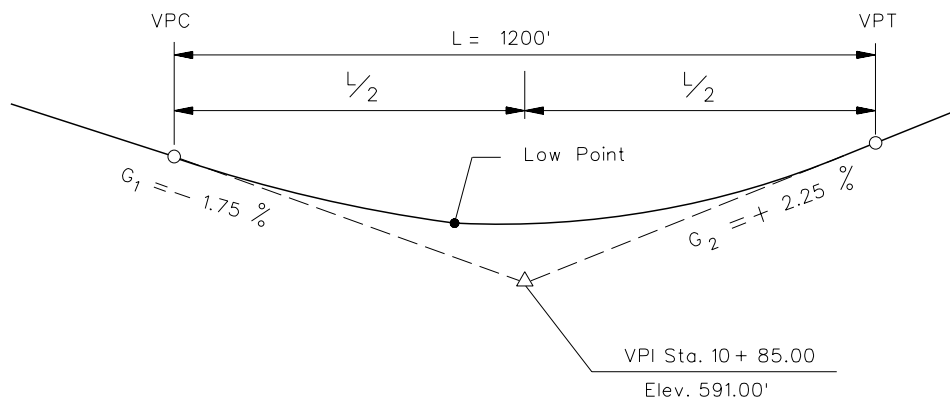

$$\begin{aligned} \text{VPC Station} &= \text{VPI Sta} - \frac{1}{2}L = (10 + 85) - 600 = 4 + 85.00 \\ \text{VPT Station} &= \text{VPI Sta} + \frac{1}{2}L = (10 + 85) + 600 = 16 + 85.00 \end{aligned}$$

2. Elevations of VPC and VPI:

$$\text{VPC ELEV.} = 591.00 - \left( \frac{-1.75}{100} \times \frac{1200}{2} \right) = 601.50 \text{ ft} \quad \text{Equation 33-4.9}$$

$$\text{VPT ELEV.} = 591.00 + \left( \frac{2.25}{100} \times \frac{1200}{2} \right) = 604.50 \text{ ft} \quad \text{Equation 33-4.10}$$

3. Set up a table to show the vertical curve elevations at the 100 ft stations, substituting the values into Equations 33-4.12 through 33-4.15. Calculate the elevation to the nearest 0.01 ft.

**SYMMETRICAL VERTICAL CURVE COMPUTATIONS  
 (Example 33.4-1)**

Figure 33-4.J

**Example 33-4.1**

Solution: (Continued)

Station	Control Point	Tangent Elevation (ft)	x	x <sup>2</sup>	y= x <sup>2</sup> /60,000	Grade Elevation (ft)
4+85	VPC	601.50	0	0	0.00	601.50
5+85		599.75	100	10000	0.17	599.92
6+85		598.00	200	40000	0.67	598.67
7+85		596.25	300	90000	1.50	597.75
8+85		594.50	400	160000	2.67	597.17
9+85		592.75	500	250000	4.17	596.92
10+85	VPI	591.00	600	360000	6.00	597.00
11+85		593.25	500	250000	4.17	597.42
12+85		595.50	400	160000	2.67	598.17
13+85		597.75	300	90000	1.50	599.25
14+85		600.00	200	40000	0.67	600.67
15+85		602.25	100	10000	0.17	602.42
16+85	VPT	604.50	0	0	0.00	604.50

4. Calculate the low point using Equations 33-4.18, 33-4.19, and 33-4.20:

$$x_T = \frac{1200 (-1.75)}{-1.75 - 2.25} = \frac{-2100}{-4.00} = 5 + 25 \text{ ft from VPC}$$

therefore, the Station at the low point is:

$$VPC_{STA} + x_T = (4 + 85) + (5 + 25) = 10 + 10.00$$

elevation at the low point on curve is:

$$\text{Elev. Of low point} = 601.50 - \frac{1200 (-1.75)^2}{(2.25 - (-1.75)) 200} = 601.50 - 4.59 = 596.91 \text{ ft}$$

**VERTICAL CURVE COMPUTATIONS**  
(Example 33-4.1)

**Figure 33-4.J**  
(Continued)

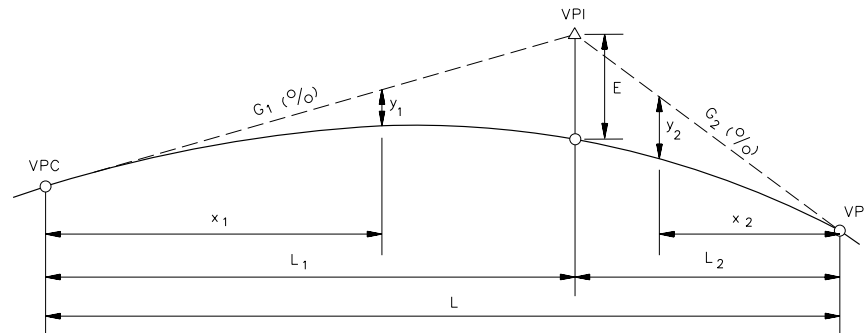

- $E$  = Offset from the VPI to the curve (external distance), ft (m)  
 $y$  = Any tangent offset, ft (m)  
 $L$  = Horizontal length of vertical curve, ft (m)  
 $L_1$  = Horizontal distance from VPC to VPI, ft (m)  
 $L_2$  = Horizontal distance from VPT to VPI, ft (m)  
 $x$  = Horizontal distance from VPC or VPT to any ordinate “ $y$ ”, ft (m)  
 $G_1$  &  $G_2$  = Rates of grade, expressed algebraically, %

Note: ALL EXPRESSIONS TO BE CALCULATED ALGEBRAICALLY  
(Use algebraic signs of grades; grades in percent.)

1. Elevations of VPC and VPI:

$$\text{VPT ELEV.} = \text{VPI ELEV.} + \left(\frac{G_2}{100}\right)L_2 \quad \text{Equation 33-4.22}$$

$$\text{VPC ELEV.} = \text{VPI ELEV.} - \left(\frac{G_1}{100}\right)L_1 \quad \text{Equation 33-4.21}$$

2. For the elevation of any point “ $x$ ” on a vertical curve:

$$\text{CURVE ELEV.} = \text{TAN. ELEV.} \pm y \quad \text{Equation 33-4.23}$$

Where:

Left of VPI ( $x_1$  measured from VPC):

$$(a) \text{ TAN ELEV.} = \text{VPC ELEV.} + \left(\frac{G_1}{100}\right)x_1 \quad \text{Equation 33-4.24}$$

$$(b) y_1 = x_1^2 \left(\frac{L_2}{L_1}\right) \left(\frac{G_2 - G_1}{200L}\right) \quad \text{Equation 33-4.25}$$

Right of VPI ( $x_2$  measured from VPT):

$$(a) \text{ TAN ELEV.} = \text{VPT ELEV.} - \left(\frac{G_2}{100}\right)x_2 \quad \text{Equation 33-4.26}$$

$$(b) y_2 = x_2^2 \left(\frac{L_1}{L_2}\right) \left(\frac{G_2 - G_1}{200L}\right) \quad \text{Equation 33-4.27}$$

**UNSYMMETRICAL VERTICAL CURVE EQUATIONS**

Figure 33-4.K

At the VPI:

$$y = E \text{ and } x = L_1$$

$$(a) \quad \text{TAN ELEV.} = \text{VPC ELEV.} + \left( \frac{G_1}{100} \right) L_1 \text{ or} \quad \text{Equation 33-4.28}$$

$$\text{TAN ELEV.} = \text{VPT ELEV.} - \left( \frac{G_2}{100} \right) L_2$$

$$(b) \quad E = L_1 L_2 \left( \frac{G_2 - G_1}{200 L} \right) \quad \text{Equation 33-4.29}$$

3. Calculating High or Low Point on a Curve:

Note: Two answers will be determined by solving the equations below. Only one answer is correct. The incorrect answer is where  $x_T > L_1$  on the left side of the VPI or where  $x_T > L_2$  on the right side of the VPI.

- a. Assume high or low point occurs left of VPI to determine the distance,  $x_T$ , from VPC:

$$x_T = \left( \frac{L_1}{L_2} \right) \left( \frac{G_2 L}{G_1 - G_2} \right) \quad \text{Equation 33-4.30}$$

Note:

Does  $x_T > L_1$ ? If yes, this answer is incorrect and the high or low point is on the right side of the VPI. (Go to Step d. to solve for the high or low point elevation.) If no, then this is the correct answer and proceed with Steps b. and c. below.)

- b. To determine high or low point stationing (where  $x_T < L_1$ ):

$$\text{STA}_{\text{HIGH OR LOW POINT}} = \text{VPC STA.} + x_T \quad \text{Equation 33-4.31}$$

- c. To determine high or low point elevation on vertical curve (when  $x_T < L_1$ ):

$$\text{ELEV.}_{\text{HIGH OR LOW POINT}} = \text{VPC ELEV.} - \left( \frac{L_1}{L_2} \right) \left( \frac{L G_1^2}{(G_2 - G_1) 200} \right) \quad \text{Equation 33-4.32}$$

- d. If  $x_T > L_1$  from Step a., the high or low point occurs right of the VPI. Determine the distance  $x_T$  from the VPT:

$$x_T = \left( \frac{L_2}{L_1} \right) \left( \frac{G_2 L}{(G_2 - G_1)} \right) \quad \text{Equation 33-4.33}$$

- e. To determine high or low point stationing:

$$\text{STA}_{\text{HIGH OR LOW POINT}} = \text{VPT STA.} - x_T \quad \text{Equation 33-4.34}$$

- f. To determine high or low point elevation on a vertical curve:

$$\text{ELEV.}_{\text{HIGH OR LOW POINT}} = \text{VPT ELEV.} - \left( \frac{L_2}{L_1} \right) \left( \frac{L G_2^2}{(G_2 - G_1) 200} \right) \quad \text{Equation 33-4.35}$$

**UNSYMMETRICAL VERTICAL CURVE EQUATIONS**

**Figure 33-4.K**  
(Continued)

4. Vertical Curve Through Fixed Point. A vertical highway curve often must be designed to pass through an established elevation and location. For example, it may be necessary to tie into an existing side road or to clear existing structures. Figure 33-4.L provides the procedure for determining how to pass a vertical curve through a fixed point. Figure 33-4.M illustrates an example on how to use these formulas.
5. Vertical Curve Gradient Percents. Occasionally, the designer may want to determine the gradient percent of a point on a vertical curve or to determine at what location a given gradient percent occurs on the vertical curve. Figure 33-4.N provides the equations for making these determinations. Figures 33-4.O and 33-4.P provide examples of how to use these equations.
6. Vertical Curve Extension. During a reconstruction project, it may be necessary to extend an existing vertical curve to ensure that the new profile gradeline will pass through a critical point (e.g., new bridge clearance). Figure 33-4.Q provides the equations for determining the required vertical curve length extension and the new gradient. Figure 33-4.R illustrates an example on how to use these equations.
7. VPI Stationing. The designer may need to determine the VPI station between two known VPI's. Figure 33-4.S illustrates how to determine the intermediate VPI given the gradients, stations, and elevations of the other VPI's.

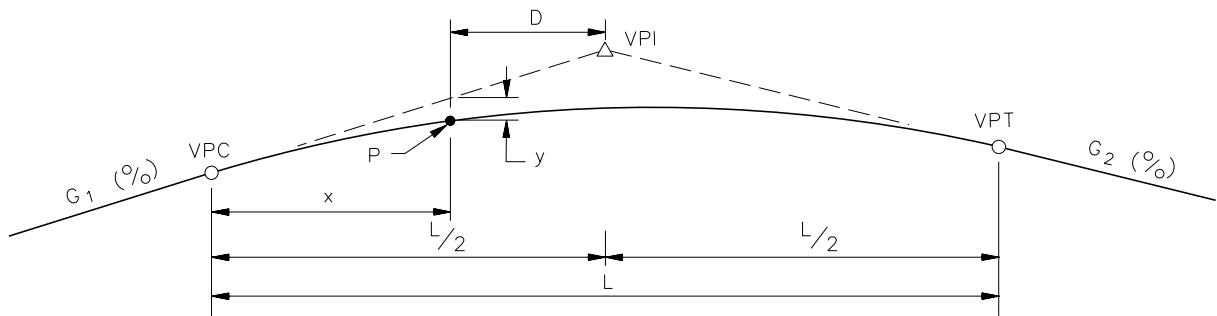

$G_1$  = Grade in, %

$G_2$  = Grade out, %

$A$  = Algebraic difference in grades, %

$y$  = Vertical curve correction at point "P", ft (m)

$x$  = Distance from VPC to "P", ft (m)

$D$  = Distance from "P" to VPI, ft (m)

$L$  = Length of vertical curve, ft (m)

**Given:**  $G_1, G_2, D$

**Problem:** Determine the length of a vertical curve required to pass through a given point (P).

**Solution:**

1. Find algebraic difference in grades:

$$A = G_2 - G_1$$

2. Find vertical curve correction at Point P:

From Equation 33-4.13 ( $x$  measured from VPC)

3. From inspection of the above diagram:

$$y = x^2 \left( \frac{G_2 - G_1}{200 L} \right)$$

$$x + D = L/2 \text{ or } L = 2(x + D)$$

Equation 33-4.36

### SYMMETRICAL VERTICAL CURVE THROUGH A GIVEN POINT

Figure 33-4.L

By substituting  $2(x+D)$  for  $L$ , and  $A$  for  $(G_2 - G_1)$  into Equation 33-4.13. Yields:

$$A x^2 + (-400 y) x + (-400 D y) = 0 \quad \text{Equation 33-4.37}$$

4. Solve for "x" using the quadratic equation:

$$x = \frac{-b \pm \sqrt{b^2 - 4ac}}{2a} = \frac{400y \pm \sqrt{160000 y^2 + 1600ADy}}{2A} \quad \text{Equation 33-4.38}$$

Solving for "X" will result in two answers. If both answers are positive, there are two solutions. If one answer is negative, it can be eliminated and only one solution exists.

5. Substitute X and D into Equation 33-4.36 and solve for L:

Note: Two positive X values, will result in two L solutions. Desirably, use the longer vertical curve solution provided it meets the sight distance criteria (based on the selected design speed and algebraic difference in grades).

## SYMMETRICAL VERTICAL CURVE THROUGH A GIVEN POINT

**Figure 33-4.L**  
(Continued)

**Example 33-4.2**

**Given:** Design Speed = 55 mph  
 $G_1 = -1.5\%$   
 $G_2 = +2.0\%$   
 $A = 3.5\%$   
VPI Station = 29 + 00.00  
VPI Elevation = 652.40 ft

**Problem:** At Station 27 + 50, a new highway must pass under the center of an existing railroad which is at elevation 679.78 ft at the highway centerline. The railroad bridge that will be constructed over the highway will be 4 ft in depth, 20 ft in width, and at right angles to the highway. Determine the length of the symmetrical vertical curve that would be required to provide a 16 ft 6 in clearance under the railroad bridge.

**Solution:**

1. Sketch the problem with known information labeled.

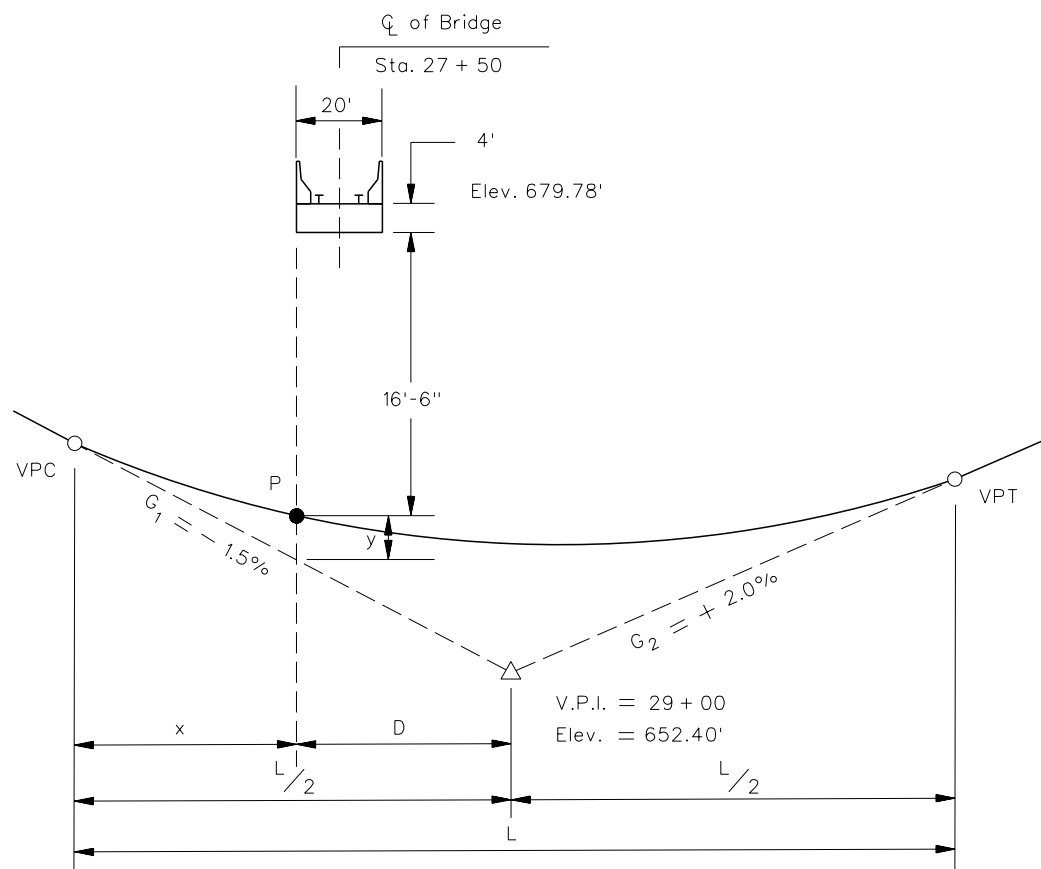

**SYMMETRICAL VERTICAL CURVE THROUGH A GIVEN POINT  
(Example 33-4.2)**

**Figure 33-4.M**

**Example 33-4.2** (continued)

2. Determine the station where the minimum 16 ft 6 in vertical clearance will occur (Point P):

*From inspection of the sketch, the critical location is on the left side of the railroad bridge.  
The critical station is:*

$$\text{STA. P} = \text{BRIDGE CENTERLINE STATION} - \frac{1}{2} (\text{BRIDGE WIDTH})$$

$$\text{STA. P} = \text{STA. 27} + 50 - \frac{1}{2} (20)$$

$$\text{STA. P} = \text{STA. 27} + 40$$

3. Determine the elevation of Point P:

$$\text{ELEV. P} = \text{ELEV. TOP RAILROAD BRIDGE} - \text{BRIDGE DEPTH} - \text{CLEARANCE}$$

$$\text{ELEV. P} = 679.78 - 4.0 - 16.5$$

$$\text{ELEV. P} = 659.28 \text{ ft}$$

4. Determine distance, D, from Point P to VPI:

$$D = \text{STA. VPI} - \text{STA. P} = (29 + 00) - (27 + 40) = 160 \text{ ft}$$

5. Determine the tangent elevation at Point P:

$$\text{ELEV. TANGENT AT P} = \text{VPI ELEV.} - \left( \frac{G_1}{100} \right) D = 652.40 - \left( \frac{-1.5}{100} \right) 160 = 654.80 \text{ ft}$$

6. Determine the vertical curve correction (y) at Point P:

$$y = \text{ELEV. ON CURVE} - \text{ELEV. OF TANGENT} = 659.28 - 654.80 = 4.48 \text{ ft}$$

7. Solve for x using Equation 33-4.38:

$$x = \frac{400(4.48) \pm \sqrt{(160000)(4.48)^2 + 1600(3.5)(160)(4.48)}}{2(3.5)}$$

$$x = 640 \text{ ft} \quad \text{AND} \quad x = -128 \text{ ft (Disregard)}$$

8. Using Equation 33-4.36, solve for L:

$$L = 2(x + D)$$

$$L = 2(640 + 160)$$

$$L = 1600 \text{ ft}$$

**SYMMETRICAL VERTICAL CURVE THROUGH A GIVEN POINT  
(Example 33-4.2)**

**Figure 33-4.M**  
(Continued)

9. Determine if the solution meets the desirable passenger car stopping sight distance for the 55 mph design speed. From Figure 33-4.E, the design K-value:

$$K = 115$$

The algebraic difference in grades:

$$A = G_2 - G_1 = (+2.0) - (-1.5) = 3.5$$

From Equation 33-4.6, determine the minimum length of vertical curve which meets the desirable stopping sight distance:

$$L_{\text{MIN}} = KA$$

$$L_{\text{MIN}} = (115) 3.5 = 402.5 \text{ ft}$$

$L = 1600 \text{ ft}$  which exceeds the design stopping sight distance.

**SYMMETRICAL VERTICAL CURVE THROUGH A GIVEN POINT  
(Example 33-4.2)**

**Figure 33-4.M  
(Continued)**

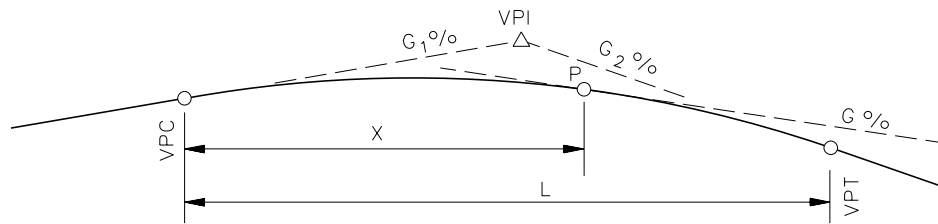

$L$  = Horizontal length of vertical curve, ft (m)

$x$  = Horizontal distance from VPC, ft (m)

$G_1$  and  $G_2$  = Rates of grade, expressed algebraically, %

1. Rate of change of vertical curve per foot:

$$a = \frac{G_2 - G_1}{L} \quad \text{Equation 33-4.39}$$

2. Gradient at a point on curve at "x" distance from the VPC:

$$G = G_1 + ax \quad \text{Equation 33-4.40}$$

3. To find the horizontal distance "x" from VPC to point of a selected gradient, use Equation 33-4.40 and solve for x:

$$x = \frac{G_1 - G}{a} \quad \text{Equation 33-4.41}$$

### FIND THE PERCENT GRADE AT ANY POINT ON A VERTICAL CURVE

Figure 33-4.N

**Example 33-4.3**

Given:  $G_1 = +2.0\%$   
 $G_2 = -3.5\%$   
 $L = 1200 \text{ ft}$

Problem: Find the gradient at a point 900 ft from the VPC.

Solution:

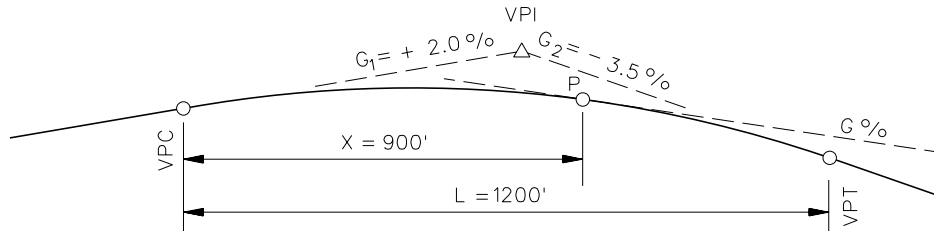

To determine the gradient at Point P, use Equations 33-4.39 and 33-4.40:

$$a = \frac{-3.5\% - 2.0\%}{1200} = -0.00458\%/ft$$

$$G = +2.0\% - 0.00458(900) = -2.125\%$$

**GRADE AT A SPECIFIC LOCATION ON A VERTICAL CURVE  
 (Example 33-4.3)**

**Figure 33-4.O**





3. Determine the distance from Point P to the vertical curve high point:

$$H = \text{Station of high point} - \text{Station of Point P}$$

4. Determine elevation difference between the vertical curve high point and Point P:

$$V = \text{Elevation of high point} - \text{Elevation of Point P}$$

5. Determine the distance from the vertical curve high point to the new VPC:

$$x_{T2} = H - \frac{\sqrt{(AH/L_1)^2 - 200(AV/L_1)}}{(A/L_1)} \quad \text{Equation 33-4.42}$$

6. Determine Station of new VPC:

$$\text{Station of new VPC} = \text{Station of high point} - x_{T2}$$

7. Determine the required new gradient:

$$G_3 = \frac{A x_{T2}}{L_1} \quad \text{or} \quad G_3 = \frac{V}{H - \frac{x_{T2}}{2}} \times 100 \quad \text{Equation 33-4.43}$$

### EXTENSION OF A VERTICAL CURVE THROUGH A POINT

**Figure 33-4.Q**  
(Continued)



Elevation of high point:

$$\text{VPC ELEV} - \left( \frac{LG_1^2}{(G_2 - G_1)200} \right) = 587.000 - \frac{1000(1)^2}{(-3 - 1)200} = 587.00 + 1.25 = 588.25 \text{ ft}$$

3. Determine the distance from Point P to the high point:

$$H = (47 + 50) - (36 + 00) = 1150 \text{ ft}$$

4. Determine the elevation difference between Point P and the high point:

$$V = 588.25 \text{ ft} - 568.50 \text{ ft} = 19.75 \text{ ft}$$

5. Determine the location of the new VPC using Equation 33-4.42:

$$X_{T2} = H - \frac{\sqrt{(AH/L_1)^2 - 200(AV/L_1)}}{(A/L_1)} = 1150 - \frac{\sqrt{\left(\frac{4 \times 1150}{1000}\right)^2 - 200\left(\frac{4 \times 19.75}{1000}\right)}}{(4/1000)}$$

$$X_{T2} = 1150 - 578.79 = 571.21 \text{ ft}$$

$$\text{New VPC}_{\text{STA}} = (47 + 50) - 571.21 = 41 + 78.79$$

6. Determine the new gradient ( $G_3$ ), using Equation 33-4.43:

$$G_3 = \frac{AX_{T2}}{L_1} = \frac{4 \times 571.21}{1000} = +2.285\%$$

**EXTENSION OF A VERTICAL CURVE THROUGH A POINT  
(Example 33-4.5)**

**Figure 33-4.R**  
(Continued)

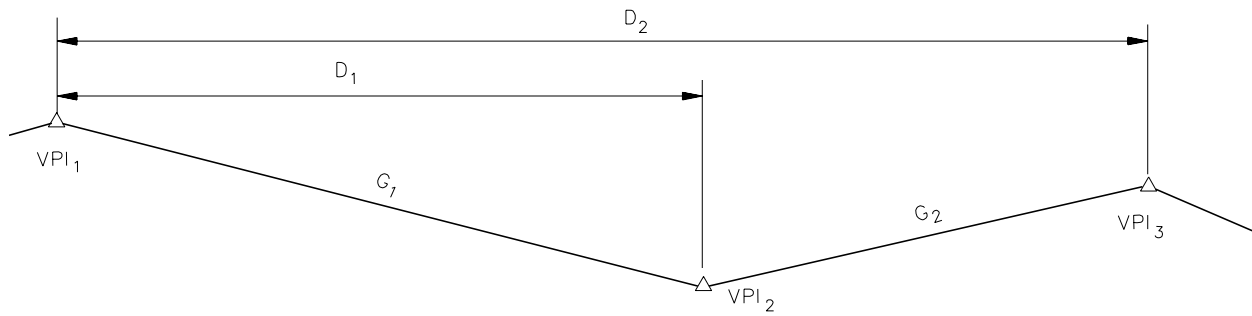

$D_1$  = Distance between  $VPI_1$  and  $VPI_2$ , ft  
 $D_2$  = Distance between  $VPI_1$  and  $VPI_3$ , ft

Given: Station and Elevation at  $VPI_1$   
 Station and Elevation at  $VPI_3$   
 $G_1, G_2$  (%)

Problem: Find Station and Elevation of  $VPI_2$ .

Solution:

1. Find the station of  $VPI_2$ :

$$D_1 = \frac{(\text{ELEV. } VPI_3 - \text{ELEV. } VPI_1) - G_2 D_2}{G_1 - G_2} \quad \text{Equation 33-4.44}$$

$$\text{STA. } VPI_2 = \text{STA. } VPI_1 + D_1$$

2. Find the elevation of  $VPI_2$ :

$$\text{ELEV. } VPI_2 = \text{ELEV. } VPI_1 + G_1 D_1 \quad \text{Equation 33-4.45}$$

**VERTICAL CURVE COMPUTATION  
 (Intermediate VPI)**

**Figure 33-4.S**

**33-5 VERTICAL CLEARANCES**

Chapters 44 through 48 present the minimum roadway vertical clearances for new construction and reconstruction projects and the minimum clearances for structures allowed to remain-in-place. Chapter 49 provides the roadway vertical clearances for 3R projects on non-freeways. Chapter 50 provides the roadway vertical clearances for 3R freeway projects. Chapter 39 provides typical sections for highway underpasses and illustrates where to measure vertical clearances. In addition to the criteria presented in these chapters, consider the following:

1. Pedestrian Bridges/Sign Trusses. See Chapters 44 through 50 for the minimum vertical clearance under pedestrian bridges and sign trusses.
2. Traffic Signals. On all new or reconstruction projects, provide a minimum vertical clearance of 16 ft 6 in (5.0 m) with a maximum clearance of 18 ft 0 in (5.5 m). For 3R projects, a vertical clearance of 14 ft 9 in (4.5 m) may be allowed to remain-in-place. Consult with the Bureau of Operations for additional guidance. Measure this clearance from the roadway surface to the bottom of the signal housing or to the bottom of the back plate.
3. Railroads. See Chapters 44 through 50 and Section 39-4.03 for the minimum vertical clearance over railroads.



### 33-6 DESIGN PRINCIPLES AND PROCEDURES

#### 33-6.01 General Controls for Vertical Alignment

As discussed elsewhere in Chapter 33, the design of vertical alignment involves, to a large extent, complying with specific limiting criteria. These include maximum and minimum grades, sight distance at vertical curves, and vertical clearances. In addition, the designer should adhere to certain general design principles and controls which will determine the overall safety and operation of the facility and will enhance the aesthetic appearance of the highway. These design principles for vertical alignment include:

1. Consistency. Use a smooth gradeline with gradual changes, consistent with the type of highway and character of terrain, rather than a line with numerous breaks and short lengths of tangent grades.
2. Coordination with Natural/Man-Made Features. The vertical alignment should be properly coordinated with the natural topography, available right-of-way, utilities, roadside development, and natural/man-made drainage patterns. This is especially important in rugged terrain.
3. Roller Coaster. Avoid a “roller-coaster” type of profile, especially where the horizontal alignment is relatively straight. This type of profile may be proposed in the interest of the economy, but it is aesthetically undesirable and may be hazardous. To avoid this type of profile, incorporate into the design horizontal curvature and/or flatter grades that may require greater excavations and higher embankments.
4. Broken-Back Curvature. Avoid “broken-back” gradelines (two crest or sag vertical curves separated by a short tangent). This alignment is particularly noticeable on divided highways with open-ditch median sections. One long vertical curve is more desirable. In rural areas, any distance less than 1500 ft (500 m) between VPI’s is considered to be a broken-back profile.
5. Long Grades. On a long ascending grade, it is preferable to place the steepest grade at the bottom and flatten the grade near the top. It is also preferable to break the sustained grade with short intervals of flatter grades. Evaluate substantial lengths of grades for their effect on traffic operations (e.g., trucks).
6. Sags. Avoid sag vertical curves in cuts unless adequate drainage can be provided. Also, to avoid drainage problems on bridges, do not place the low point of sag vertical curves on a bridge.
7. Intersections. Maintain moderate grades through intersections to facilitate braking and turning movements. See Chapter 36 for specific information on vertical alignment through intersections.
8. Environmental Impacts. Vertical alignment should be properly coordinated with environmental impacts. However, the safety of the highway should not be compromised.

### **33-6.02 Coordination of Horizontal and Vertical Alignment**

Do not design the horizontal and vertical alignments independently. Instead they should complement each other. This is especially true for new construction projects. Poorly coordinated designs can detract from the benefits and emphasize the deficiency of each alignment. A thorough study of the alignment is always warranted.







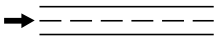
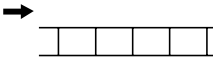
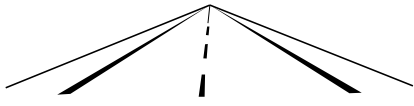
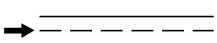

Horizontal alignments and vertical profiles are among the most important permanent design elements for a highway. Excellence in their design and coordination increases the highway's utility and safety, encourages uniform speeds, and can greatly improve the highway's appearance. This usually can be accomplished with little additional costs. The designer should coordinate the layout of the horizontal and vertical alignment as early as practical in the design process. Alignment layouts are typically completed after the topography and ground line have been drafted. Use the computer visualization program within CADD (e.g., GEOPAK) to visualize how the layout will appear in the field. Review several alternatives to ensure that the most pleasing and practical design is selected.

It is difficult to discuss the combination of horizontal alignment and vertical profile without reference to the broader subject of highway location. The subjects are mutually interrelated and what may be said about one generally is applicable to the other. The physical controls or influences that act singularly or in combination that determine the type of alignment are:

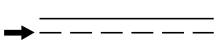
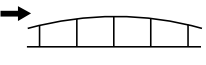
- the character of highway, justified by traffic volumes;
- topography and subsurface conditions;
- existing highway and cultural developments;
- likely future developments; and
- suitable locations for intersections and interchanges.

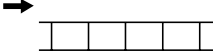
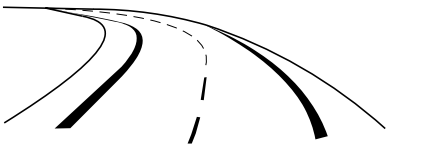
Figures 33-6.A through 33-6.E illustrate poor and preferred examples of horizontal and vertical alignment coordination. In addition, consider the following when coordinating horizontal and vertical alignment on rural and suburban highways:

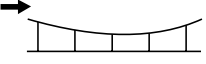
1. **Balance.** Horizontal curvature and grades should be in proper balance. Maximum curvature with flat grades or flat curvature with maximum grades does not achieve this desired balance. A compromise between the two extremes produces the best design relative to safety, capacity, ease, uniformity of operations, and aesthetics.
2. **Coordination.** Vertical curvature superimposed upon horizontal curvature (i.e., vertical and horizontal P.I.'s at approximately the same stations) generally results in a more pleasing appearance and reduces the number of sight distance restrictions. Successive changes in profile, not in combination with horizontal curvature, may result in a series of humps visible to the driver for some distance, which may produce an unattractive design. However, under some circumstances, superimposing the horizontal and vertical alignment must be tempered somewhat by Items 3 and 4 below.

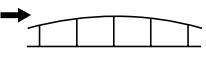
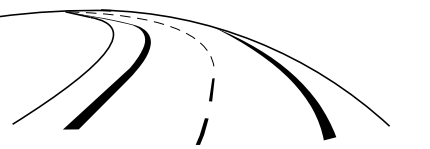
Horizontal Design Element	Vertical Design Element	Three Dimensional Design Element
 <p>Tangent</p>	 <p>Tangent</p>	 <p>Tangent with Constant Gradeline</p>
 <p>Tangent</p>	 <p>Sag Curve</p>	 <p>Tangent with Sag Vertical Curve</p>
 <p>Tangent</p>	 <p>Crest Curve</p>	 <p>Tangent with Crest Vertical Curve</p>
 <p>Curve</p>	 <p>Tangent</p>	 <p>Horizontal Curve with Constant Gradeline</p>
 <p>Curve</p>	 <p>Sag Curve</p>	 <p>Horizontal Curve with Sag Vertical Curve</p>
 <p>Curve</p>	 <p>Crest Curve</p>	 <p>Horizontal Curve with Crest Vertical Curve</p>

**HORIZONTAL AND VERTICAL ALIGNMENT COORDINATION**

**Figure 33-6.A**

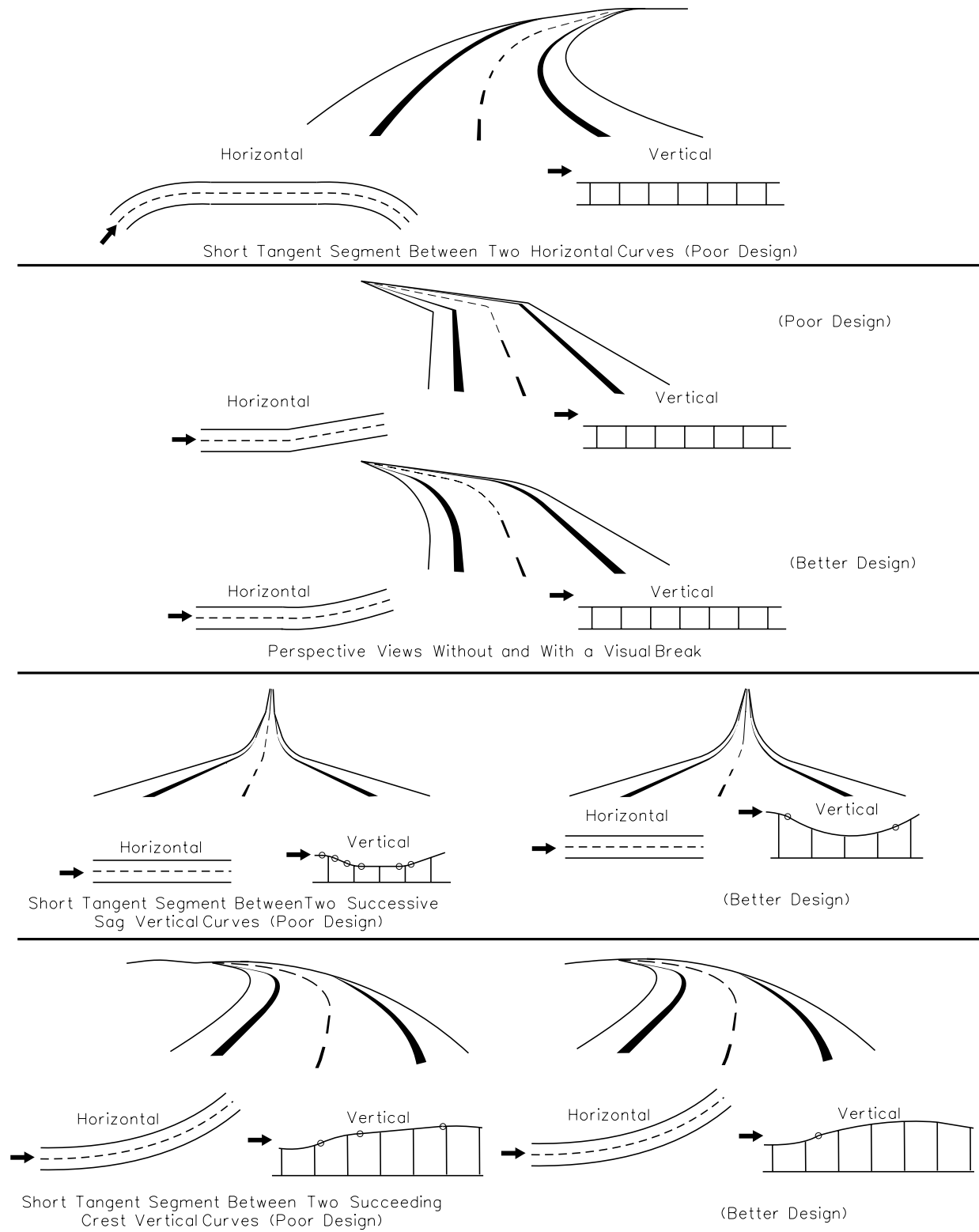

**EXAMPLES OF UNDESIRABLE AND GOOD ALIGNMENT COORDINATION**

**Figure 33-6.B**

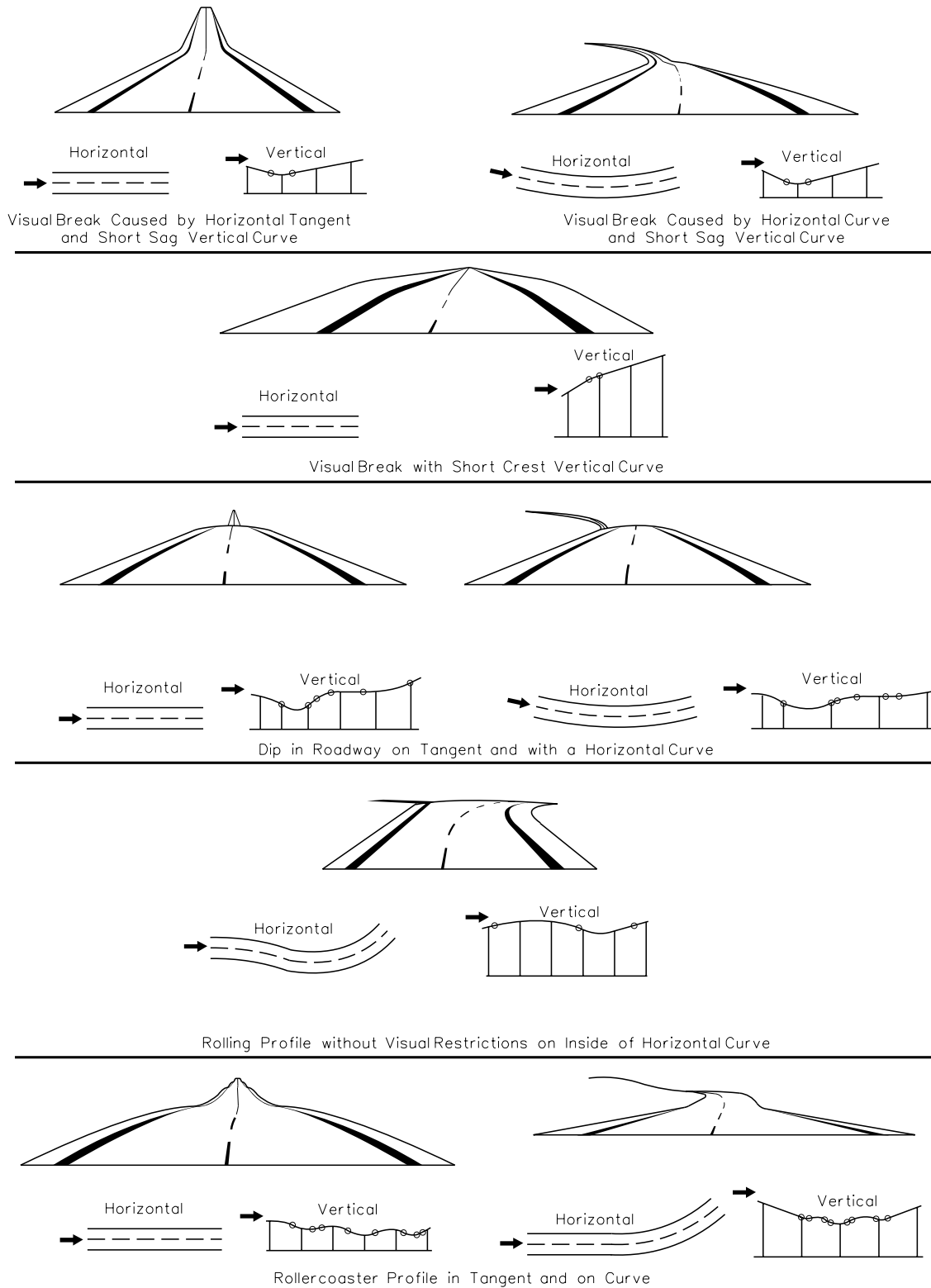

**COMBINED ALIGNMENT DESIGNS TO AVOID**

**Figure 33-6.C**

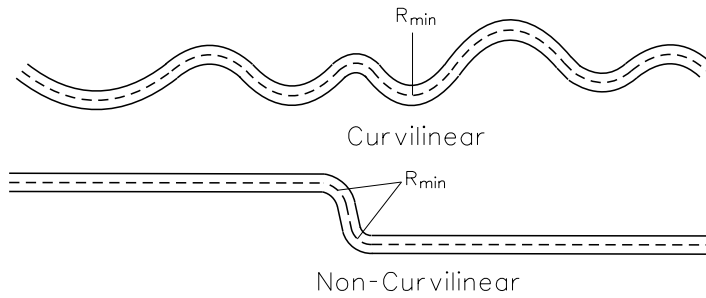

a) Horizontal Alignments

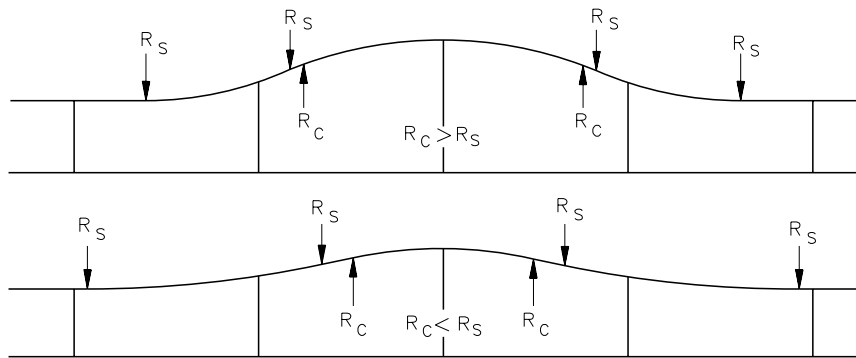

$R_S$  = Radius (Sag)  
 $R_C$  = Radius (Crest)  
 Where  $R \approx 300K$  (100K)  
 and  $K$  is defined as sharpness of vertical curve or  $L = KA$

b) Vertical Alignments: (Relation  $R_C : R_S$ )

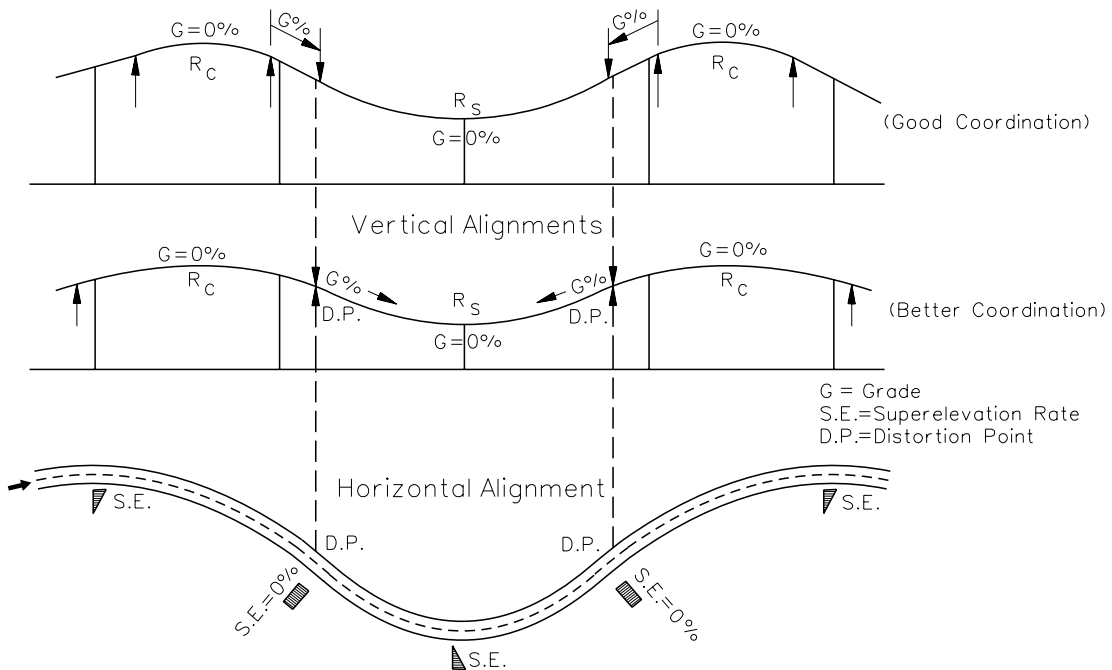

$G$  = Grade  
 $S.E.$  = Superelevation Rate  
 $D.P.$  = Distortion Point

c) Coordination of Distortion Points in Horizontal and Vertical Alignments

**SUPERIMPOSITION OF HORIZONTAL AND VERTICAL ALIGNMENTS**

**Figure 33-6.D**

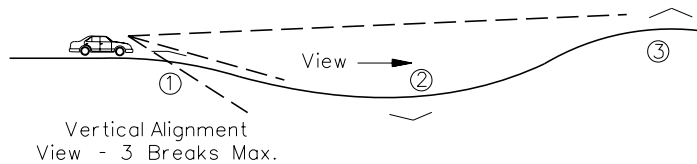
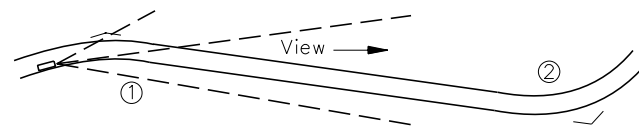
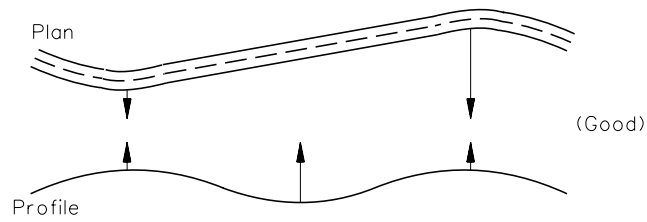
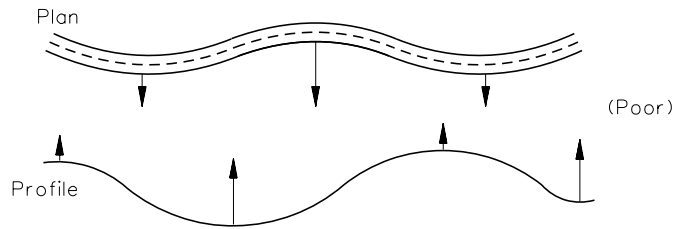
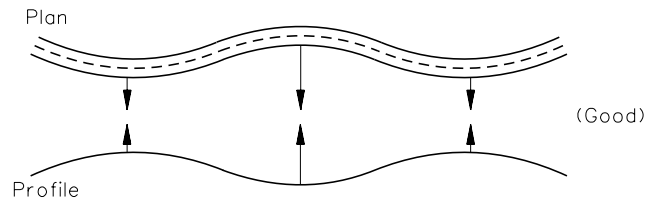

**EXAMPLES OF SUPERIMPOSITION OF HORIZONTAL AND VERTICAL ALIGNMENTS**

**Figure 33-6.E**

3. Crest Vertical Curves. Do not introduce sharp horizontal curvature at or near the top of pronounced crest vertical curves. This is undesirable because the driver cannot perceive the horizontal change in alignment, especially at night when headlight beams project straight ahead into space. This problem can be avoided if the horizontal curvature leads the vertical curvature or by using design values which well exceed the minimums.
4. Sag Vertical Curves. Do not introduce sharp horizontal curves at or near the low point of pronounced sag vertical curves or at the bottom of steep grades. Because visibility to the road ahead is foreshortened, only flat horizontal curvature will avoid an undesirable, distorted appearance. At the bottom of long grades, vehicular speeds often are higher, particularly for trucks, and erratic operations may occur, especially at night and during icy conditions.
5. Passing Sight Distance. In some cases, the need for frequent passing opportunities and a higher percentage of passing sight distance may supersede the desirability of combining horizontal and vertical alignment. In these cases, it may be necessary to provide long tangent sections to secure sufficient passing sight distance.
6. Intersections. At intersections, horizontal and vertical alignment should be as flat as practical to provide a design which produces sufficient sight distance and gradients for vehicles to slow, stop, or turn; see Chapter 36.
7. Divided Highways. On divided facilities with wide medians, it is frequently advantageous to provide independent alignments for the two one-way roadways. Where traffic volumes justify a divided facility, and where rolling or rugged terrain exists, a superior design can result from the use of independent alignments and profiles.
8. Residential Areas. For highways near subdivisions, design the alignment and profile to minimize nuisance factors to neighborhoods. For freeways, a depressed facility can make the highway less visible and reduce the noise to adjacent residents. Also, for all highway types, minor adjustments to the horizontal alignment may increase the buffer zone between the highway and residential areas.

### **33-6.03 Aesthetics**

The coordination of the horizontal and vertical alignment should be designed to enhance the aesthetics of the facility. A proper layout as discussed in Section 33-6.02 will generally provide an attractive facility. In addition, the designer should consider the effect the cross section will have on the facility's aesthetics. The following sections present several ideas that may enhance the attractiveness of a facility.

**33-6.03(a) General**

A major problem may develop with the layout of a new highway if the designer attempts to superimpose a linear roadway configuration onto nonlinear land forms. A properly developed alignment will reduce driver monotony, provide a positive visual experience, and integrate the roadway into the landscape without providing unsightly visual impacts. To accomplish this, design the vertical and horizontal alignment to:

- fit the landscape with minimal land form modifications;
- enhance the area's landscape character;
- direct the driver's attention to positive visual features in the landscape (e.g., the highway should lead into, rather than away from those views considered aesthetically pleasing); and
- capitalize on other opportunities that will create a pleasant visual experience (e.g., the roadway should descend towards those features of interest at a low elevation and rise toward those features which are best viewed from below or in silhouette against the sky).

Often the use of various impact reduction methods described in the following sections are in conflict with each other (e.g., slope rounding versus vegetation retainage). To resolve these conflicts, the designer must determine for whom the visual impact reductions are made (e.g., the driver, local residents, tourists). Some of the factors that should be considered include the:

- number of potential viewers;
- location of the viewer;
- duration of the view (length and number of times the view is seen);
- type of potential viewers (tourists, local residents, pass-throughs);
- type of area from which it is viewed (recreational areas, farms, major highways, urban); and
- other focal points that will draw attention from the road.

The designer should use the Department's computerized visualization CADD program (i.e., GEOPAK) to review the design from both the perspective view of the driver and the perspective view from outside the roadway.

**33-6.03(b) Rural Visual Impacts**

One of the goals of producing an aesthetically pleasing design is to reduce the visual impact the roadway has on the landscape. The following presents several ideas for reducing this impact:

1. Horizontal and Vertical Alignment Coordination. Properly coordinated horizontal and vertical alignments can lead to aesthetically pleasing designs. Section 33-6.02 discusses the coordination of the vertical and horizontal alignments.
2. Cut and Fill Slopes. Explore possible alternatives that will reduce the magnitude of exposed cut and fill slopes. Some of these alternatives include moving the alignment slightly or changing the geometric design through a specific area. For example, reducing the ditch width by 3 ft (1.0 m) and increasing the slope rates, say, for 3000 ft (1000 m) on the project may significantly reduce the amount of exposed cut slope and thereby enhance the visual impact of the facility on the landscape. Figure 33-6.F illustrates examples of poor and good alignments for reducing exposed cut and fill slopes.
3. Reducing Earthwork Modifications. Once measures have been adopted to reduce the magnitude of exposed cut and fill slopes, additional earthwork modifications can be used to further improve visual impacts. Some of these modifications include:
  - a. Slope Rounding. Slope rounding allows the fill and cut slopes to blend naturally into the existing landscape. It reduces the sharp, unnatural edges formed by the junction of a constant pitch cut or fill slope with the naturally rounded landscape. Figure 33-6.G illustrates an example of slope rounding.
  - b. Warping Slopes. Warping slopes allows the designer to vary the slope pitch to more closely match the surrounding land form and to present a more natural landscape.
  - c. Waste Materials. Positive utilization of waste materials can enhance the visual impacts of the facility. On freeways and expressways with independent alignments, contrasts can be reduced by creating low-earth mounds or by filling unnatural looking depressions.
4. Color. Freshly cut rock faces often produce very sharp contrasts to the surrounding landscape. "Aging" the rock cut or fill slope can be accomplished with replanting vegetation or by covering the rock cut or fill slope with asphalt emulsions, paints, etc.
5. Texture. Rock cuts should be textured to match the local rock faces. This may require using smooth cuts or broken-face cuts. Broken-face cuts also provide pockets which allow for a more rapid natural revegetation of the face. Another way to provide texture is to scarify cut slopes. A random pattern of scarification is the most desirable.
6. Vegetation. One of the easiest ways to reduce the visual impact of the roadway is to retain as much of the existing vegetation and riparian habitat as practical. Figure 33-6.H illustrates an example of the advantages of retaining vegetation. However, retaining vegetation is often limited by roadside safety factors, sight distance requirements, the desire to open views and vistas (see Figure 33-6.I), construction requirements, maintenance requirements, etc.

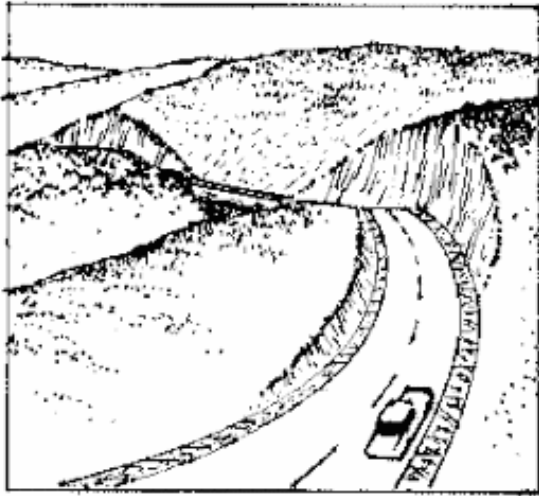

POOR VISUAL EFFECT

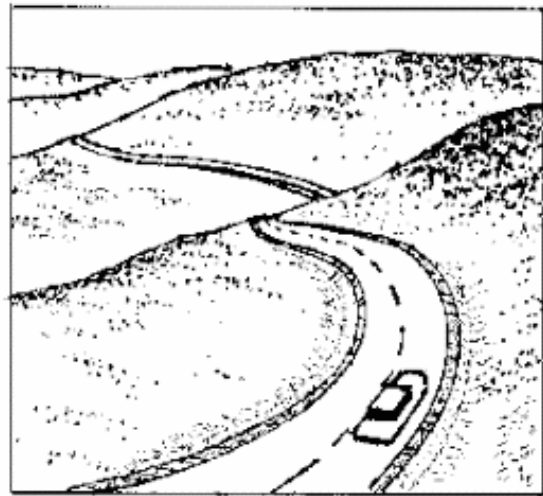

GOOD VISUAL EFFECT

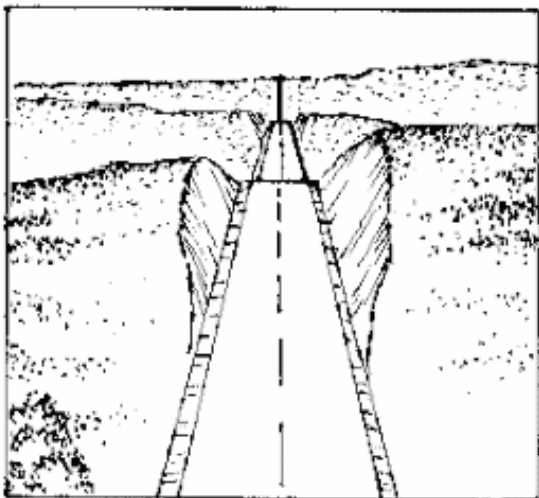

POOR VISUAL EFFECT

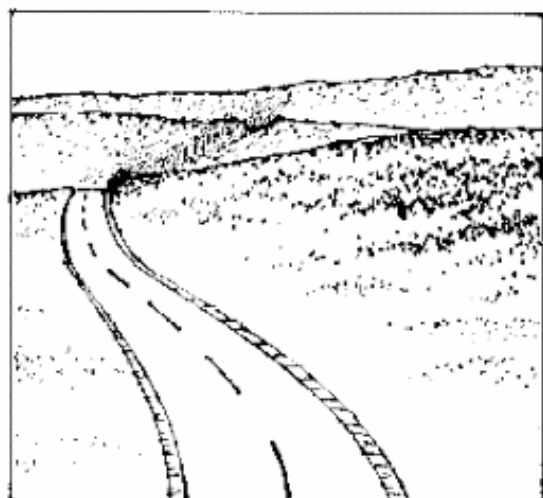

GOOD VISUAL EFFECT

**ALIGNMENT EFFECTS ON FILL AND CUT SLOPES**

**Figure 33-6.F**

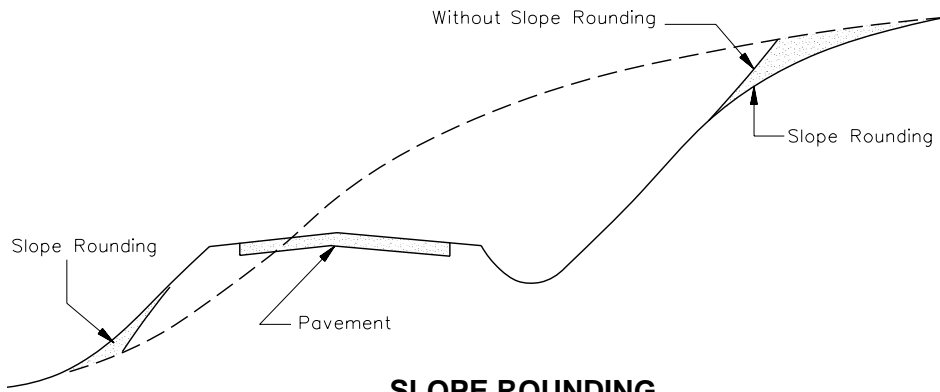

**SLOPE ROUNDING**

**Figure 33-6.G**

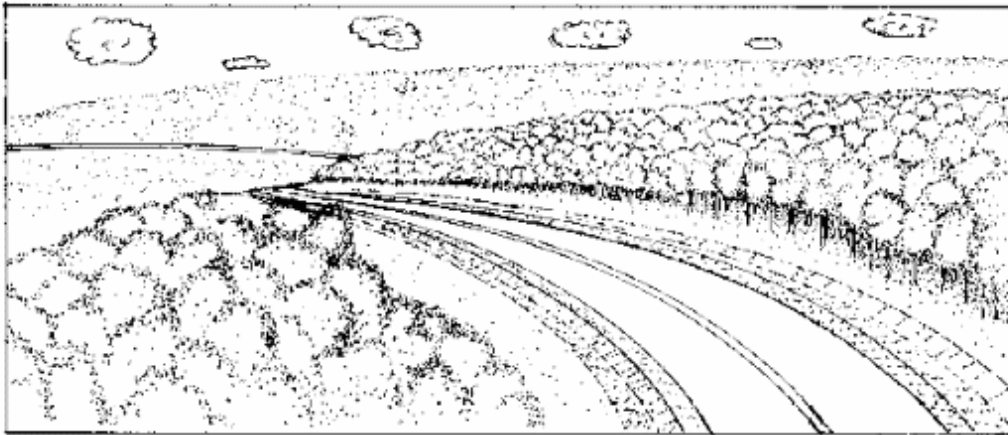

POOR VISUAL EFFECT

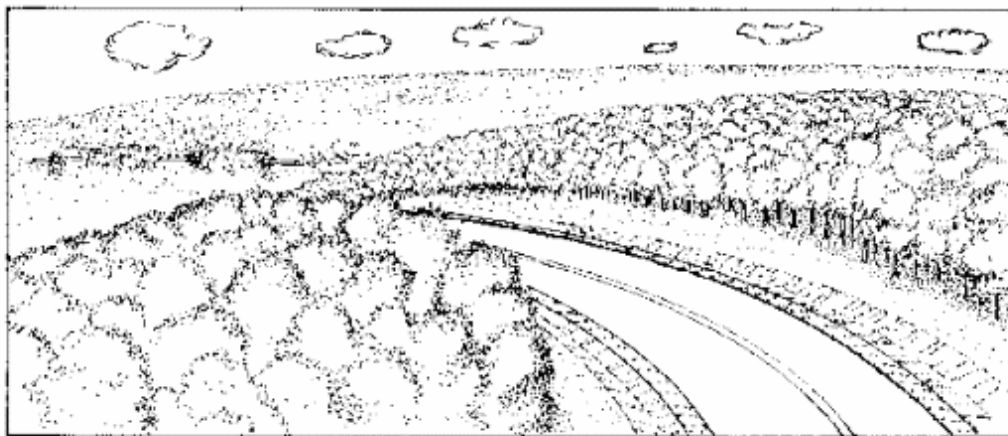

GOOD VISUAL EFFECT

**DISAPPEARING FOCAL POINT AND VEGETATION RETAINAGE**

**Figure 33-6.H**



**SELECTIVE THINNING**

Figure 33-6.I

Wildflowers can significantly improve the roadway aesthetics with minimal effort and may reduce the roadside maintenance requirements. Freeway medians, interchanges, and large open roadside areas are common locations for wildflowers. Give special attention to selecting the color, texture, soil conditions, and flower types to ensure successful plantings.

7. Daylighting. Daylighting can be used to open the roadway to broad panoramic views which otherwise may be hidden by cuts. However, do not use daylighting if the desire is to hide the road from other viewers or if the desire is to retain the existing vegetation and wildlife habitat.

### **33-6.03(c) Urban Visual Impacts**

Generally, it is more difficult to obtain aesthetically pleasing designs in urban areas due to limited right-of-way, limited design options, and competing distractions. However, as practical, the designer should work with local officials to produce an aesthetically pleasing design. The following presents several options for improving the visual impact of roadways in urban areas:

1. Structures. Structure aesthetics do not necessarily require ornamentation or decoration. However, giving special attention to scale, proportion, form, line, material, texture, color, and other principles of art and architecture can produce aesthetically pleasing structures. Also, consider views from bridges. For example, views of rivers, lakes, or city centers from high bridges can often present spectacular views.
2. Medians. Because of right-of-way restrictions in urban areas, the use of wide medians on arterial streets are seldom practical. However, raised-curb or depressed medians in the suburban areas may allow some type of landscaping in the median. Where landscaping is proposed, ensure that it will not affect the roadside safety or restrict sight distances.
3. Sound Walls. On many urban freeways and expressways, sound walls are an integral part of the highway cross section. However, sound walls can often produce a tunnel-like effect. To reduce this effect, give special consideration to changing the alignment and profile of the wall. This can be accomplished by changing material types and texture, stepping the top of the wall, providing curvilinear designs, and providing plantings along the wall. Also, give special care to adjacent properties behind the wall to ensure satisfied property owners.
4. Grading. Use of contour grading on urban freeways and expressways can significantly reduce the highway impact on the surrounding area. Figure 33-6.J illustrates a good contour grading plan at an interchange. In addition, lowering urban freeways below grade can often reduce the noise and visual impacts of the highway to nearby neighborhoods.

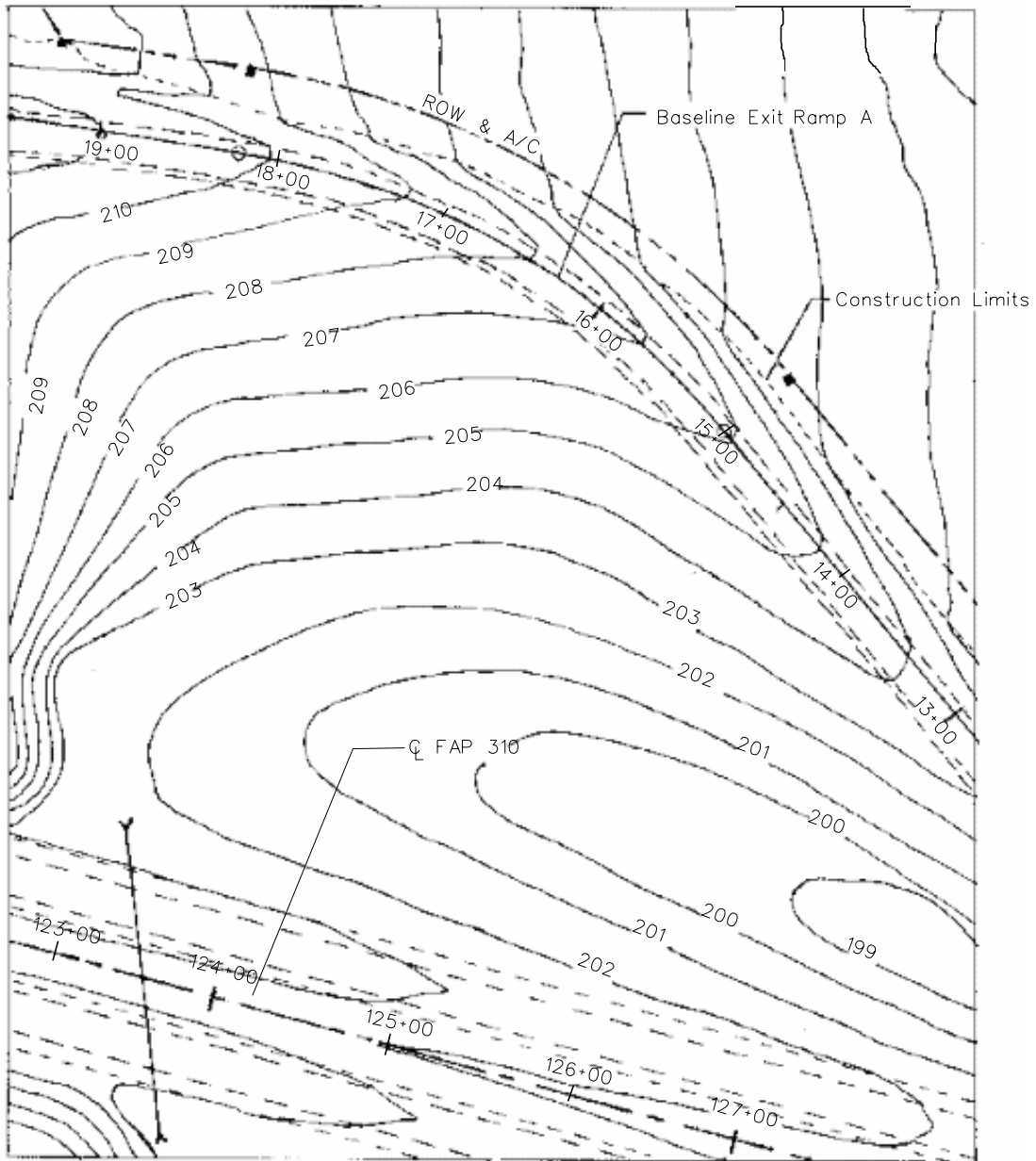

**CONTOUR GRADING  
(US Customary)**

**Figure 33-6.J**

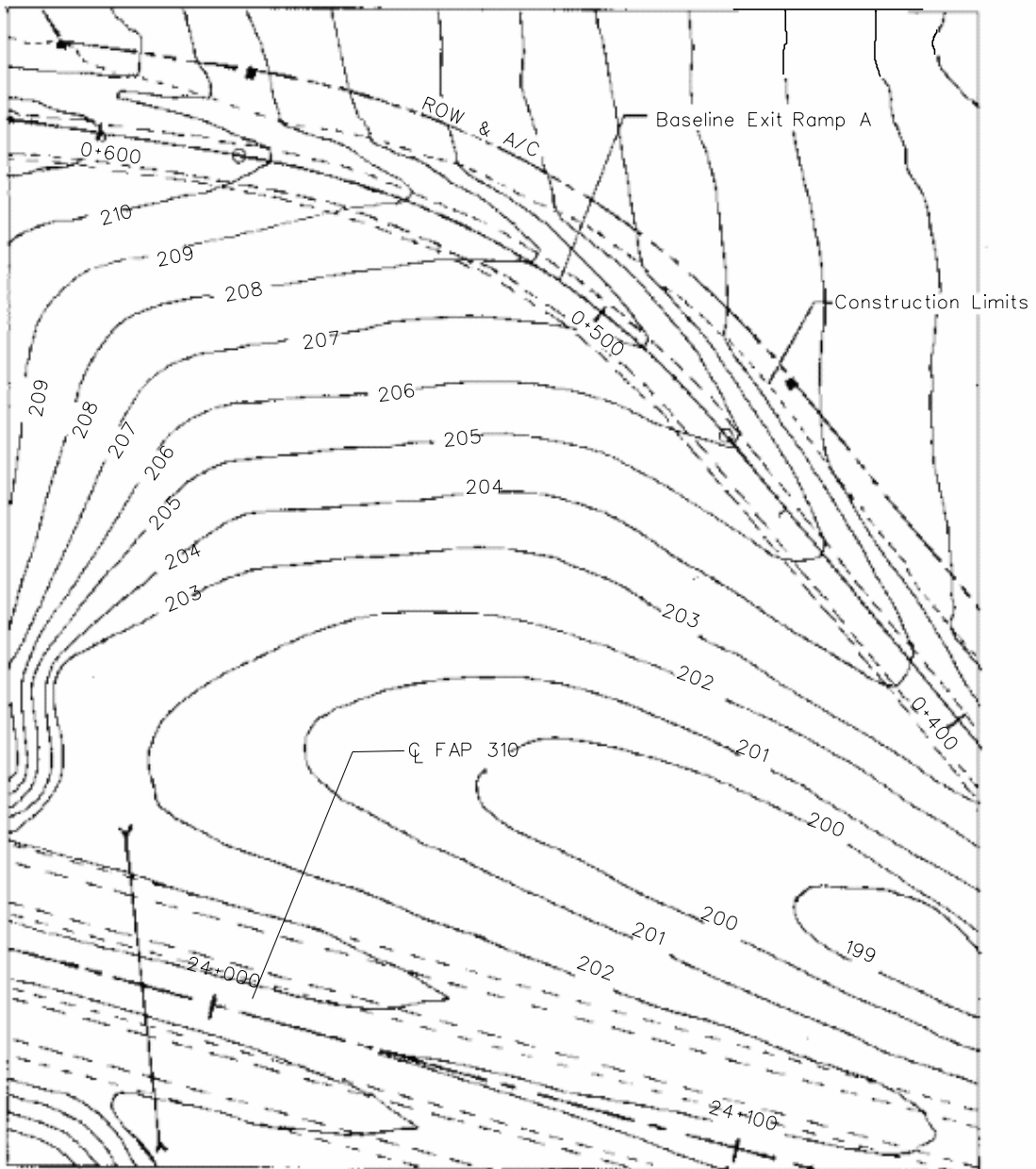

**CONTOUR GRADING  
(Metric)**

**Figure 33-6.J**

5. Sidewalks and Other Amenities. The use of varied sidewalk widths, material types, and street furniture can significantly improve the appearance of the urban street. Traffic signals, luminaires, benches, planting boxes, ornamental trees, bus stops, etc., can be artistically designed to meet the local decor and to improve the streets' visual impact on the surrounding neighborhood. These elements should be coordinated with the municipalities with appropriate agreement on cost-sharing. For additional guidance, see Chapters 5, 17, and 48.
6. Bicycle Facilities. In addition to increasing the safety of bicyclists, separate bicycle facilities often allow the designer to enhance the roadside aesthetics by providing additional room for plantings, aesthetically pleasing barriers, etc. Chapter 17 provides additional information on bicycle facilities.
7. Utilities. Desirably, place all utilities underground. This removes unsightly poles and lines and generally improves the safety of the urban facility. However, because of installation costs and limited right-of-way, this option may not always be practical.

### **33-6.04 Design of Profile Gradelines**

#### **33-6.04(a) General**

The profile gradeline of a highway typically has the greatest impact on a facility's cost, aesthetics, safety, and operation. The profile is a series of tangent lines connected by parabolic vertical curves. It is typically placed along the roadway centerline of undivided facilities and at the two median edges of the traveled way on divided facilities.

The designer must carefully evaluate many factors when establishing the profile gradeline of a highway. These include:

- maximum and minimum gradients;
- sight distance criteria;
- earthwork balance;
- location of bridges and drainage structures;
- high-water levels (flood frequency);
- drainage considerations;
- water table elevations;
- location of highway intersections and interchanges;
- snow drifting;
- frost penetration;
- highway/railroad crossings;
- types of soil;
- adjacent land use and values;
- highway safety;
- coordination with other geometric features (e.g., the cross section);
- topography/terrain;

- truck performance;
- available right-of-way;
- type and location of utilities;
- urban/rural location;
- aesthetics/landscaping;
- construction costs;
- environmental impacts;
- driver expectations;
- airport flight paths (e.g., grades and lighting); and
- pedestrian and disabled accessibility in urban areas.

The following sections discuss the establishment of the profile gradeline in more detail. Section 11-5.04(d) discusses the procedures for establishing the profile gradeline during Phase I studies.

### **33-6.04(b) Design of Urban Profile Gradelines**

Laying out profile gradelines in urban areas often is more complicated than in rural areas due to limited right-of-way, closely spaced intersections, existing roadside development, and accommodation of drainage on curbed streets including drainage from outside the street. Evaluate the following factors when developing a profile gradeline on an urban project:

1. Vertical Curves. Long vertical curves on urban streets are generally impractical. The designer will typically need to lay out the profile gradeline to meet existing field conditions. Therefore, the minimum vertical curve lengths generally are provided on urban streets. Where practical, locate VPI's at or near the centerlines of cross streets. For flat urban areas where the algebraic difference in grades is between 0.6% and 1%, use the minimum length of sag or crest curve as discussed in Sections 33-4.01(a) and 33-4.02(b) (i.e.,  $L = 3V$  ( $L = 0.6V$ )). At signalized and stop-controlled intersections, some flattening of the approaches also may be required for better traffic operations.
2. Surface Drainage. Urban streets will usually have curbs and gutters, which may complicate the layout of the profile gradeline to facilitate drainage. Take special care to avoid flat spots where water may pond, especially through radius returns. Section 33-2 provides the minimum gradients for curbed streets. In very flat areas, the profile gradeline may be rolled up and down at 0.3% to 0.5% to provide the necessary drainage. Also, see the *IDOT Drainage Manual* for guidance on encroachment of water onto the traveled way. At intersections, the surface drainage preferably should be intercepted upstream of an intersection.
3. Spline Curves. Spline curves can be helpful in laying grades in urban areas where it is necessary to meet numerous elevation restrictions in relatively short distances. Spline curves are thin, flexible pieces of plastic that can be bent into any curved shape. The designer will need to tie these curves to the profile gradeline at the beginning and end. Show the elevations along a spline curve at 20 ft (5 m) intervals.

4. Existing Roadside Development. Where roadside development is extensive, the cross-section design of a curb and gutter street is critical. Ensure adequate drainage is provided behind curbs, that the profiles for existing driveways are acceptable, and that sidewalk elevations match existing development in built-up areas.
5. Earthwork Balance. Balancing earthwork is typically impractical in urban areas; see Section 33-6.04(g). An excess of excavation is preferable to the need for borrow, due to the generally higher cost of borrow in urban areas. The designer should account for excavation from storm sewer installation when suitable soil is available.
6. Underground Utilities. On existing streets, ensure that any change in the profile gradeline will still provide the minimum coverage for utilities. For additional guidance on minimum utility clearances, see Chapter 6.
7. Limited Right-of-Way. Careful consideration is warranted when substantially lowering or raising the profile gradeline. This will often result in more right-of-way impacts (e.g., steeper driveways, removing parking, reducing front lawns, adding retaining walls).

#### **33-6.04(c) Design of Rural Profile Gradelines**

When developing rural profile gradelines, the designer should review the following sections:

- Section 11-5.04(d) for the procedures of establishing the profile gradeline,
- Section 33-6.01 for the general controls for vertical alignment, and
- Section 33-6.02 for the coordination of horizontal and vertical alignments.

#### **33-6.04(d) Soils**

The type of earth material encountered often influences the profile gradeline at certain locations. For example, if rock is encountered, it may be more economical to raise the gradeline and reduce the rock excavation. Soils that are unsatisfactory for embankment or cause a stability problem in cut areas may also be determining factors in establishing the profile gradeline.

During Phase I studies, review the preliminary Geotechnical Report before determining the final profile gradeline. The Geotechnical Report describes the effects soils and geology may have on the selected profile gradeline. Figure 33-6.K can be used to determine the effected various profiles and roadway designs may have on subsurface drainage and, subsequently, pavement performance. To reduce possible stability problems, coordinate the development of the profile gradeline with the district materials staff during Phase I and again during the preparation of construction plans in Phase II. For more detailed information on soils, see the *Geotechnical Manual*.



**33-6.04(e) Drainage/Snow**

Proper placement of the pavement structure above the surrounding topography in rural areas can significantly enhance the life and serviceability of the roadway. Consequently, the profile gradeline should be compatible with the roadway drainage design and should minimize snow drifting problems. Consider the following:

1. **Culverts.** The roadway elevation should meet the Department criteria for minimum cover at culverts and minimum freeboard above the headwater level at culverts. See the *IDOT Drainage and Culvert Manuals* for more information on the hydraulic and structural design of culverts, respectively.
2. **Coordination with Geometrics.** The profile gradeline must reflect compatibility between drainage design and roadway geometrics. These include the design of sag and crest vertical curves, spacing of inlets on curbed facilities, impacts on adjacent properties, superelevated curves, intersection design elements, and interchange design elements. For example, avoid placing sag vertical curves in cuts or placing long crest vertical curves on curbed pavements or on bridges.
3. **Snow Drifting.** Where practical, in level terrain, the profile gradeline should be at least 3 ft (1.0 m) above the natural ground level to prevent snow from drifting onto the roadway and to promote snow blowing off the roadway. Slope rounding and tree planting adjacent to the right-of-way line may also help to prevent drifting in cut areas. For additional guidance, see the SHRP publication *Design Guidelines for the Control of Blowing and Drifting Snow*.
4. **Water Tables.** Establish the profile gradeline so that the top of the subgrade elevation is not less than 3 ft (1.0 m) above the water table at all points along any cross section within the paved roadway surface. The elevation of the water table is typically documented in the Geotechnical Report. If it is not practical to provide the 3 ft (1.0 m) clearance, coordinate the profile design with the District Studies and Plans Engineer and the District Geotechnical Engineer to develop an alternative solution.
5. **Frost Penetration.** The minimum embankment height should not be less than the anticipated maximum depth of frost penetration, unless the drainage classification of the underlying soil is rated "good" as described in Figure 33-6.K. However, if the roadway is essentially at ground level, this could cause a problem. In cut sections or with shallow embankments, the roadside ditch depth should be equal to the expected maximum level of frost penetration but not less than 3 ft (1.0 m).
6. **Flooding.** For highways within a floodplain area and which have a DHV of 100 or more, the profile gradeline should be at least 3 ft (1.0 m) higher than the high water mark for the design flood frequency. For flood frequencies to be used on highways, review the *IDOT Drainage Manual* and Chapter 39 of the *BDE Manual*.

**33-6.04(f) Erosion Control**

To minimize erosion, consider the following relative to the profile gradeline:

- Minimize the number of deep cuts and high fill sections.
- On high fill sections (e.g., over railroads where 1V:2H slopes are used), provide a mountable curb at the edge of shoulder to collect the drainage.
- Conform the highway to the contour and drainage patterns of the area.
- Use natural land barriers and contours to channelize runoff and confine erosion and sedimentation.
- Minimize the amount of disturbance.
- Preserve and use existing vegetation.
- Reduce the slope length by benching and ensure that erosion is confined to the right-of-way and does not deposit sediment on or erode away adjacent lands.
- Avoid locations having high erosion potential (e.g., loess soils).
- Avoid cut or fill sections in seepage areas.

**33-6.04(g) Earthwork Balance**

Where practical and where consistent with other project objectives, design the profile gradeline to provide a balance of earthwork. However, this should not be achieved at the expense of smooth grade lines, aesthetics, or sight distance requirements at vertical curves, or where there is excessive land acquisition costs. Ultimately, a project-by-project assessment will determine whether a project will be borrow, waste, or balanced.

Consider the following when determining earthwork balance:

1. Basic Approach. The best approach to laying grade and balancing earthwork is to provide a significant length of roadway in embankment and to limit the number and amount of excavation areas. As practical, avoid long lengths of roadway in excavation and several short balance distances. Use topographic mapping to layout profile gradelines.
2. Urban/Rural. Earthwork balance is typically a practical objective only in rural areas. In urban areas, other project objectives (e.g., limiting right-of-way impacts) typically have a higher priority than balancing earthwork. In addition, excavated materials from urban projects are often unsuitable for embankments (e.g., near gas stations).

3. Borrow Sites. The availability and quality of borrow sites in the vicinity of the project will impact the desirability of balancing the earthwork. Triangular shaped remainders or landlocked right-of-way parcels usually provide potential locations for borrow sites.
4. Earthwork Computations. On large projects (e.g., freeways or expressways, bypasses, horizontal curve relocations) preliminary earthwork is calculated during Phase I using topographic mapping and is later refined during the preparation of construction plans. Section 64-2 discusses the proper methods to compute and record the project earthwork quantities.

### 33-6.04(h) Bridges

Carefully coordinate the design of the profile gradeline with any bridges within the project limits. The following will apply:

1. Vertical Clearances. The criteria in Chapters 44 through 50 must be met. When laying the preliminary grade line, an important element in determining the available vertical clearance is the assumed structure depth. This will be based on the structure type, span lengths, and depth/span ratio. For preliminary designs, see the *Bridge Manual* and Chapter 39. For final design, the designer must coordinate with the Bureau of Bridges and Structures to determine the roadway and bridge gradelines. This is typically accomplished with a Type, Size, and Location (TS&L) Drawing.
2. Bridges Over Waterways. Where a proposed facility will cross a body of water, the bridge elevation must be consistent with the necessary waterway opening to meet the Department's hydraulic requirements. The elevation of the bottom of the superstructure must meet the requirements of Chapter 39. The designer must coordinate with the Hydraulics Unit in the Bureau of Bridges and Structures to determine the appropriate bridge elevation. In addition, where a bridge over a waterway is located in a sag curve, desirably, locate the low point of the sag vertical curve off the bridge deck, and provide at least a 0.5% grade on the bridge deck.
3. Railroad Bridges. Any proposed highway over a railroad must meet the applicable criteria (e.g., vertical clearances, structure type and depth). For rural freeways and expressways over railroads, the approach grades are usually set at 3%. Use the K-value, as discussed in Section 33-4.01, for the crest vertical curve. Use a long sag vertical curve at the bottom of each 3% grade to provide a smooth and aesthetically pleasing profile. In addition, if the alignment of the highway over the railroad will have a horizontal curve near the crest of the vertical curve, do not place the P.C. of the horizontal curve any closer than 400 ft (120 m) from the back of the bridge abutment. This guideline will ensure proper sight distance to the beginning of the horizontal curve.
4. Highway Under Bridge. Where practical, the low point of a roadway sag vertical curve should not be within the shadow of the bridge. This will help minimize ice accumulations, and it will reduce the ponding of water beneath the bridge. To achieve

these objectives, the low point of a roadway sag should be approximately 100 ft (30 m) or more from the side of the bridge.

5. High Embankments. Consider the impact that high embankments will have on bridges and culverts. High embankments will increase the span length thus increasing structure costs and increase the length and type of culvert to carry the overburden.
6. Bridges Over Another Highway. Typically, the overpassing bridge will be located on a crest vertical curve. For bridges on crossroads through an interchange, use the desirable K-value for the crest vertical curve. For other bridges, the use of minimum K-values is acceptable.

#### **33-6.04(i) At-Grade Railroad Crossings**

The profile gradeline should be essentially level across the railroad tracks and extend level for a minimum distance of 2 ft (600 mm) on either side of the outermost rails. After this point, the grade should not exceed  $\pm 1\%$  for a distance of at least 26 ft (8 m) or to the railroad right-of-way line. Profile gradelines outside of the railroad right-of-way but within the jurisdiction of the Illinois Commerce Commission should be as flat as practical and should not exceed 5%. Where superelevated tracks make strict compliance with this criteria impractical, construct the grade of the approaches to provide the best (smoothest) profile practical.

#### **33-6.04(j) Distance Between Vertical Curves**

A desirable objective on rural facilities is to provide at least 1500 ft (500 m) between two successive VPI's. This objective only applies to projects which have a considerable length and where implementation is judged to be practical.

#### **33-6.04(k) Ties With Existing Highways**

A smooth transition is needed between the proposed profile gradeline of the project and the existing gradeline of an adjacent highway section. Consider existing gradelines for a sufficient distance beyond the beginning and end of a project to ensure adequate sight distances. Connections should be made that are compatible with the design speed of the new project and that can be used if the adjoining road section is reconstructed. For example, do not transition a four-lane highway section to two lanes just beyond a crest vertical curve but, instead, locate the transition away from the high point of the crest vertical curve.

**33-7 REFERENCES**

1. *A Policy on Geometric Design of Highways and Streets*, AASHTO, 2004.
2. *Highway Capacity Manual 2010*, Transportation Research Board, 2010.
3. *Metric Analysis Reference Guide, Supplement to 1997 Update of Special Report 209 Highway Capacity Manual*, TRB, 1997.
4. *Methods for Predicting Truck Speed Loss on Grades*, Federal Highway Administration, Report No. FHWA/RD-86/059, October 1986.
5. *New Methods for Determining Requirements for Truck-Climbing Lanes*, Federal Highway Administration, Publication No. FHWA-IP-89-022, September 1989.
6. *Traffic Policies and Procedures Manual*, Bureau of Operations, IDOT.
7. Chapter Four "Roads," *National Forest Landscape Management*, Volume 2, Forest Service, US Department of Agriculture, March 1977.
8. *A Guide for Transportation Landscape and Environmental Design*, AASHTO, June 1991.
9. "Coordination of Horizontal and Vertical Alignment With Regard to Highway Aesthetics," *Transportation Research Record 1445*, TRB, 1994.
10. *Design Guidelines for the Control of Blowing and Drifting Snow*, Strategic Highway Research Program, National Research Council, 1994.

