

* Less than 12 (300) formed roundout to be used.

CAST IN PLACE DETAIL

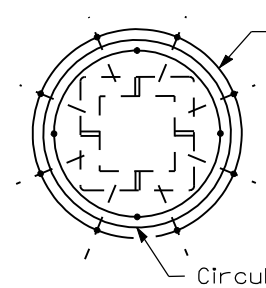

Circular form

All dimensions same for the majority of circular frame & grates. For larger structures increase hoop bar and circular form diameter by 12 (300) each and add two additional equally spaced tie bars.

ROUNDOUT FOR SQUARE FRAME & GRATE AND MANHOLES

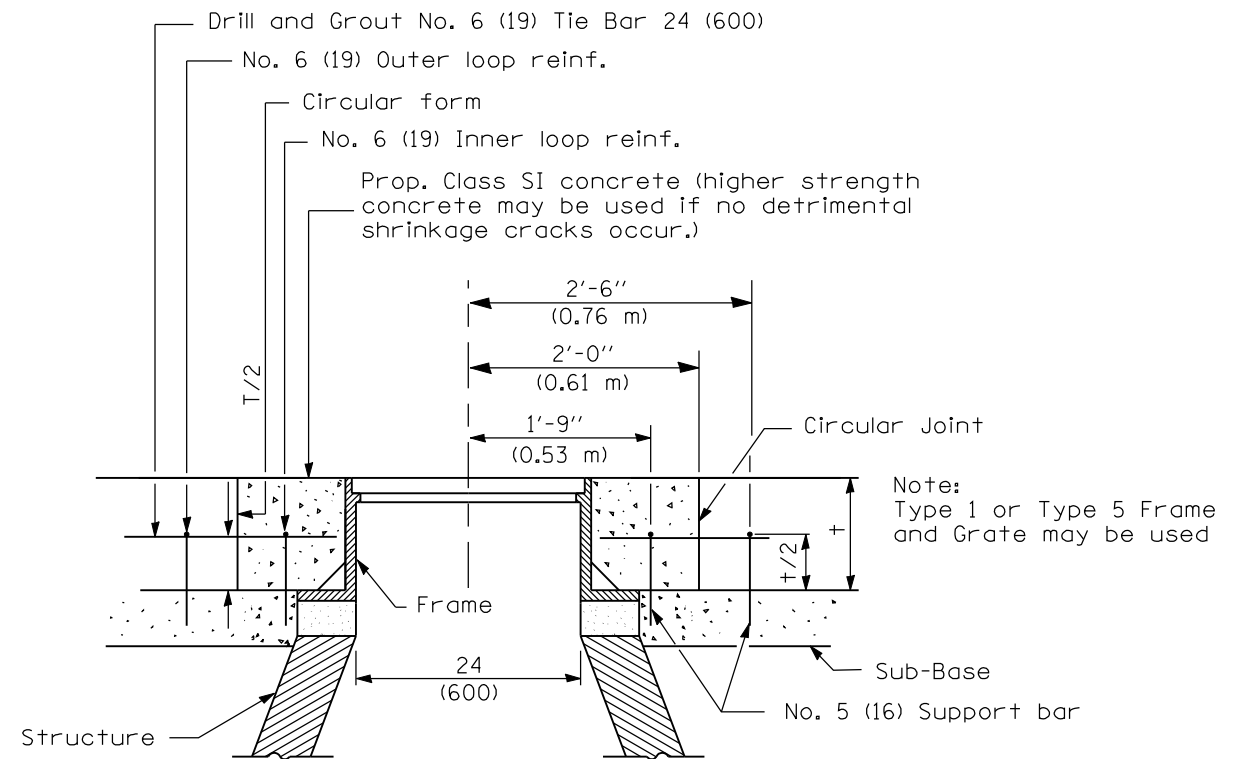
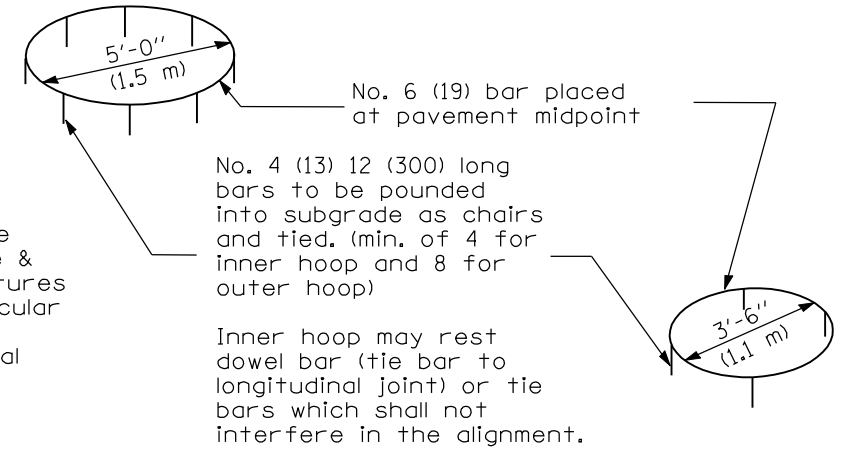

DETAIL OF REINFORCEMENT FOR PAVEMENT ROUNDOUT