

CAST FRAME

Ø 15 (5/8) dia. hole and 15x120 (5/8 x 4 3/4) slotted hole for galvanized M12 (1/2) bolt, nut and washer.

Curb box adjustable from 135 (5 1/4) to 225 (9)

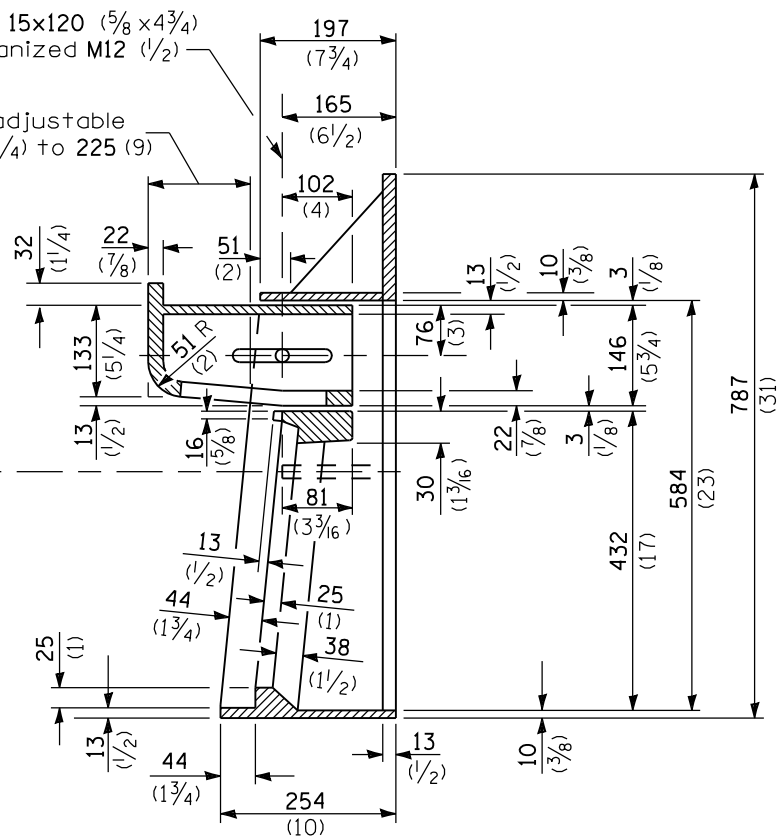

SECTION B-B

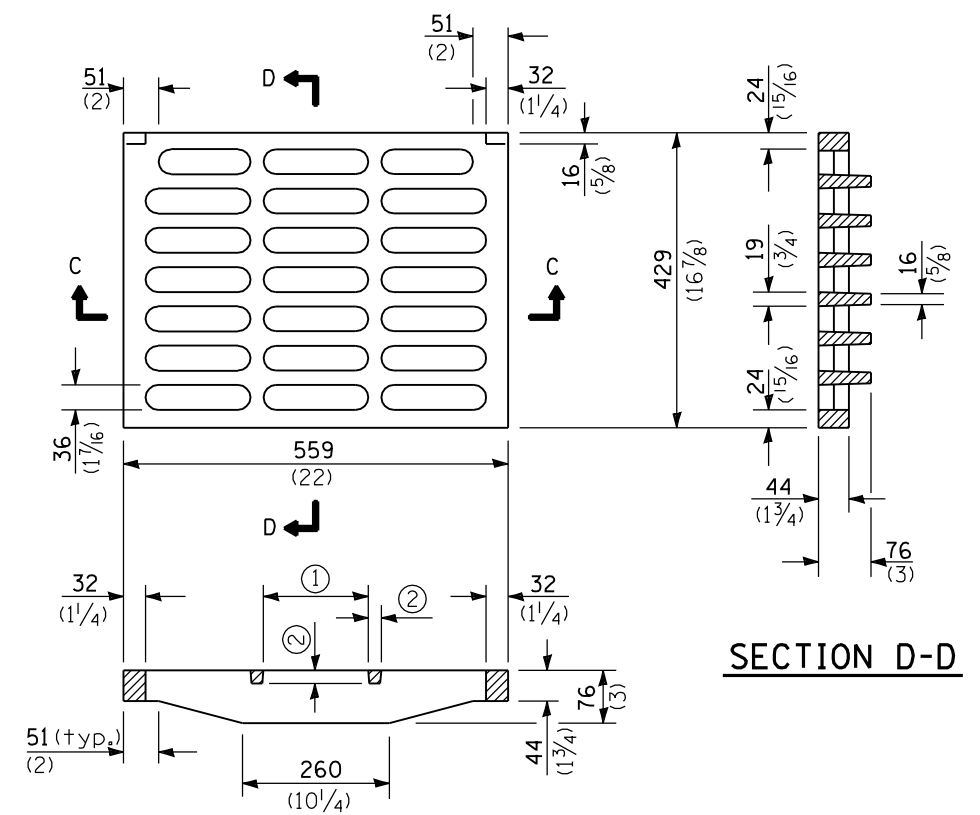

SECTION C-C

- ① = 152 (6) typ.
- ② = 19 (3/4) typ.

SECTION D-D

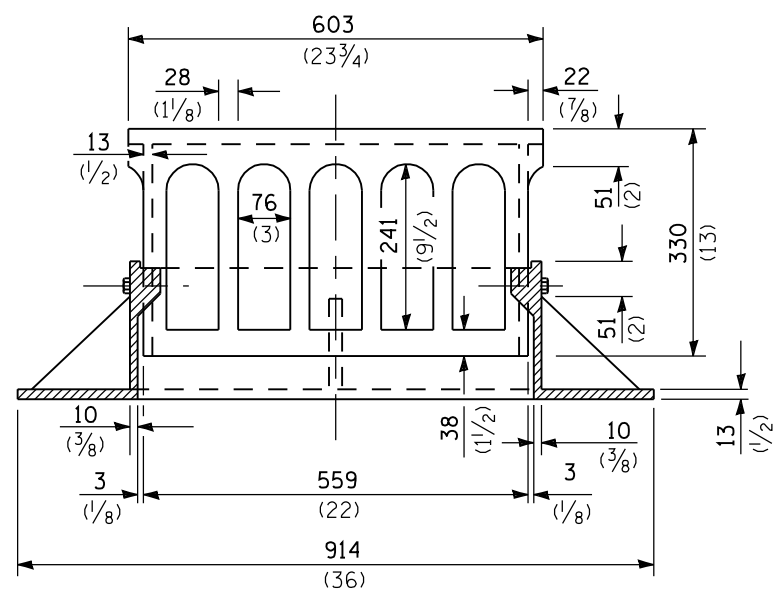

SECTION A-A

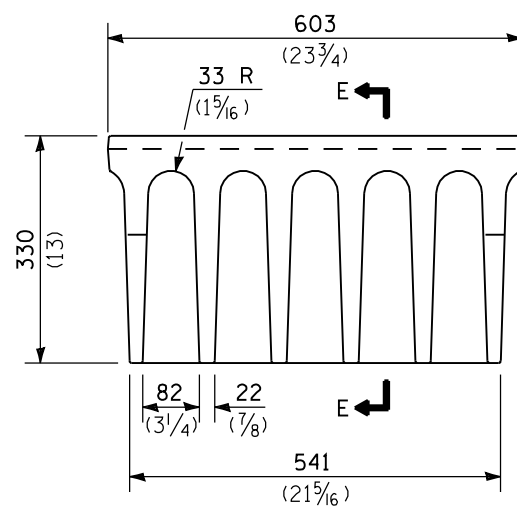

ALTERNATE CURB BOX

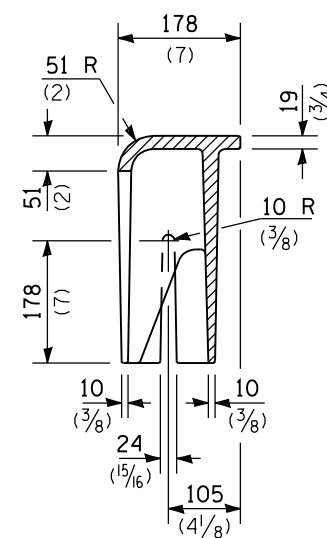

SECTION E-E

CAST GRATE

All dimensions are in millimeters (inches) unless otherwise shown.

Illinois Department of Transportation
 PASSED January 1, 2008
 ENGINEER OF POLICY AND PROCEDURES
 APPROVED January 1, 2008
 ENGINEER OF DESIGN AND ENVIRONMENT

DATE	REVISIONS
1-1-08	Added alternate curb box.
1-1-04	Revised frame and removed weights.

**FRAME AND GRATE
TYPE 3**

STANDARD 604006-03