

END ANCHOR ARRANGEMENT

TYPICAL FOOTINGS FOR POST AND ANCHOR WHEN IMPERVIOUS MATERIAL IS ENCOUNTERED

INTERMEDIATE ANCHOR ARRANGEMENT

DEAD END ANCHOR ARRANGEMENT

NOTES

V + W shall not exceed 990 (39). When V is 0 to 380 (15), W = 610 (24), and posts shall be shortened as required. When V exceeds 380 (15), W shall be shortened correspondingly.

T = 380 (15) when U is 840 (33) or less. When U exceeds 840 (33) the impervious material shall be removed and the standard anchor shall be used.

Timber blocks shall be nailed to each wood post on the concave side of curve for curves having a radius of less than 180 m (600').

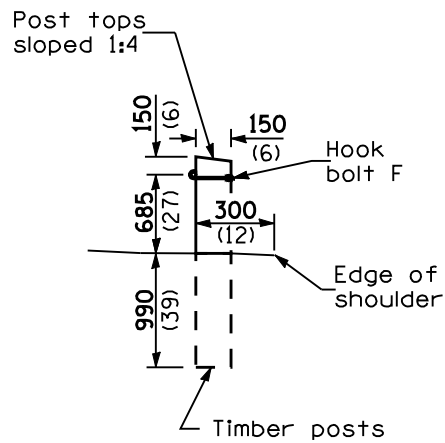

VIEW X-X

Typical Wood Materials	
Item	Size
Post	100x150x1.83 m (4x6x6'0")
Block	50x300x450 (2x12x18)
Rail	50x150 (2x6)
Spacer	50x150x150 (2x6x6)

GENERAL NOTES

The Engineer will determine the stability of the impervious material for anchoring.

All timber shall be either S4S or rough sawn and be treated according to the applicable specification.

All slope ratios are expressed as units of vertical displacement to units of horizontal displacement (V:H).

All dimensions are in millimeters (inches) unless otherwise shown.

DATE	REVISIONS
1-1-05	Corrected note on Post Anchor detail on sheet 3 of 3.
1-1-97	Renum. Standard 2170-8. Deleted DN Symbol.

CABLE ROAD GUARD SINGLE STRAND

(Sheet 1 of 3)

STANDARD 636001-01

Illinois Department of Transportation

PASSED January 1, 2005
Michael Brand
 ENGINEER OF POLICY AND PROCEDURES

APPROVED January 1, 2005
Michael J. Howe
 ENGINEER OF DESIGN AND ENVIRONMENT

ISSUED 16-1-1-17

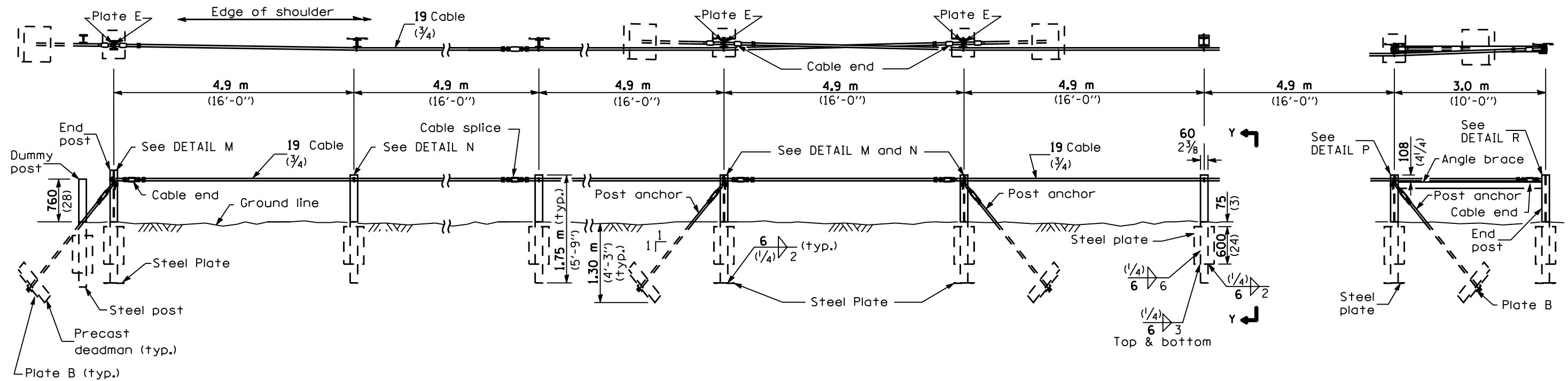

END ANCHOR ARRANGEMENT

INTERMEDIATE ANCHOR ARRANGEMENT

DEAD END ANCHOR ARRANGEMENT

TYPICAL STEEL MATERIALS	
Item	Size
Post	S75x8.5x1.75 m (S3x5.7x5'-9")
Bottom Plate	6x200x200 (1/4x8x8)
Side Plate	6x200x600 (1/4x8x24)
Brace	L 102x76x9.5 (L 4x3x3/8)

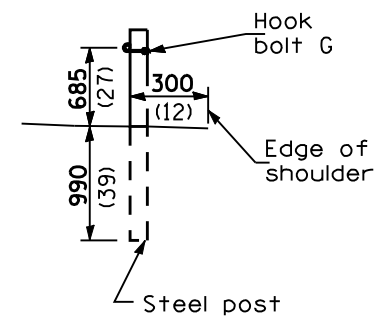

VIEW Y-Y

All dimensions are in millimeters (inches) unless otherwise shown.

CABLE ROAD GUARD SINGLE STRAND

(Sheet 2 of 3)

STANDARD 636001-01

Illinois Department of Transportation

PASSED January 1, 2005
Michael Brand
 ENGINEER OF POLICY AND PROCEDURES

APPROVED January 1, 2005
Michael L. Home
 ENGINEER OF DESIGN AND ENVIRONMENT

ISSUED 1-1-97

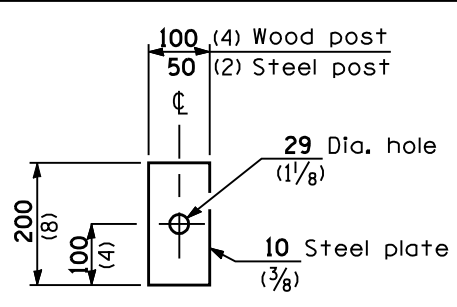

PLATE C

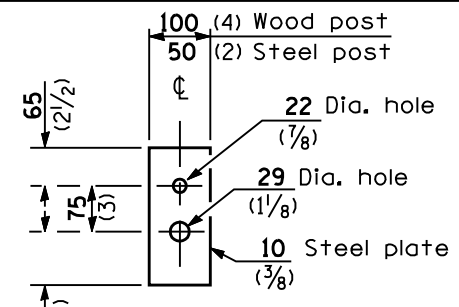
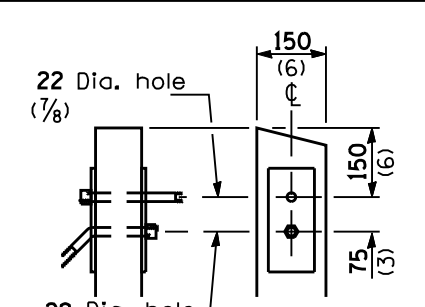
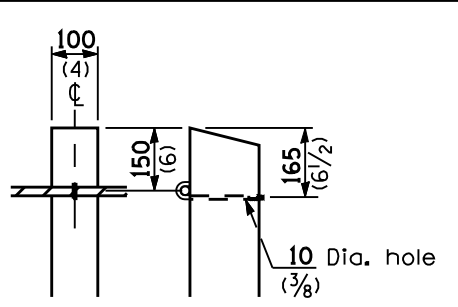

PLATE E



DETAIL H



DETAIL J

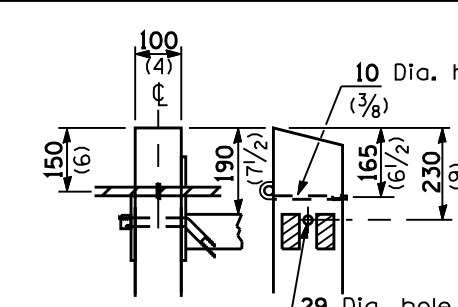

DETAIL K

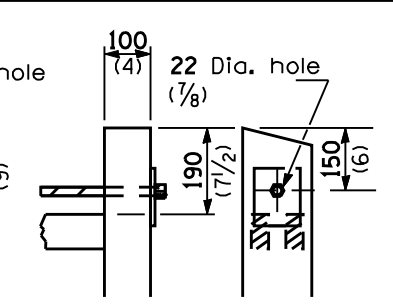

DETAIL L

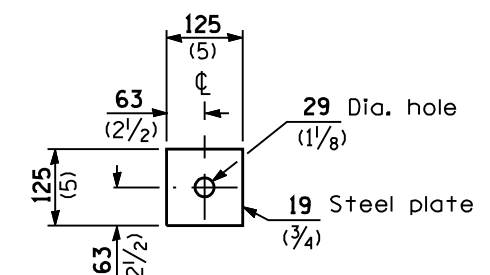

PLATE B

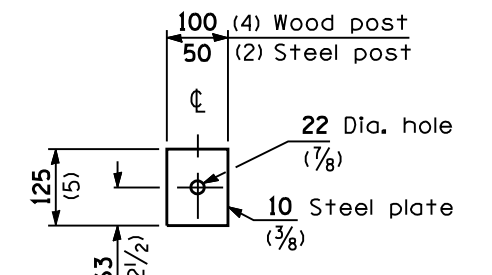
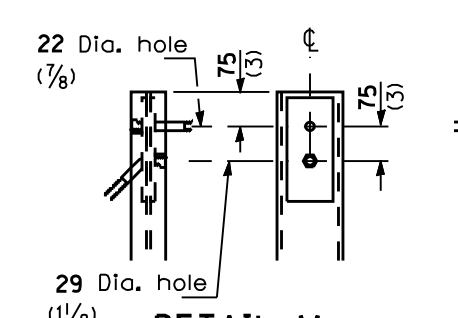
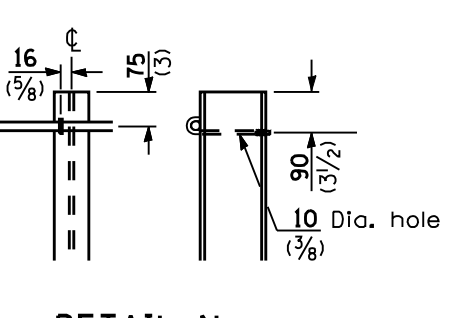

PLATE D



DETAIL M



DETAIL N

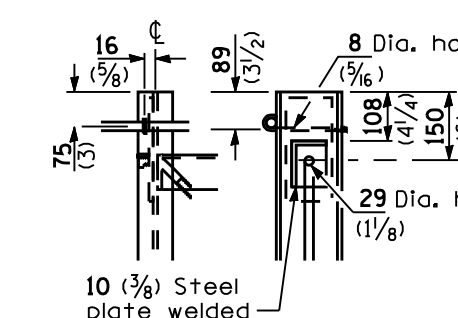

DETAIL P

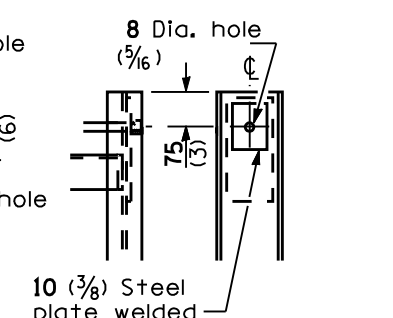

DETAIL R

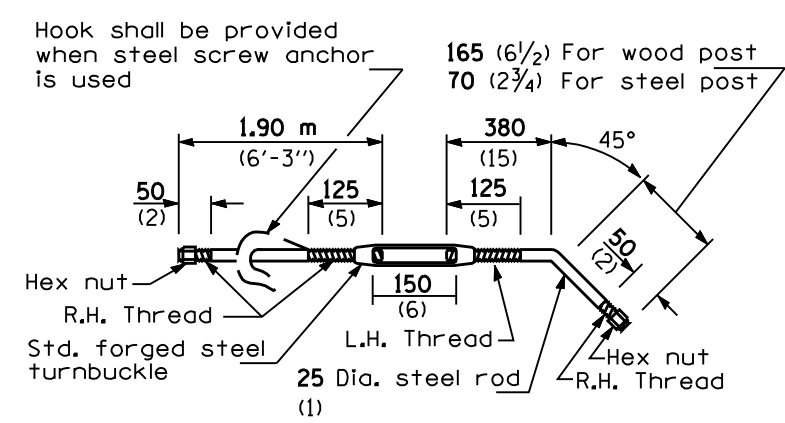

POST ANCHOR

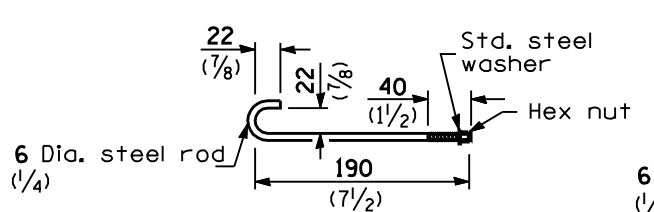

HOOK BOLT F

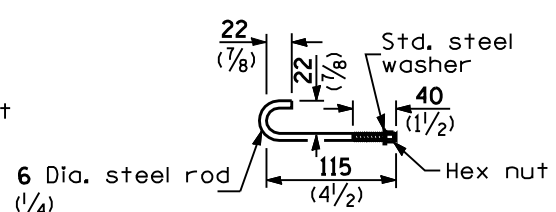

HOOK BOLT G

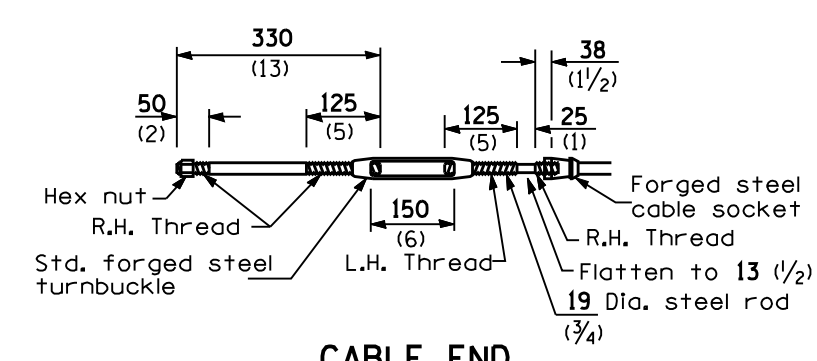

CABLE END

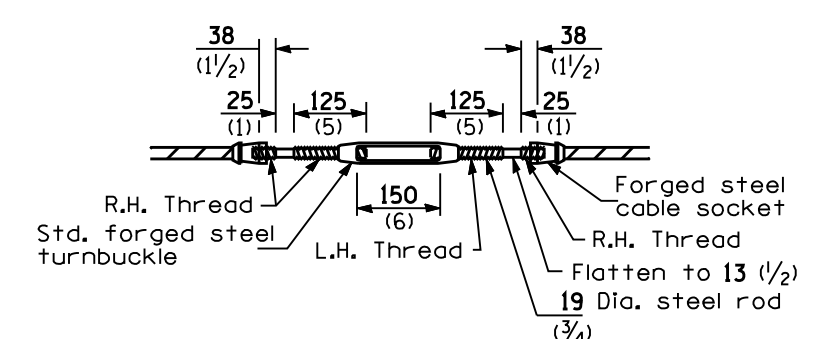

CABLE SPLICE

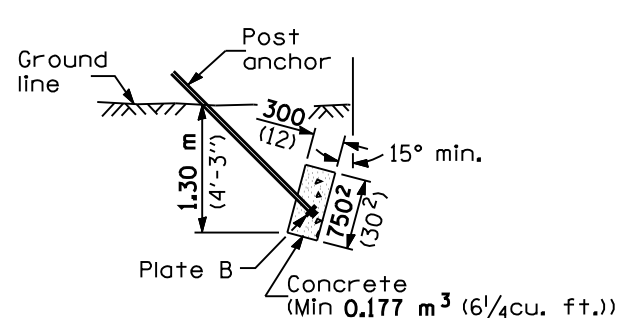

CAST IN PLACE DEADMAN

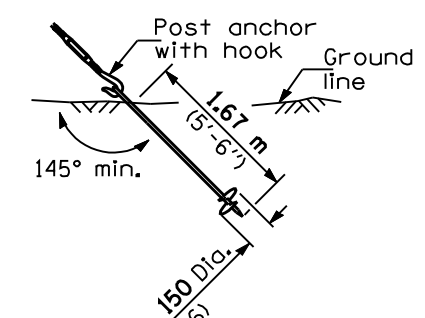

STEEL SCREW

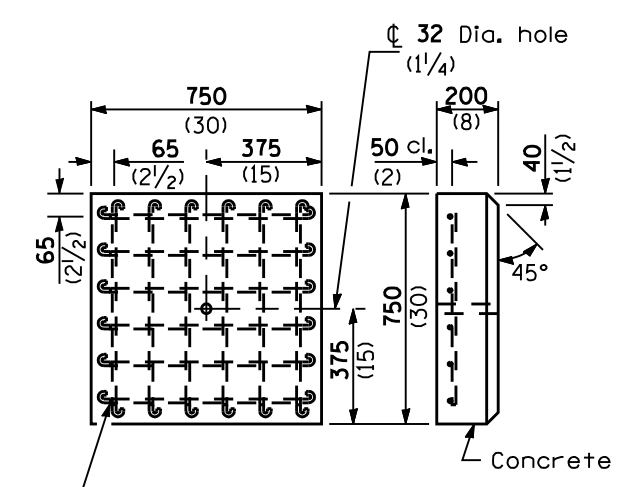

PRECAST DEADMAN

No. 15 (No. 4) Bars 685 (27) long, at 127 (5) cts. each way

All dimensions are in millimeters (inches) unless otherwise shown.

**CABLE ROAD GUARD
SINGLE STRAND**
(Sheet 3 of 3)

STANDARD 636001-01

Illinois Department of Transportation

PASSED January 1, 2005
Michael Brand
ENGINEER OF POLICY AND PROCEDURES

APPROVED January 1, 2005
Michael J. Hine
ENGINEER OF DESIGN AND ENVIRONMENT

ISSUED 1-1-97
15-1-97