

**HMA SHOULDER STRIP AND
AGGREGATE WEDGE WITH WIDENING**

(Cross-section A)

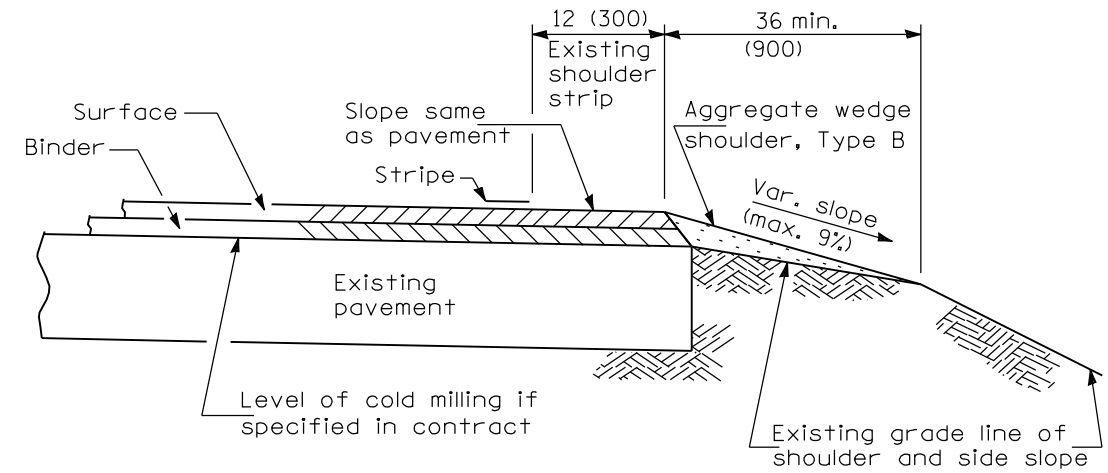

**COLD MILLING AND/OR RESURFACING OF
EXISTING PAVEMENT WITH SHOULDER STRIPS**

(Cross-section C)

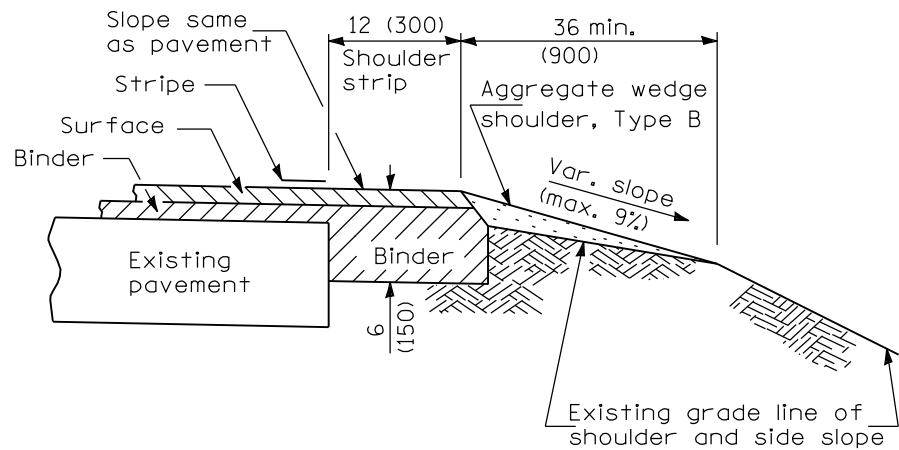

**HMA SHOULDER STRIP AND
AGGREGATE WEDGE WITH RESURFACING**

(Cross-section B)

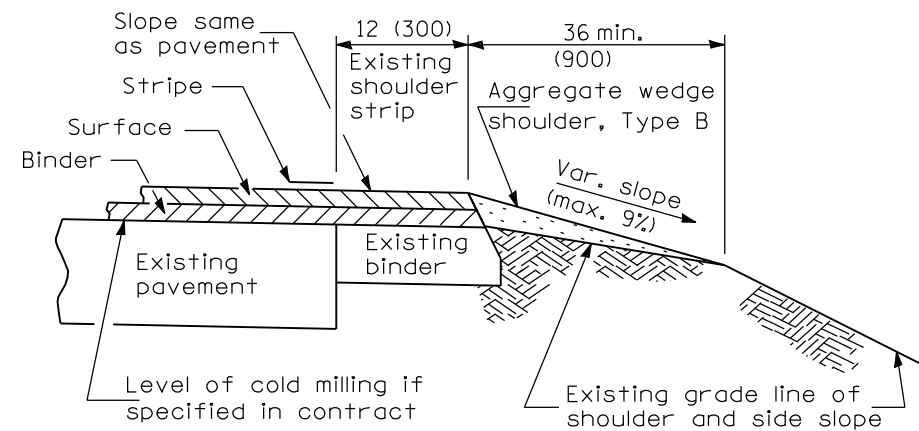

**COLD MILLING AND/OR RESURFACING OF
EXISTING PAVEMENT WITH SHOULDER STRIPS**

(Cross-section D)

All dimensions are in inches (millimeters) unless otherwise shown.

Illinois Department of Transportation

PASSED January 1, 2008
Scott Smith
 ENGINEER OF POLICY AND PROCEDURES

APPROVED January 1, 2008
Ken E. Han
 ENGINEER OF DESIGN AND ENVIRONMENT

ISSUED 1-1-97

DATE	REVISIONS
1-1-08	Switched units to English (metric).
1-1-07	Switched to Hot-Mix Asphalt (HMA) terminology.

**HMA SHLD. STRIPS/SHLDS. WITH
RESURFACING OR WIDENING
AND RESURFACING PROJECTS**
 (Sheet 1 of 2)

STANDARD 482011-03

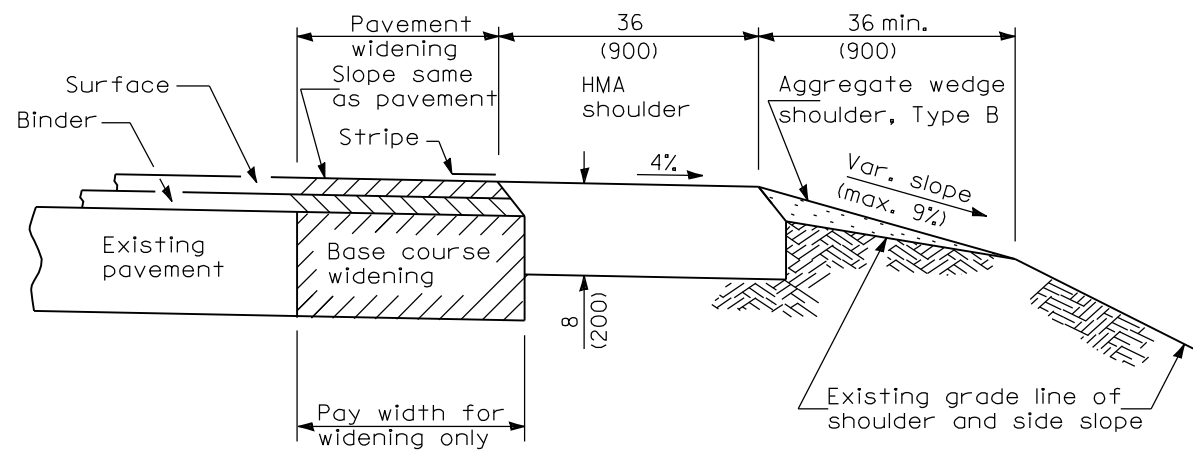

**HMA SHOULDER AND AGGREGATE
WEDGE WITH WIDENING**
(Cross-section E)

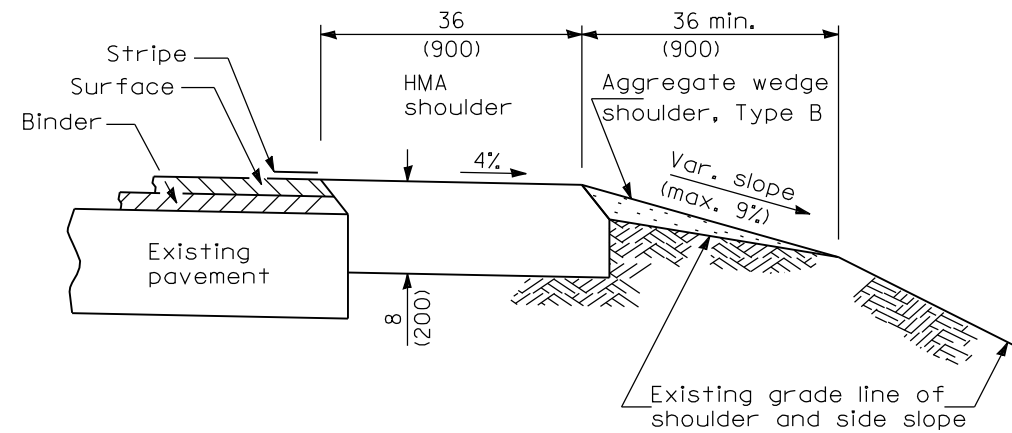

**HMA SHOULDER AND AGGREGATE
WEDGE WITH RESURFACING**
(Cross-section G)

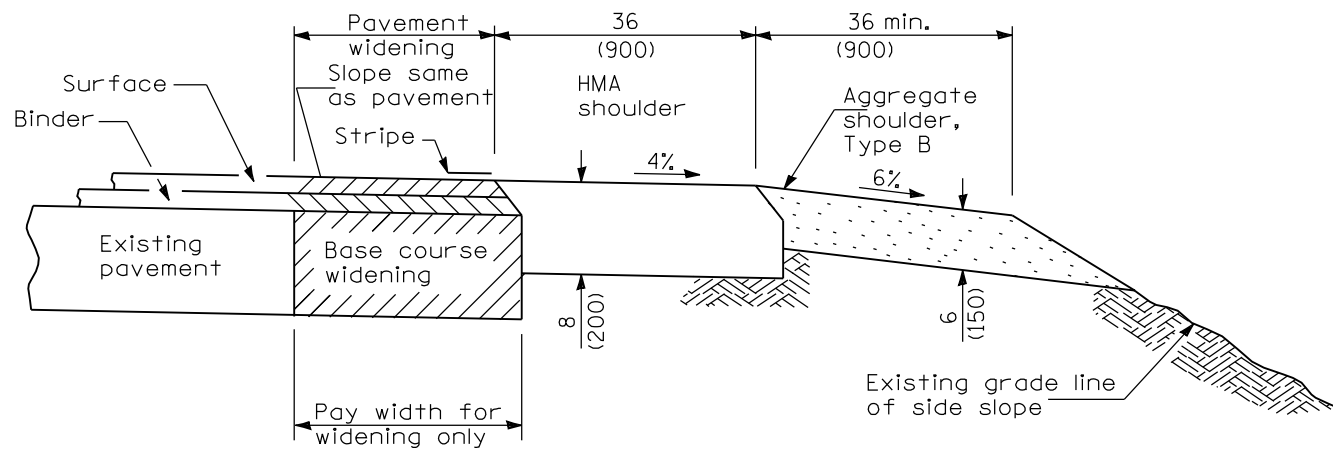

**HMA AND AGGREGATE
SHOULDERS WITH WIDENING**
(Cross-section F)

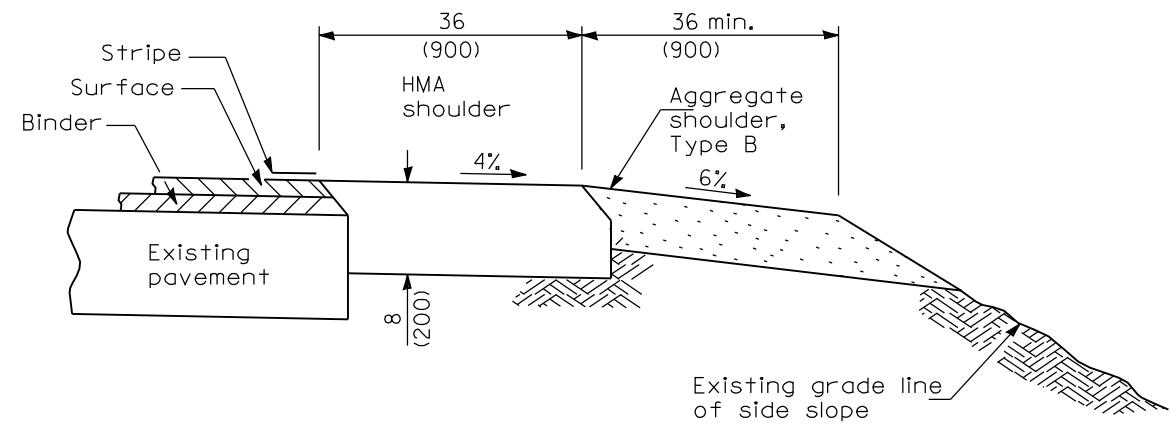

**HMA AND AGGREGATE SHOULDERS
WITH RESURFACING**
(Cross-section H)

Illinois Department of Transportation
 PASSED January 1, 2008
 ENGINEER OF POLICY AND PROCEDURES
 APPROVED January 1, 2008
 ENGINEER OF DESIGN AND ENVIRONMENT

ISSUED 1-1-97

**HMA SHLD. STRIPS/SHLDS. WITH
RESURFACING OR WIDENING
AND RESURFACING PROJECTS**
(Sheet 2 of 2)

STANDARD 482011-03