

**SHOULDER WIDENING TRANSITION
FOR TANGENT TERMINAL**

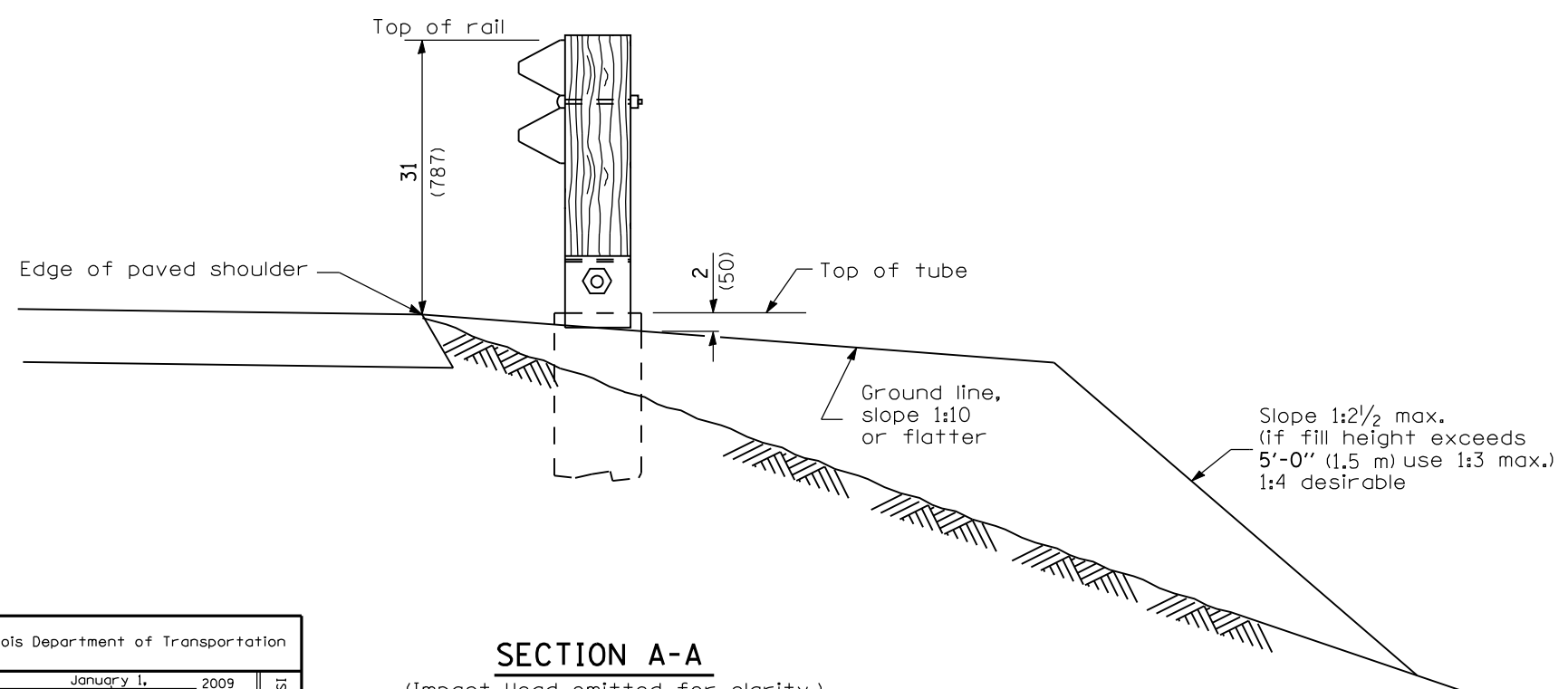

SECTION A-A
(Impact Head omitted for clarity.)

GENERAL NOTES

50:1 Taper required so the guardrail head will not encroach on the shoulder.

All slope ratios are expressed as units of vertical displacement to units of horizontal displacement (V:H).

All dimensions are in inches (millimeters) unless otherwise shown.

Illinois Department of Transportation

PASSED January 1, 2009
Spattesch
ENGINEER OF POLICY AND PROCEDURES

APPROVED January 1, 2009
Ken E. Han
ENGINEER OF DESIGN AND ENVIRONMENT

ISSUED 1-1-09

DATE	REVISIONS
1-1-09	Switched units to English (metric).
1-1-07	Changes adopted to implement the Midwest Guardrail System.

**SHOULDER WIDENING FOR
TYPE 1 (SPECIAL)
GUARDRAIL TERMINALS**
(Sheet 1 of 2)

STANDARD 630301-05

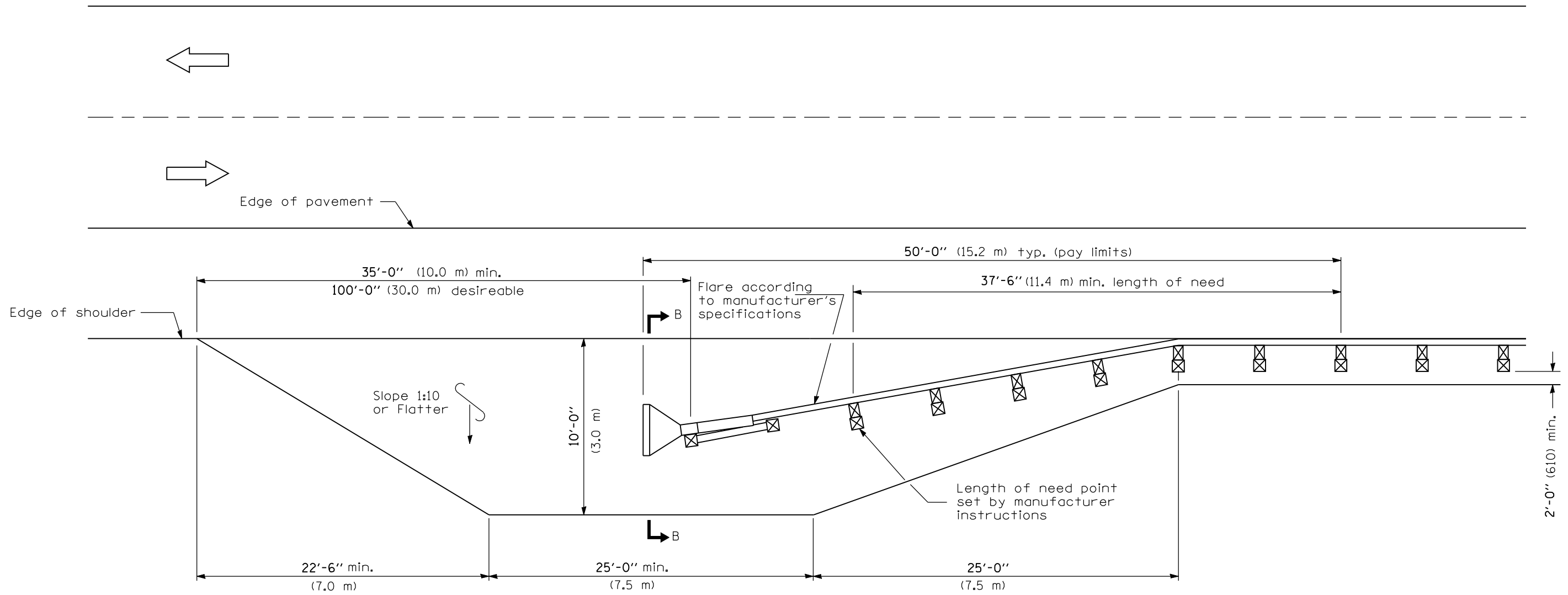

**SHOULDER WIDENING TRANSITION
FOR FLARED TERMINAL**

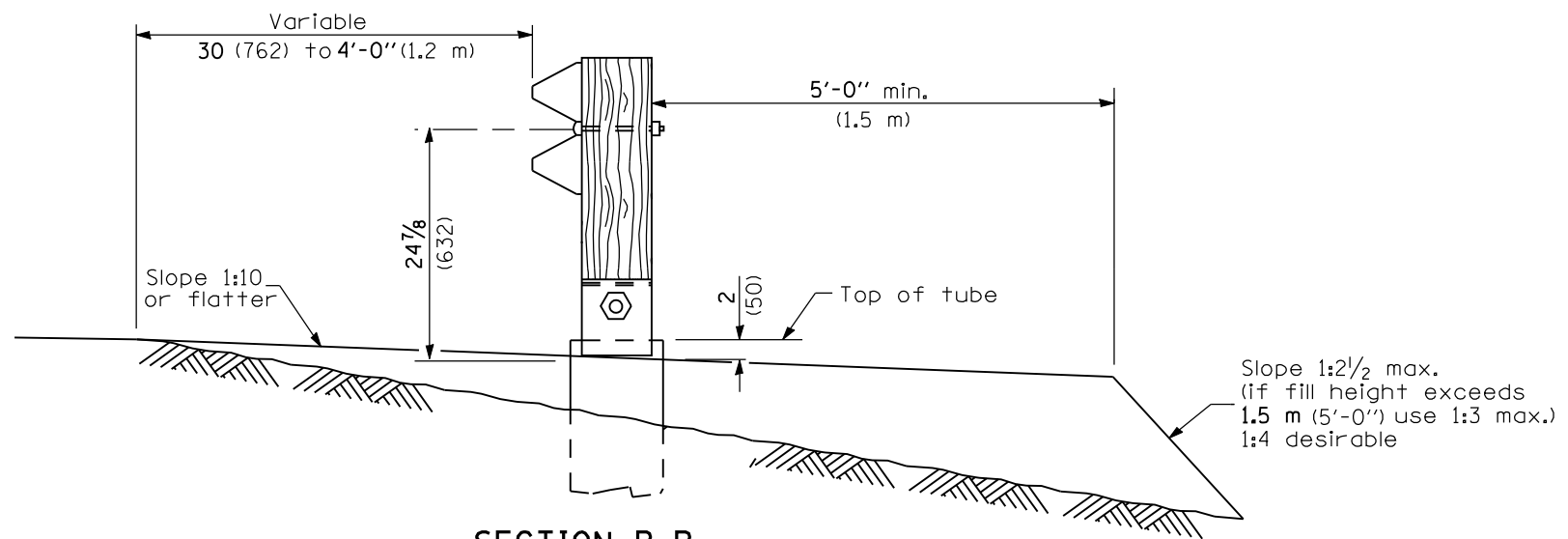

SECTION B-B

(Impact Head omitted for clarity.)

Illinois Department of Transportation
 PASSED January 1, 2009
 ENGINEER OF POLICY AND PROCEDURES
 APPROVED January 1, 2009
 ENGINEER OF DESIGN AND ENVIRONMENT

ISSUED 1-1-00

**SHOULDER WIDENING FOR
TYPE 1 (SPECIAL)
GUARDRAIL TERMINALS**
 (Sheet 2 of 2)
STANDARD 630301-05