

END ANCHOR ARRANGEMENT

TYPICAL FOOTINGS FOR POST AND ANCHOR WHEN IMPERVIOUS MATERIAL IS ENCOUNTERED

INTERMEDIATE ANCHOR ARRANGEMENT

DEAD END ANCHOR ARRANGEMENT

NOTES

V + W shall not exceed 39 (990). When V is 0 to 15 (380), W = 24 (610), and posts shall be shortened as required. When V exceeds 15 (380), W shall be shortened correspondingly.

T = 15 (380) when U is 33 (840) or less. When U exceeds 33 (840) the impervious material shall be removed and the standard anchor shall be used.

Timber blocks shall be nailed to each wood post on the concave side of curve for curves having a radius of less than 600' (180 m).

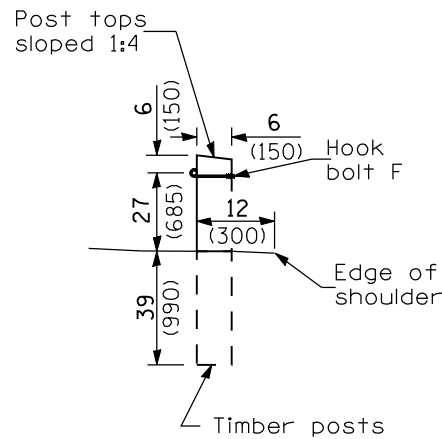

VIEW X-X

Typical Wood Materials	
Item	Size
Post	4x4x6'-0" (100x150x1.83 m)
Block	2x12x18 (50x300x450)
Rail	2x6 (50x150)
Spacer	2x6x6 (50x150x150)

GENERAL NOTES

The Engineer will determine the stability of the impervious material for anchoring.

All slope ratios are expressed as units of vertical displacement to units of horizontal displacement (V:H).

All dimensions are in inches (millimeters) unless otherwise shown.

DATE	REVISIONS
1-1-09	Switched units to Eng. (met.). omitted precast deadman and gen. note.
1-1-05	Corrected note on Post Anchor detail on sheet 3 of 3.

CABLE ROAD GUARD SINGLE STRAND

(Sheet 1 of 3)

STANDARD 636001-02

Illinois Department of Transportation

PASSED January 1, 2009

ENGINEER OF POLICY AND PROCEDURES

APPROVED January 1, 2009

ENGINEER OF DESIGN AND ENVIRONMENT

ISSUED 1-1-07

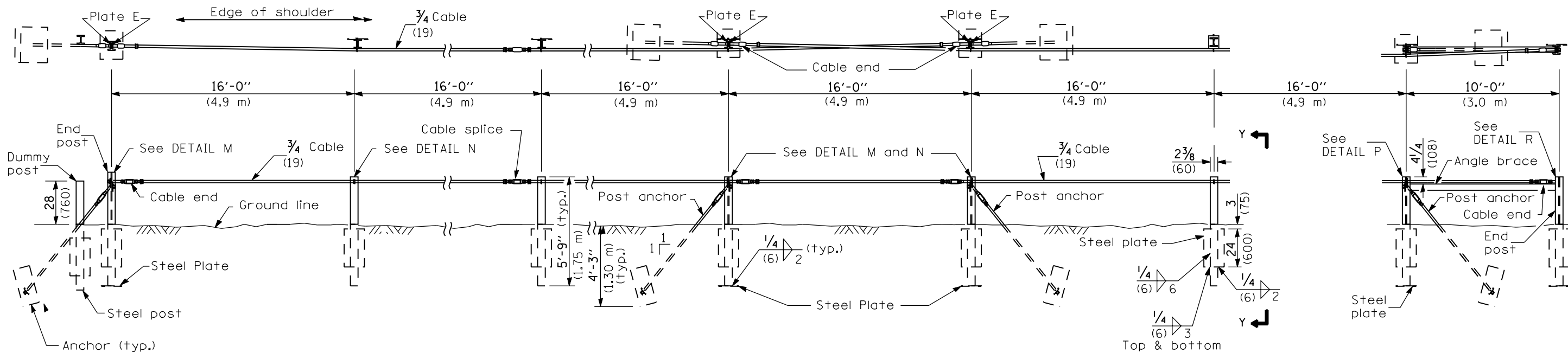

END ANCHOR ARRANGEMENT

INTERMEDIATE ANCHOR ARRANGEMENT

DEAD END ANCHOR ARRANGEMENT

TYPICAL STEEL MATERIALS	
Item	Size
Post	S3x5.7x5'-9" (S75x8.5x1.75 m)
Bottom Plate	1/4x8x8 (6x200x200)
Side Plate	1/4x8x24 (6x200x600)
Brace	L 4x3x3/8 (L 102x76x9.5)

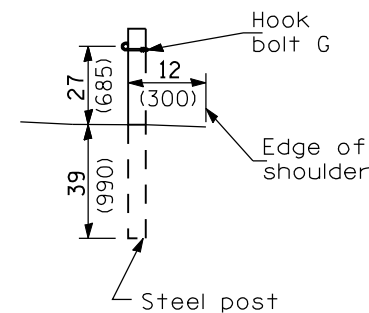

VIEW Y-Y

Illinois Department of Transportation
 PASSED January 1, 2009
 ENGINEER OF POLICY AND PROCEDURES
 APPROVED January 1, 2009
 ENGINEER OF DESIGN AND ENVIRONMENT

ISSUED 1-1-97

CABLE ROAD GUARD SINGLE STRAND

(Sheet 2 of 3)

STANDARD 636001-02

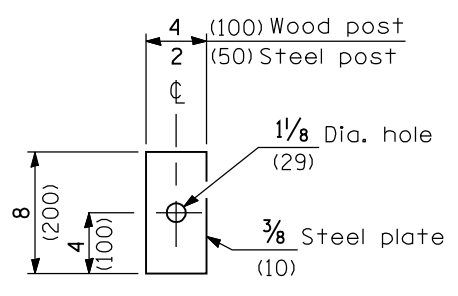

PLATE C

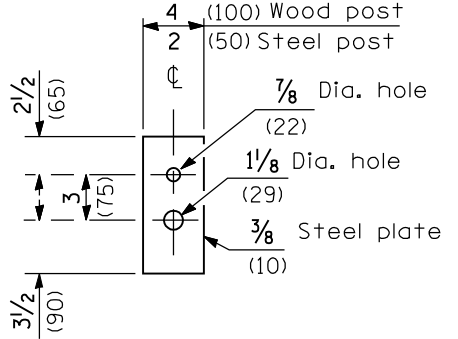
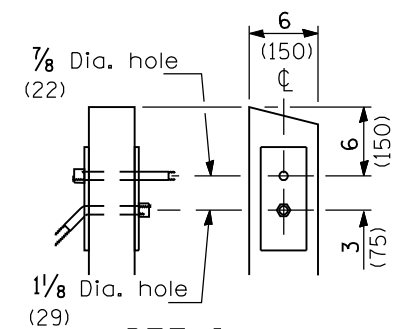
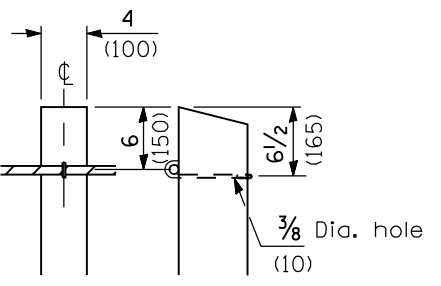

PLATE E



DETAIL H



DETAIL J

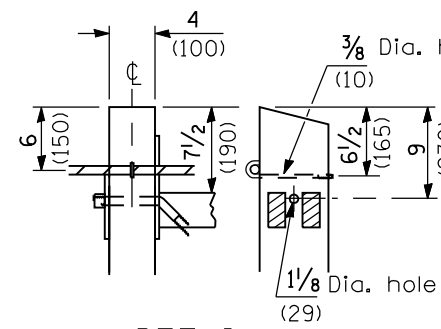

DETAIL K

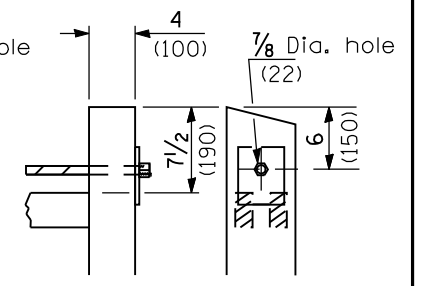

DETAIL L

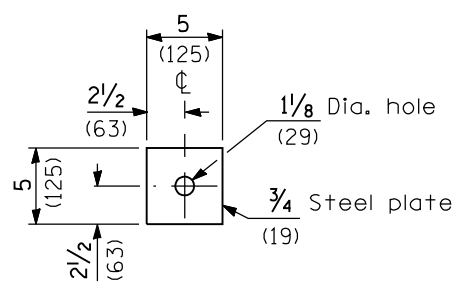

PLATE B

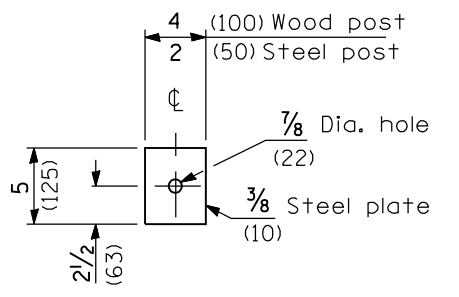
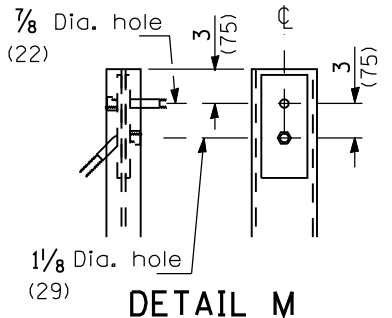
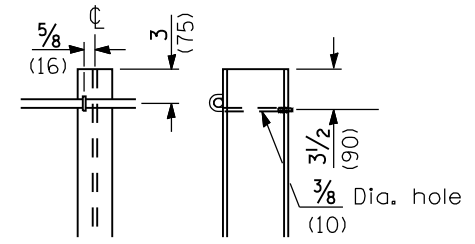

PLATE D



DETAIL M



DETAIL N

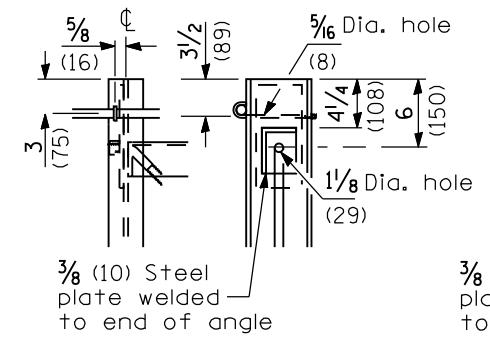

DETAIL P

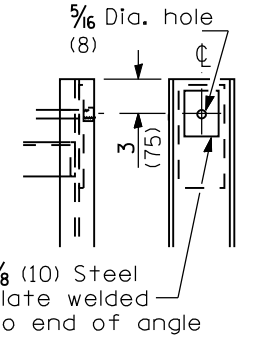

DETAIL R

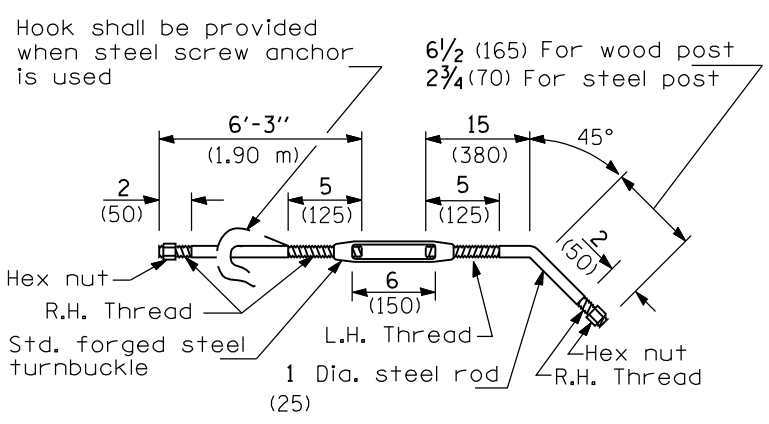

POST ANCHOR

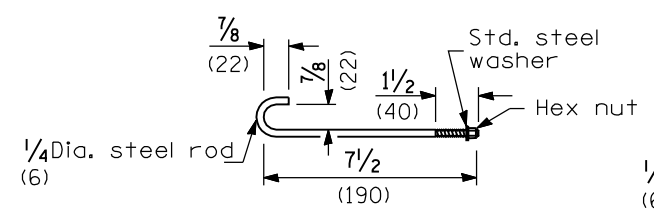

HOOK BOLT F

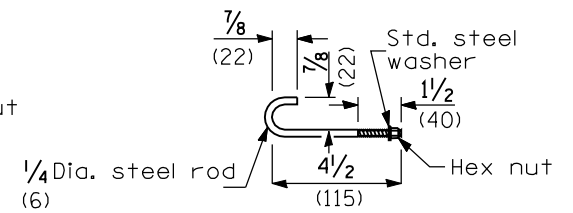

HOOK BOLT G

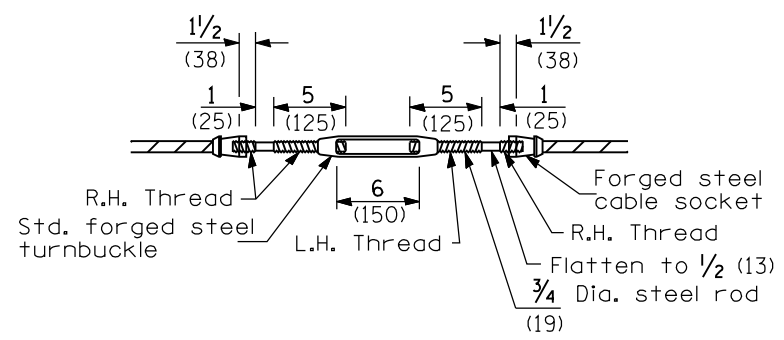

CABLE SPLICE

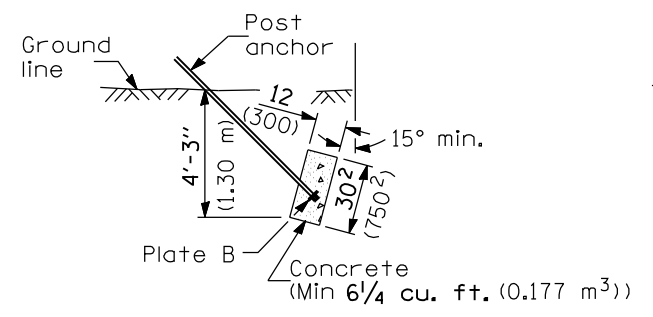

CAST IN PLACE DEADMAN

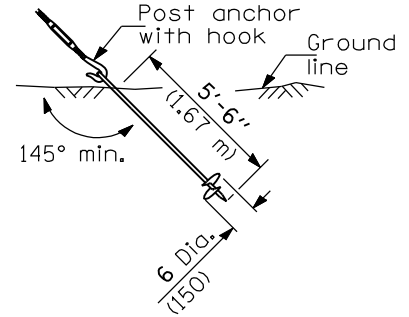

STEEL SCREW

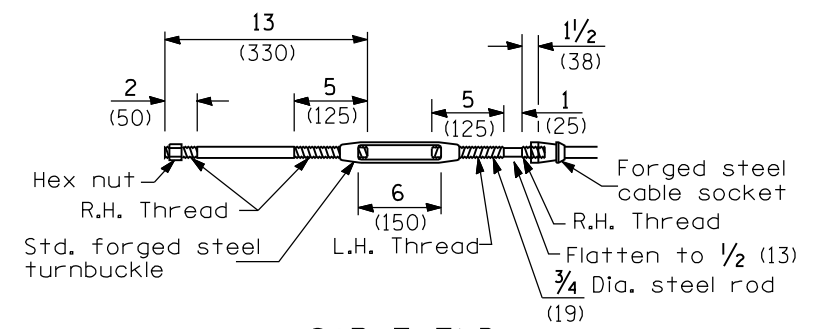

CABLE END

ALTERNATE - ANCHORS

Illinois Department of Transportation
 PASSED January 1, 2009
 ENGINEER OF POLICY AND PROCEDURES
 APPROVED January 1, 2009
 ENGINEER OF DESIGN AND ENVIRONMENT

**CABLE ROAD GUARD
 SINGLE STRAND**
 (Sheet 3 of 3)
STANDARD 636001-02