

**GROUND MOUNT DETAIL**

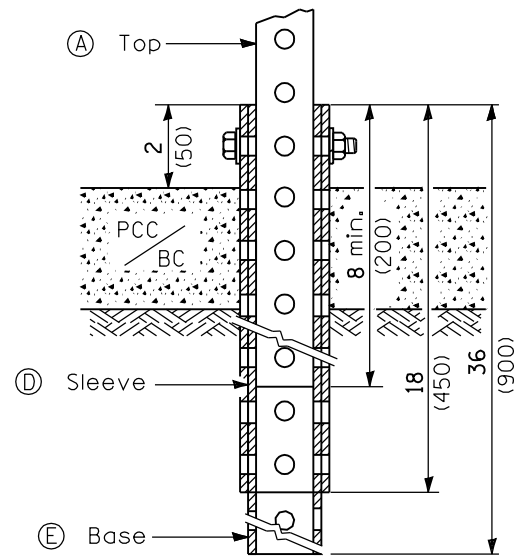

**PAVEMENT MOUNT DETAIL**

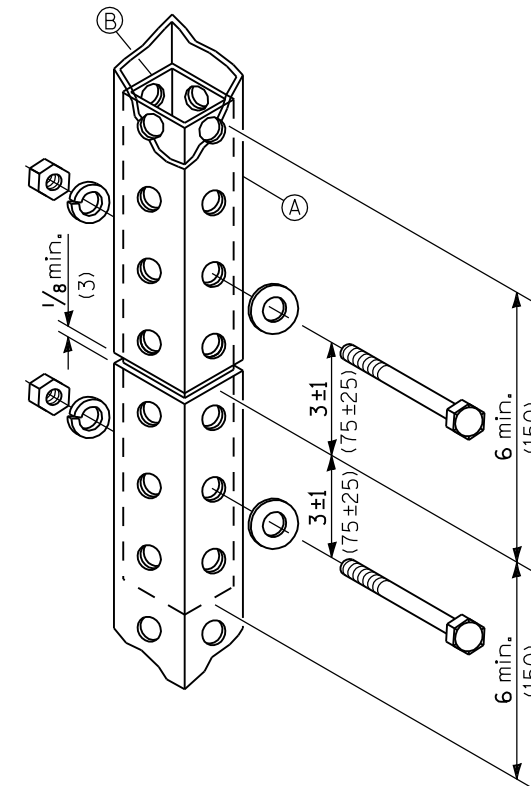

**SPLICE DETAIL**

(A)	2 x 2 x var.	(51 x 51 var.)
(B)	1 3/4 x 1 3/4 x 12	(44 x 44 x 300)
(C)	2 1/4 x 2 1/4 x 60	(57 x 57 x 1500)
(D)	2 1/2 x 2 1/2 x 18	(64 x 64 x 450)
(E)	2 1/4 x 2 1/4 x 36	(57 x 57 x 900)

**GENERAL NOTES**

All bolts 3/8" (M10) hex head zinc or cadmium plated.

All dimensions are in inches (millimeters) unless otherwise shown.

DATE	REVISIONS
1-1-09	Switched units to English (metric).
1-1-07	New Standard. Used to be part of Standard 720006.

**TELESCOPING STEEL SIGN SUPPORT**

**STANDARD 728001-01**

Illinois Department of Transportation

APPROVED January 1, 2009  
 ENGINEER OF OPERATIONS  
*[Signature]*

APPROVED January 1, 2009  
 ENGINEER OF DESIGN AND ENVIRONMENT  
*[Signature]*

ISSUED 1-1-07